



# Series B



Cone Drive Operations, Inc.  
240 East 12th Street  
Traverse City, MI 49684, USA

T +1 888 994 2663  
E [orders@conedrive.com](mailto:orders@conedrive.com)  
W [www.conedrive.com](http://www.conedrive.com)



## PRODUCTS IN THE RANGE

Serving an entire spectrum of mechanical drive applications from food, energy, mining and metal; to automotive, aerospace and marine propulsion, we are here to make a positive difference to the supply of drive solutions.



**Model HP**

Worm gear units with double-enveloping worm gearing. Available in single, double and triple reductions



**Model HP-A**

Universal metric housing featuring double-enveloping gearing & drywell feature



**Series B**

Industrial duty worm gear unit featuring Conex gearing



**DuoDrive**

Dual gears on parallel output shafts



**Extruder Drive**

Rugged duty reducer takes high screw pressure



**Stainless**

Right angle, IP 69K rated for the food processing market



**Series W**

Precision right angle servo gearboxes



**Model RG**

Moderate precision right angle servo gearboxes

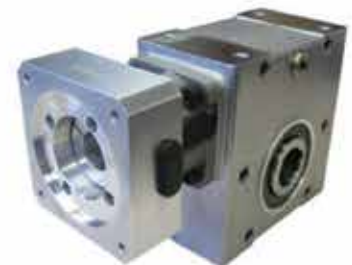

**Series S**

Value engineered right angle servo gearboxes



**Series P**

Precision planetary servo gearboxes



**Series E**

Economical planetary servo gearboxes



**Series LE**

In-line helical geared motors & reducers

**We can create custom engineered transmission solutions of any size and configuration.**

# INDUSTRIAL DUTY GEARMOTORS AND REDUCERS

The Series B right angle gearmotors and reducers provide a highly flexible and compact solution to meet the low to medium power range. With power capabilities up to 20 HP and maximum output torque capacity of 8,000 lb.in. We can provide design flexibility with lasting performance.

The Series B benefits from over 200 years of cumulative experience in the design and manufacture of high quality mechanical power transmission solutions. With features like our patented motor connection and the unique *Swift Kit* concept. Series B is the answer for your right angle drive requirements.

- **Conex™ inside, new helicoidal gear geometry provides high capacity and high efficiency.**

- **Manufactured and assembled from a family of modular kits for quick delivery.**

- **Patented motor connection eliminates fretting corrosion and provides easy motor removal.**

- **Hollow bore standard for maximum flexibility.**

- **Dimensionally interchangeable with other major manufacturers.**

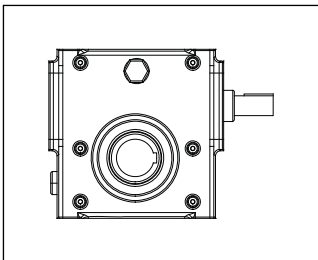

Standard single reduction reducer unit.

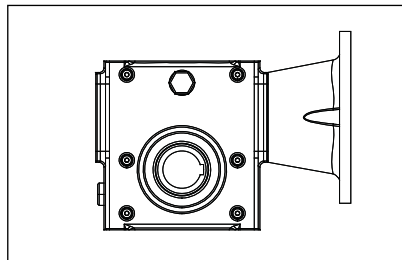

Motor ready unit

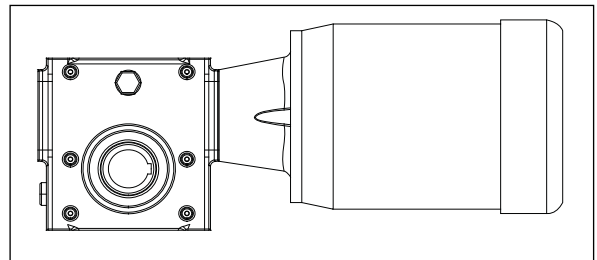

Motorized Reducer unit

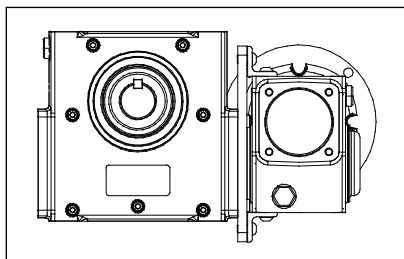

Motorized Double Reduction Reducer unit

# TABLE OF CONTENT

» <i>General Description</i> .....	5
» <i>Unit Designation</i> .....	6
» <i>Explanation &amp; Use of Ratings &amp; Service Factors</i> .....	7
» <i>Load Classification by Application</i> .....	8
» <i>Selection Procedure Motorized Units</i> .....	9
» <i>Selection Procedure Reducer Units</i> .....	11
» <i>Output Shaft Option</i> .....	13
» <i>Output Bore Standard</i> .....	14
» <i>Output Bore Optional</i> .....	15
» <i>Motor Adaptors NEMA</i> .....	16
» <i>Mounting Positions</i> .....	17
» <i>Mounting Positions</i> .....	18
» <i>Primary Unit Mounting Positions</i> .....	19
» <i>Additional Motor Features</i> .....	20
» <i>Additional Gear Unit Features</i> .....	21
<b>INSTALLATION MAINTENANCE &amp; LUBRICATION</b> -----	22
» <i>Installation &amp; Maintenance</i> .....	23
» <i>Approved Lubricants</i> .....	25
» <i>Shaft Alignment</i> .....	26
<b>MOTORIZED</b> -----	28
» <i>Motor Details - NEMA Standard Motors</i> .....	30
» <i>Motorized Selection Tables</i> .....	31
» <i>Motorized Dimensions - Single Reduction Units</i> .....	41
» <i>Motorized Dimensions - Double Reduction Units</i> .....	47
<b>DIMENSIONAL COMPARISON</b> -----	54
» <i>Dimension Interchangeability</i> .....	55
<b>REDUCER</b> -----	62
» <i>Overhung Loads on Shafts</i> .....	63
» <i>Reducer Ratings - Single Reduction</i> .....	64
» <i>Reducer Ratings - Double Reduction</i> .....	65
» <i>Reducer Ratings - Single Reduction</i> .....	66
» <i>Reducer Ratings - Double Reduction</i> .....	67
» <i>Reducer Dimensions - Single Reduction Units</i> .....	68
» <i>Reducer Dimensions - Double Reduction Units</i> .....	73
» <i>Customer Shaft Dimensions</i> .....	79
» <i>Alternate Shaft - Mounting Methods</i> .....	80
» <i>Torque Arm Details</i> .....	81
<b>KIT SELECTION</b> -----	83
» <i>GearHead Kits</i> .....	84
» <i>NEMA Motor Adapter Kits</i> .....	85
» <i>Input Shaft Kits</i> .....	86
» <i>Shaft &amp; Base Kits</i> .....	87
» <i>Shaft Mount Bushing Kit</i> .....	88
» <i>Output Bracket &amp; Torque Arm Mount Kits</i> .....	89
» <i>Double Reduction Units - Mounting Kits</i> .....	90

## Series B

Series B right angle gearmotors and reducers provide a very compact solution to meet the demands of today's industrial drive requirements. With over 200 years of cumulative experience in design and manufacturing has resulted in a range of right angle products offering high load carrying capacity, high efficiency, quiet running and reliability with lasting performance.

### Single and Double Reduction Units

Series B is offered in unit sizes 02, 03, 04, 05, 06, 08, 09, 10 and 11 based on a single universal gear case for each size, giving a high degree of common parts and interchangeability. Units can be mounted in all mounting positions and provide a choice of shaft arrangements for either motorized or reducer versions. Motors can be close coupled via a patented motor connection system offering power coverage from 0.25 HP to 10 HP.

All units are designed with hollow output shaft as standard, solid output shafts can be fitted allowing hand of assembly to be changed without dismantling the unit. Double extended output shafts are also available.

Series B offers a choice of 10 standard ratios from 5/1 to 60/1 in Single Reduction units and 15 standard ratios from 100/1 to 3600/1 in Double Reduction units. All units are lubricated for life to reduce maintenance to a minimum.

### Motorized Units with Patented Motor Connection

Units are designed to be close coupled with standard dimension NEMA frame motors. The Patented Motor Connection system eliminates fretting corrosion allowing the easy removal of motors from the gearbox to minimize down time and maintenance time.

### Lubricated For Life

Series B units are factory filled with high quality synthetic lubricant which means:

- The product arrives ready for use
- No oil level checks, topping up, draining or re-filling
- No danger of starting up without lubricant
- Mount in any location, however inaccessible

### Sealed and Non-Vented

Series B units are sealed against the environment and operate without the need to be vented. This allows the product to be shipped factory filled yet doesn't require vents to be retrofitted in the correct position prior to operation. It also offers protection against the ingress of contaminants in the field and eliminates a leak path.

*As improvements in design are being made continually this specification is not to be regarded as binding in detail and drawings and capacities are subject to alteration without notice. Certified drawings will be sent on request.*

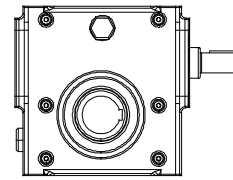

**Standard Single Reduction Units**

B	0	5	1	0	1	5	.	W	R	A	-	1	-	-	-	-	-	-	-
---	---	---	---	---	---	---	---	---	---	---	---	---	---	---	---	---	---	---	---

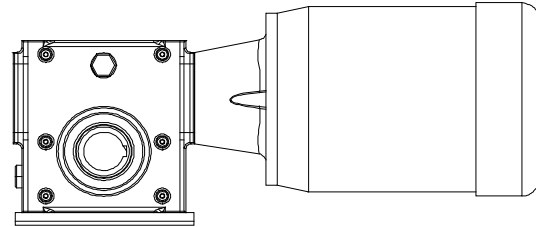

**Motorized Units with Horizontal Base**

B	0	4	1	0	2	0	.	B	M	A	T	1	-	1	.	0	B	-	-
---	---	---	---	---	---	---	---	---	---	---	---	---	---	---	---	---	---	---	---

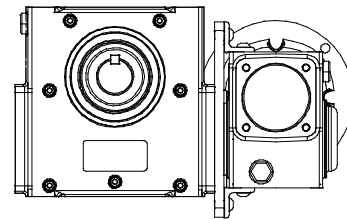

**Motorized Double Reduction Unit**

B	0	4	2	0	2	0	.	W	M	A	T	1	-	1	.	0	B	-	-
---	---	---	---	---	---	---	---	---	---	---	---	---	---	---	---	---	---	---	---

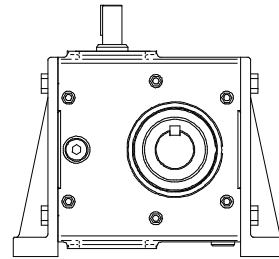

**Units with End Mounted Base**

B	0	6	1	0	4	0	.	J	R	P	-	5	-	-	-	-	-	-	-
---	---	---	---	---	---	---	---	---	---	---	---	---	---	---	---	---	---	---	---

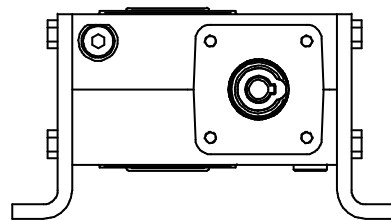

**Units with Vertical Base**

B	0	8	1	0	3	0	.	L	R	A	-	4	-	-	-	-	-	-	-
---	---	---	---	---	---	---	---	---	---	---	---	---	---	---	---	---	---	---	---

\* Typical unit designations.

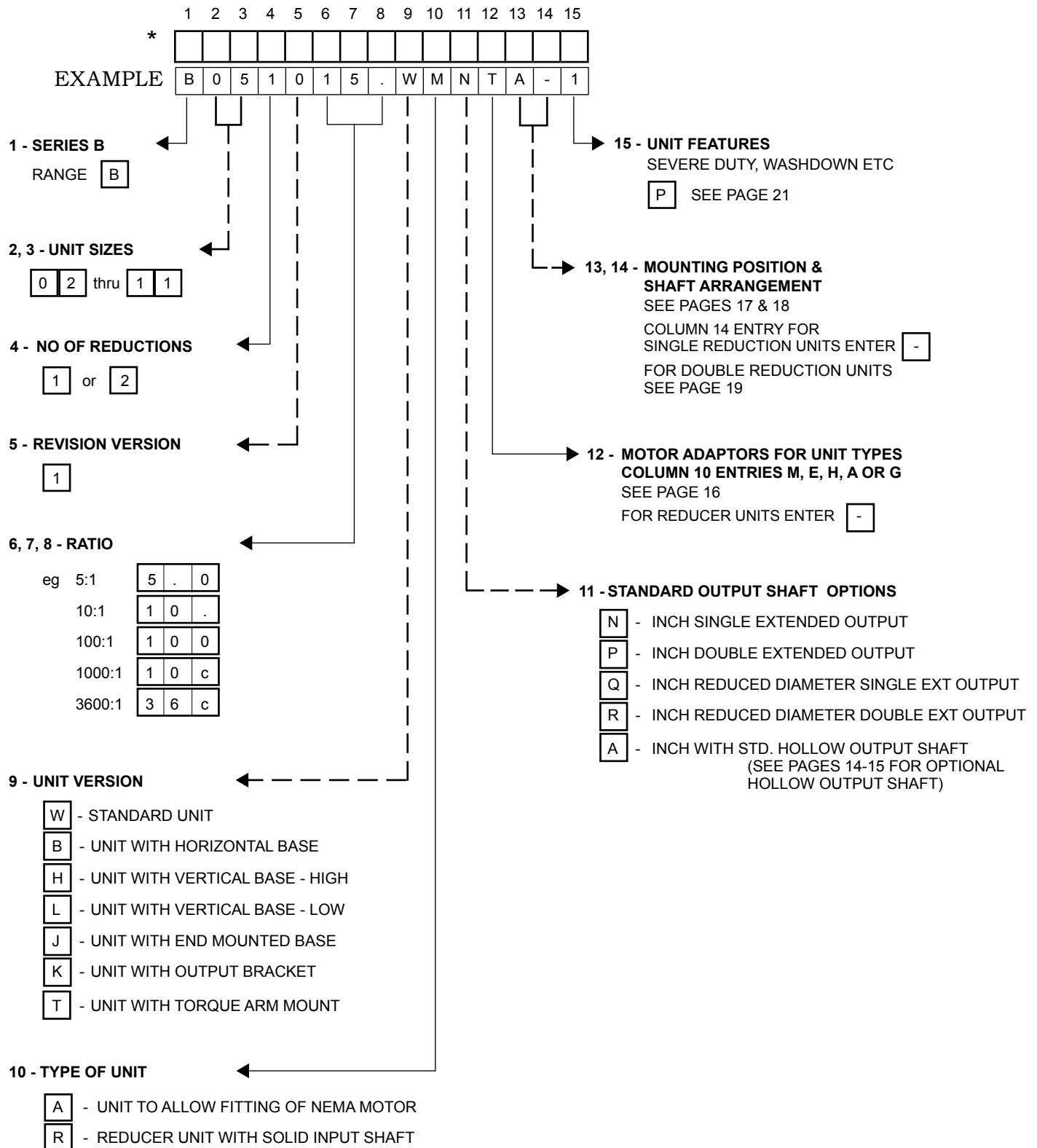

\* THIS PAGE MAY BE PHOTOCOPIED ALLOWING THE CUSTOMER TO ENTER THEIR ORDER.

# Series B

# Explanation & Use of Ratings & Service Factors

Gear unit selection is made by comparing actual loads with catalog ratings. Catalog ratings are based on a standard set of loading conditions, whereas actual load conditions vary according to type of application. Service Factors are therefore used to calculate an equivalent load to compare with catalog ratings. i.e. Equivalent Load = Actual Load x Service Factor

Two types of Service Factor must be considered: Mechanical Service Factor  $F_m$  and Thermal Service Factor  $F_t$

Mechanical ratings and service factor  $F_m$   
Mechanical ratings measure capacity in terms of life and/or strength, assuming 10 hr/day continuous running under uniform load conditions.

Catalog ratings allow for an 100% overload at starting, braking or momentarily during operation for a total of once per hour for each hour of operation.

The unit selected must therefore have a catalog rating at least equal to half maximum overload.

Mechanical Service Factor  $F_m$  (Table 1) is used to modify the actual load according to daily operating time, and type of loading.

Load characteristics for a wide range of applications are detailed in Table 3 opposite, which are used in deciding the appropriate Service Factor  $F_m$  from Table 1.

If overloads can be calculated, or accurately assessed, actual loads should be used instead of  $F_m$ .

For units subject to frequent stop/start overloads in excess of 10 times per day, contact our Application Engineers.

For applications where high inertia loads are involved e.g. crane travel drives, slewing motion etc., unit selection should be referred to our Application Engineers.

Thermal ratings and service factors  
The Thermal ratings are a measure of the gear units ability to dissipate heat. If they are exceeded the lubricant may overheat and breakdown, resulting in gear failure.

Catalog thermal limitations are based on the unit operating continuously in an environment with an ambient temperature equal to 68°F. The thermal rating is affected by ambient temperature. To account for these varying conditions, the service factors given in table 2 should be applied to the catalog thermal ratings as follows:

$$P_{therm} = (P_t \times F_t \times \text{efficiency}) / 100$$

$P_t$  = Catalog input power thermal rating (HP)

$P_{therm}$  = Allowable output power thermal rating (HP)

$F_t$  = Service factor for ambient temperature (see Table 2)

Prime mover	Duration of service hrs per day	Load classification-driven machine		
		Uniform	Moderate Shock	Heavy Shock
Electric motor, steam turbine or hydraulic motor	Under 3	0.80	1.00	1.50
	3 to 10	1.00	1.25	1.75
	Over 10	1.25	1.50	2.00
Multi-cylinder internal combustion engine	Under 3	1.00	1.25	1.75
	3 to 10	1.25	1.50	2.00
	Over 10	1.50	1.75	2.25
Single cylinder internal combustion engine	Under 3	1.25	1.50	2.00
	3 to 10	1.50	1.75	2.25
	Over 10	1.75	2.00	2.50

Ambient Temperature °F	-20	0	20	40	60	68	80	100	120
Factor $F_t$	1.64	1.50	1.36	1.22	1.07	1.00	0.92	0.77	0.63

**General**  
When selecting units, use actual load required to be transmitted, not rating of prime mover. Wherever possible use required output torque (lb-in). Catalog also gives input power rating (HP), being the power required from prime mover allowing for gear unit efficiency. When units transmit less than rated output torque, required input power may be reduced pro-rata to decide capacity of prime mover.



### EXAMPLE APPLICATION DETAILS

Absorbed power of driven machine = 0.50 HP  
 Output speed of gearbox or Input speed of machine = 58 RPM  
 Application = Uniformly loaded belt conveyor  
 Duration of service (hours per day) = 24hrs  
 Ambient temperature = 68°F

### 1 DETERMINE MECHANICAL SERVICE FACTOR (Fm)

Refer to Load Classification by Application, table 3, page 8  
 Application = Uniformly loaded belt conveyor

Conveyors-uniformly loaded or fed		U = Uniform load
apron	U	
assembly	U	
belt	U	
bucket	U	
chain	U	

Refer to mechanical service factor (Fm), table 1, page 7

Duration of service (hours per day) = 24hrs

Prime mover	Duration of service hrs per day	Load classification-drive	
		Uniform	Moderate Shock
Electric motor, steam turbine or hydraulic motor	Under 3	0.80	1.00
	3 to 10	1.00	1.25
	Over 10	1.25	1.50

### 2 DETERMINE REQUIRED OUTPUT TORQUE AT GEARBOX OUTPUTSHAFT

$$\text{Output Torque} = \frac{63025 \times \text{Input HP} \times \text{Ratio} \times \text{Reducer Efficiency}}{\text{Input speed}}$$

$$\text{Output Torque} = \frac{63025 \times 0.50 \times 30 \times 0.72}{1750}$$

$$\text{Output Torque} = 389 \text{ Lb. in}$$

See pages 65 - 68 for reducer efficiencies

### 3 SELECT GEARMOTOR

Refer to selection table one motor size larger than absorbed power.  
 Absorbed power = 0.50 HP, therefore refer to 0.50 HP selection table, page 33.

Required output speed of gearbox = 58 RPM

0.50 HP	OUTPUT SPEED	RATIO	OUTPUT TORQUE (LB-IN)	MECH S.F.	OHL (LB)	UNIT DESIGNATION	MOTOR FRAME	
							NEMA	IEC
4 Pole 1750 RPM	117	15	223	3.03	710	B 0 4 1 0 1 5 . _ M _ _ _ . 5 0 B _ _	56C	71
	88	20	281	2.40	710	2 0 .		
	70	25	337	2.16	710	2 5 .		
	58	30	387	1.81	710	3 0 .		
	44	40	462	1.36	710	4 0 .		
	35	50	526	1.16	710	5 0 .		
	29	60	574	0.99	710	6 0 .		

## 4 CHECK OUTPUT TORQUE

Output torque of selected unit must be equal or more than required output torque at gearbox outputshaft.  
 Required output torque at gearbox outputshaft = 389 lb.in

Selected unit's output torque = 700 lb.in, therefore unit is acceptable (See B0410 30:1 reducer rating on page 65)

## 5 CHECK SERVICE FACTOR

Service factor (Fm) of selected unit must be equal or more than required service factor.

Required service factor of gearbox = 1.25

0.50 HP	OUTPUT SPEED	RATIO	OUTPUT TORQUE (LB-IN)	MECH S.F.	OHL (LB)	UNIT DESIGNATION	MOTOR FRAME	
							NEMA	IEC
4 Pole 1750 RPM	117	15	223	3.03	710	B 0 4 1 0 1 5 . _ M _ _ _ _ . 5 0 B _ _	56C	71
	88	20	281	2.40	710	2 0 .		
	70	25	337	2.16	710	2 5 .		
	58	30	387	1.81	710	3 0 .		
	44	40	462	1.36	710	4 0 .		
	35	50	526	1.16	710	5 0 .		
	29	60	574	0.99	710	6 0 .		

Selected unit's service factor (Fm) = 1.81, therefore unit is acceptable.

## 6 CHECK OVERHUNG LOADS

If sprocket, gear, etc is mounted on the outputshaft then refer to Overhung Loads Procedure, page 64, and compare with allowable overhung load of selected unit

Allowable overhung load (LB) must be equal or more than calculated overhung load (P)

0.50 HP	OUTPUT SPEED	RATIO	OUTPUT TORQUE (LB-IN)	MECH S.F.	OHL (LB)	UNIT DESIGNATION	MOTOR FRAME	
							NEMA	IEC
4 Pole 1750 RPM	117	15	223	3.03	710	B 0 4 1 0 1 5 . _ M _ _ _ _ . 5 0 B _ _	56C	71
	88	20	281	2.40	710	2 0 .		
	70	25	337	2.16	710	2 5 .		
	58	30	387	1.81	710	3 0 .		
	44	40	462	1.36	710	4 0 .		
	35	50	526	1.16	710	5 0 .		
	29	60	574	0.99	710	6 0 .		

NOTE: If any of the following conditions occur then consult our Application Engineers:

- a) Inertia of the Driven Machine (Referred to motor speed) >10  
 Inertia of Gear Unit plus Motor
- b) Ambient temperature is above 120°F

### EXAMPLE APPLICATION DETAILS

Absorbed power of driven machine = 0.375 HP  
 Output speed of gearbox or Input speed of machine = 30 RPM  
 Application = Uniformly loaded belt conveyor  
 Duration of service (hours per day) = 24 hrs  
 Motor speed = 3 phase electric motor, 4 pole, 1750 RPM  
 Ambient temperature = 68°F

### 1 DETERMINE RATIO OF GEARBOX REQUIRED

$$\frac{\text{Motor speed}}{\text{Gearbox output speed}} = \frac{1750}{30} = 58.33$$

Refer to rating tables (pages 65 - 68) for nearest standard ratio = 60:1

### 3 DETERMINE REQUIRED MECHANICAL OUTPUT TORQUE CAPACITY OF GEARBOX

$$\text{Absorbed output torque} = \frac{\text{Absorbed power} \times 63025}{\text{Gearbox output speed}}$$

$$\frac{0.375 \times 63025}{30} = 788 \text{ lb.in}$$

$$\text{Required mechanical output torque} = \text{Absorbed output torque} \times F_m$$

$$788 \times 1.25 = 985 \text{ lb.in}$$

\*\*Note: Reducer efficiency not used. Generated torque will vary based on efficiency

### 2 DETERMINE MECHANICAL SERVICE FACTOR (Fm)

Refer to Load Classification by Application, table 3, page 7

Application = uniformly fed, belt conveyor

Conveyors-uniformly loaded or fed	
apron	U
assembly	U
belt	U
bucket	U
chain	U

U = Uniform loading

Refer to mechanical service factor (Fm), table 1, page 6

Duration of service (hours per day) = 24 hrs

Prime mover	Duration of service-hrs per day	Load classification-drive	
		Uniform	Moderate Shock
Electric motor, steam turbine or hydraulic motor	Under 3	0.80	1.00
	3 to 10	1.00	1.25
	Over 10	1.25	1.50

Therefore mechanical service factor (Fm) = 1.25

### 4 DETERMINE SIZE OF GEAR BOX REQUIRED

Refer to ratings tables, Input speed = 1750RPM, therefore refer to page 65.

RATIO	OUTPUT SPEED	CAPACITY	SIZE OF UNIT								
			B0210	B0310	B0410	B0510	B0610	B0810	B0910	B1010	B1110
60	29	Input Power HP (mech)	0.29	0.38	0.50	0.64	0.98	1.24	1.70	2.05	2.52
		Input Power HP (therm)	0.42	0.55	0.81	0.92	1.31	1.79	2.13	2.70	2.88
		Output Torque lb-in (mech)	272	404	570	782	1305	1699	2427	2986	3739
		Efficiency	0.43	0.49	0.53	0.57	0.61	0.64	0.66	0.67	0.69

Mechanical output torque capacity must be equal or more than required mechanical output torque capacity of gear box. Required mechanical output torque capacity = 985 lb-in. At a 60:1 ratio, nominal output speed 29 an B0610 unit has a mechanical output torque capacity of 1305 lb-in. Therefore the unit is acceptable.

### 5 DETERMINE REQUIRED OUTPUT TORQUE AND POWER

(Based on known reducer running efficiency)

Refer to ratings tables to determine gear unit efficiency

RATIO	OUTPUT SPEED	CAPACITY	SIZE OF UNIT								
			B0210	B0310	B0410	B0510	B0610	B0810	B0910	B1010	B1110
60	29	Input Power HP (mech)	0.29	0.38	0.50	0.64	0.98	1.24	1.70	2.05	2.52
		Input Power HP (therm)	0.42	0.55	0.81	0.92	1.31	1.79	2.13	2.70	2.88
		Output Torque lb-in (mech)	272	404	570	782	1305	1699	2427	2986	3739
		Efficiency	0.43	0.49	0.53	0.57	0.61	0.64	0.66	0.67	0.69

Running efficiency of B0610 60:1 at 1750 RPM = 61%

$$\text{Output Torque} = \frac{\text{63025} \times \text{Input Power} \times \text{Ratio} \times \text{Efficiency}}{\text{Input RPM}}$$

$$\text{Output Torque} = \frac{63025 \times 0.375 \times 60 \times 0.61}{1750}$$

Output Torque = 494 Lb. in (This is the actual output torque produced with 0.375 Hp input power.)

If the application requires greater output torque then the input power must be increased, in which case the input power rating of the reducer must be checked.

$$\text{Required motor power} = \frac{\text{Input power}}{\text{Efficiency}} \times 100 = \frac{0.375}{61} \times 100 = 0.615 \text{ HP}$$

Next largest motor is 0.75 Hp (The B0610 60:1 is rated for 0.98 Hp and is acceptable)

## 6 DETERMINE THERMAL SERVICE FACTOR (Ft)

Refer to table 2, page 7

Ambient temperature = 68°F

Ambient temperature °F	-20	0	20	40	60	68
Factor Ft	1.64	1.50	1.36	1.22	1.07	1.0

$$F_t = 1.0$$

## 7 CHECK THERMAL CAPACITY OF GEARBOX SELECTED

### DETERMINE THERMAL INPUT POWER CAPACITY (Pt)

Refer to ratings tables

RATIO	OUTPUT SPEED	CAPACITY	SIZE OF UNIT								
			B0210	B0310	B0410	B0510	B0610	B0810	B0910	B1010	B1110
60	29	Input Power HP (mech)	0.29	0.38	0.50	0.64	0.98	1.24	1.70	2.05	2.52
		Input Power HP (therm)	0.42	0.55	0.81	0.92	1.31	1.79	2.13	2.70	2.88
		Output Torque lb-in (mech)	272	404	570	782	1305	1699	2427	2986	3739
		Efficiency	0.43	0.49	0.53	0.57	0.61	0.64	0.66	0.67	0.69

$$P_t = 1.31 \text{ HP}$$

## 8 DETERMINE ALLOWABLE OUTPUT POWER THERMAL RATING (P<sub>therm</sub>)

$$\begin{aligned} P_{\text{therm}} &= \frac{P_t \times F_t \times \text{efficiency}}{100} \\ &= \frac{1.31 \times 1.0 \times 58}{100} \\ &= 0.80 \text{ HP} \end{aligned}$$

Thermal output power capacity (P<sub>therm</sub>) must be equal or more than absorbed output power to drive machine

$$\text{Absorbed output power} = 0.375 \text{ HP} \quad P_{\text{therm}} = 0.80 \text{ HP}$$

Therefore unit is acceptable

## 9 CHECK OVERHUNG LOADS

If sprocket, gear, etc is mounted on the input or output shaft then refer to Overhung loads procedure, page 64

NOTE: If any of the following conditions occur then consult our Application Engineers:

- a)  $\frac{\text{Inertia of the Driven Machine (Referred to motor speed)}}{\text{Inertia of Gear Unit plus Motor}} > 10$
- b) Ambient temperature is above 120°F
- or c) The unit is required without a fan

## COLUMN 11 ENTRY

### INCH SERIES SHAFTS

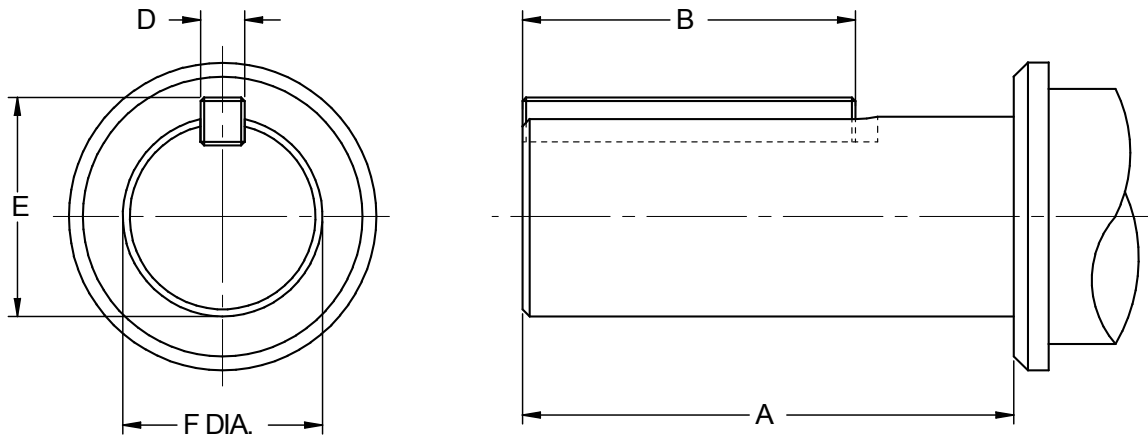

Unit Size	Type of Output Shaft	Column 11 Entry		A	B	D	E	F dia.
		Single Extended	Double Extended					
B02	Standard Inch (in)	N	P	1.876	1.000	0.188 ± 0.001	0.828	0.7495 ± 0.0005
	Reduced Dia. (in)	Q	R	1.876	1.000	0.188 ± 0.001	0.701	0.6245 ± 0.0005
B03	Standard Inch (in)	N	P	1.989	1.125	0.188 ± 0.001	0.828	0.7495 ± 0.0005
B04	Standard Inch (in)	N	P	1.967	1.250	0.250 ± 0.001	1.105	0.9995 ± 0.0005
	Reduced Dia. (in)	Q	R	1.967	1.250	0.188 ± 0.001	0.955	0.8745 ± 0.0005
B05	Standard Inch (in)	N	P	2.387	1.500	0.250 ± 0.001	1.232	1.1245 ± 0.0005
	Reduced Dia. (in)	Q	R	2.387	1.500	0.250 ± 0.001	1.105	0.9995 ± 0.0005
B06	Standard Inch (in)	N	P	2.767	1.875	0.250 ± 0.001	1.232	1.1245 ± 0.0005
B08	Standard Inch (in)	N	P	2.677	1.938	0.375 ± 0.001	1.660	1.4995 ± 0.0005
	Reduced Dia. (in)	Q	R	2.677	1.938	0.250 ± 0.001	1.232	1.1245 ± 0.0005
B09	Standard Inch (in)	N	P	3.797	2.000	0.375 ± 0.001	1.660	1.4995 ± 0.0005
	Reduced Dia. (in)	Q	R	3.797	2.000	0.250 ± 0.001	1.358	1.2495 ± 0.0005
B10	Standard Inch (in)	N	P	3.831	2.250	0.375 ± 0.001	1.660	1.4995 ± 0.0005
	Reduced Dia. (in)	Q	R	3.831	2.250	0.312 ± 0.001	1.510	1.3745 ± 0.0005
B11	Standard Inch (in)	N	P	4.148	2.625	0.500 ± 0.001	2.087	1.8745 ± 0.0005
	Reduced Dia. (in)	Q	R	4.148	2.625	0.375 ± 0.001	1.787	1.6245 ± 0.0005

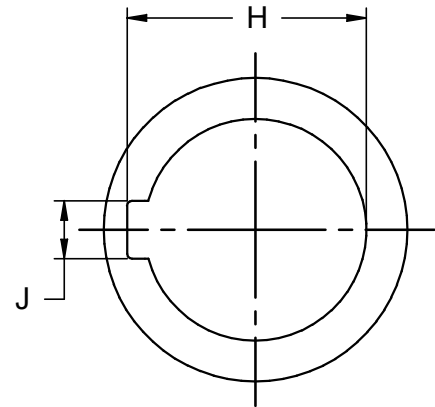
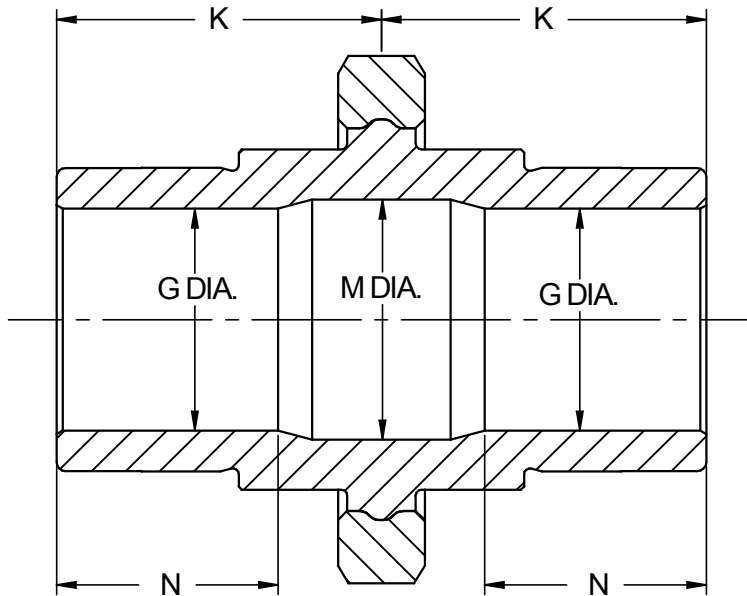

OUTPUT BORE STANDARD

Unit Size	Type of Output Bore	Column 11 Entry	G dia.	H	J	K	M	N
B02	Standard Inch (in)	A	1.0005 ± 0.0005	1.089	0.251 ± 0.001	1.928	1.119	1.142
B03	Standard Inch (in)	A	1.0005 ± 0.0005	1.088	0.251 ± 0.001	2.124	1.119	1.142
B04	Standard Inch (in)	A	1.4380 ± 0.0005	1.550	0.376 ± 0.001	2.146	1.556	1.437
B05	Standard Inch (in)	A	1.4380 ± 0.0005	1.550	0.376 ± 0.001	2.106	1.556	1.437
B06	Standard Inch (in)	A	1.4380 ± 0.0005	1.550	0.376 ± 0.001	2.126	1.556	1.437
B08	Standard Inch (in)	A	1.9380 ± 0.0005	2.104	0.501 ± 0.001	2.717	2.056	1.937
B09	Standard Inch (in)	A	2.1880 ± 0.0005	2.359	0.501 ± 0.001	2.717	2.306	2.189
B10	Standard Inch (in)	A	2.1880 ± 0.0005	2.359	0.501 ± 0.001	2.992	2.306	2.189
B11	Standard Inch (in)	A	2.9380 ± 0.0005	3.151	0.751 ± 0.001	3.327	3.056	2.937

OPTIONAL INCH BORES AVAILABLE WITH ADDITIONAL BUSHING KITS.  
REFER TO FOLLOWING PAGE FOR DETAIL.

## COLUMN 11 ENTRY

Bore Diameter	UNIT SIZE								
	B02	B03	B04	B05	B06	B08	B09	B10	B11
0.625	E	E							
0.875	--	F	E						
1.000	A	A	F	E	E				
1.125			G	F	F	E			
1.188			--	G	G	--			
1.250			J	J	J	--			
1.438			A	A	A	J	E	E	E
1.750						--	F	F	--
1.938						A	G	G	--
2.188							A	A	G
2.438									J
2.938									A

### Optional Metric Bore

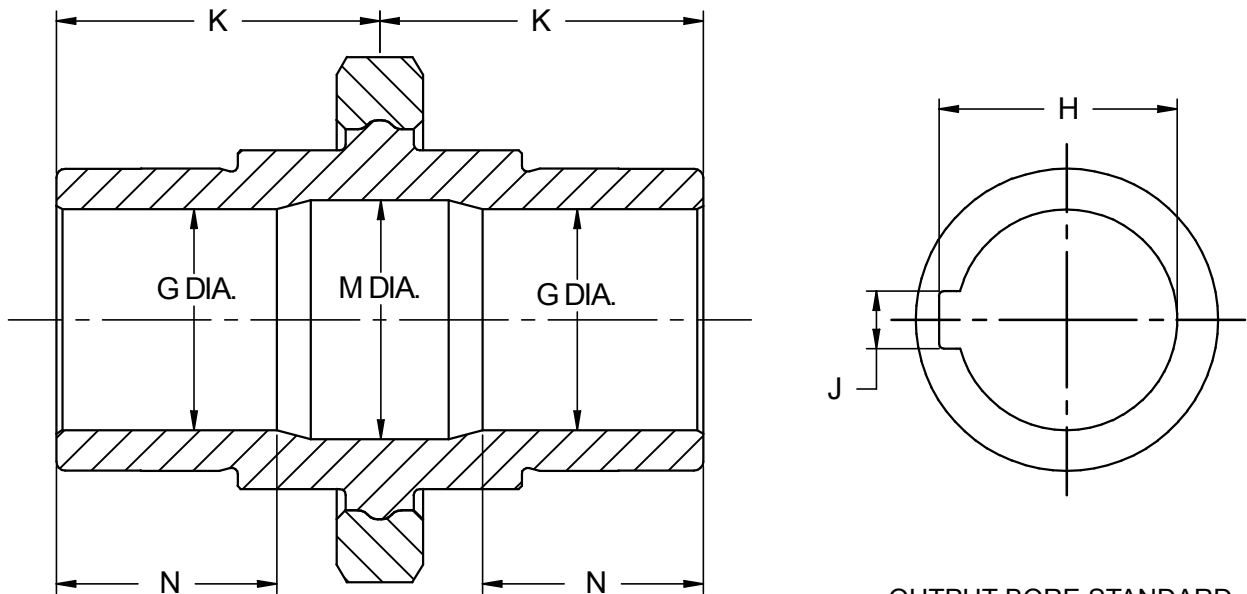

OUTPUT BORE STANDARD

Unit Size	Type of Output Bore	Column 11 Entry	G dia.	H	J	K	M	N
B02	Standard metric (mm)	M	20 + 0.013	22.85	6.00 + 0.015	48.971	28.42	29.007
B03	Standard metric (mm)	M	25 + 0.013	28.30	8.00 + 0.018	48.971	28.42	29.007
B04	Standard metric (mm)	M	35 + 0.013	38.30	10.00 + 0.018	54.508	39.52	36.500
B05	Standard metric (mm)	M	35 + 0.013	38.30	10.00 + 0.020	53.492	39.52	36.500
B06	Standard metric (mm)	M	35 + 0.013	38.30	10.00 + 0.020	54.000	39.52	36.500

## NEMA C FACE MOTOR ADAPTOR KITS

### Single Stage Units

Motor Frame	Unit Size								
	B0210	B0310	B0410	B0510	B0610	B0810	B0910	B1010	B1110
56C	U	T	T	T	T	Q	Q	Q	Q
143TC/145TC	W	V	V	V	V	R	R	R	R
182TC/184TC		X	X	X	X	T	T	T	T
213TC/215TC						V	V	V	V

### Double Reduction Units

Unit Size					
B0520	B0620	B0820	B0920	B1020	B1120
U	U	T	T	T	T
W	W	V	V	V	V
		X	X	X	X

# Series B

# Mounting Positions

NOTE #1: "FIRST ANGLE" PROJECTION USED IN VIEWS BELOW

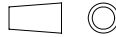

NOTE #2: SINCE SERIES B IS A FULLY SEALED UNIT. THE CONFIGURATIONS SHOWN MAY BE MOUNTED IN ANY ORIENTATION.

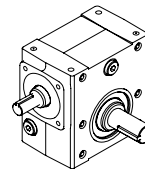

NOTE #3: HAND OF ASSEMBLY VIEWS SHOWN LOOKING INTO HIGH SPEED (INPUT) SHAFT



COLUMN 13 ENTRY		Std Unit With Hollow Output Shaft	Std Unit With Solid Output Shaft	Base Mount With Hollow Output Shaft	Base Mount With Solid Output Shaft	Output Bracket With Hollow Shaft	Output Bracket with Single Ext. Solid Shaft	Vertical Base With Hollow Shaft	Vertical Base With Single Ext. Solid Shaft
1									
A									
B									
C									
D									
2									
E									
F									

NOTE #1: "FIRST ANGLE" PROJECTION USED IN VIEWS BELOW



NOTE #2: SINCE SERIES B IS A FULLY SEALED UNIT. THE CONFIGURATIONS SHOWN MAY BE MOUNTED IN ANY ORIENTATION. CONSIDERATION MUST BE GIVEN FOR REDUCERS MOUNTED WITH THE INPUT DOWN TO PREVENT SEAL LEAKS.

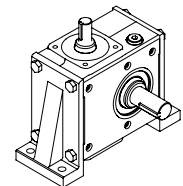

NOTE #3: HAND OF ASSEMBLY VIEWS SHOWN LOOKING TOWARD BASE ON HIGH SPEED (INPUT) SHAFT SIDE



COLUMN 13 ENTRY		End Mount Base With Hollow Output Shaft	End Mount Base With Solid Output Shaft
5			
S			
T			

# Series B

# Mounting Positions

NOTE #1: "FIRST ANGLE" PROJECTION USED IN VIEWS BELOW



NOTE #2: SINCE SERIES B IS A FULLY SEALED UNIT. THE CONFIGURATIONS SHOWN MAY BE MOUNTED IN ANY ORIENTATION.

NOTE #3: HAND OF ASSEMBLY VIEWS SHOWN LOOKING INTO SPEED (INPUT) SHAFT

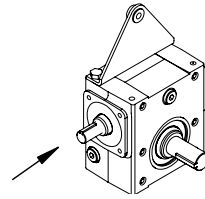

COLUMN 13 ENTRY		Torque Arm With Hollow Shaft	Torque Arm With Dbl. Ext. Solid Shaft	Torque Arm With Single Ext. Solid Shaft
J				
K				
L				
M				
N				
P				
Q				
R				

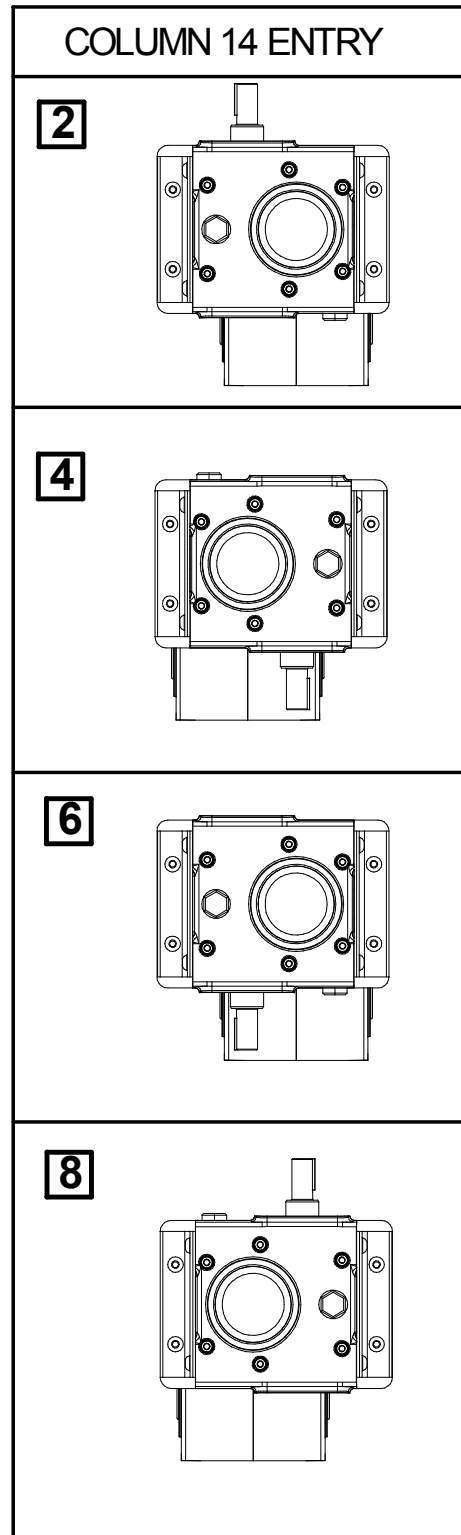
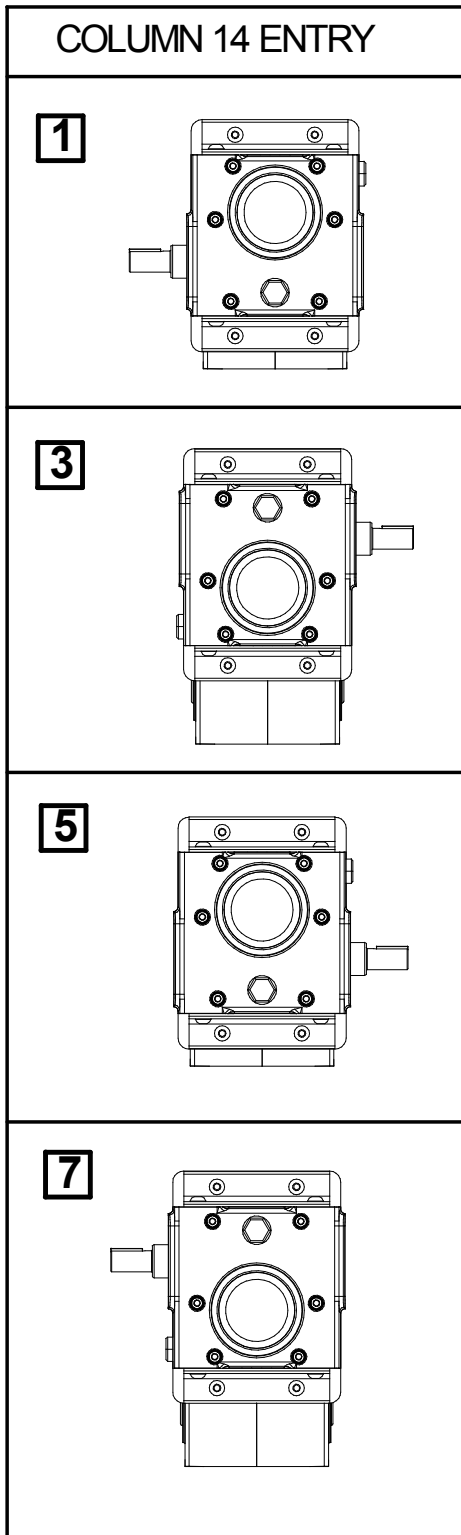

PRIMARY UNIT POSITION RELATIVE TO THE SECONDARY UNIT

MOUNTING POSITIONS 4 AND 6 NOT AVAILABLE FOR MOTORIZED UNITS

FOR SINGLE REDUCTION ENTER



## GEAR UNIT FEATURES - COLUMN 15 ENTRY

Column 15 Entry	Double Extended Input*	Severe Duty Option	Washdown Duty Option	Light Washdown Duty Option	Special Features
-					
G	●				
H	●	●			
J	●		●		
K	●			●	
P		●			
R				●	
S			●		
Z					●

\* Solid shaft extension to standard proportions on non drive end of input

### SPECIAL UNIT FEATURES - WASHDOWN

Available for all single reduction motorized reducers, with or without bases.

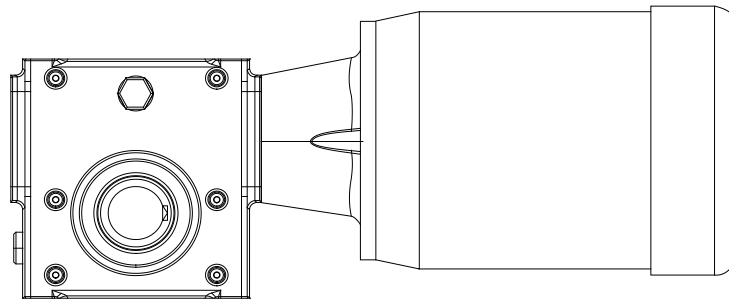

#### Standard Features

- Vent - free eliminating contamination of reducer
- Smooth flat exterior is easily washable

#### Severe Duty Option - Column 15 Entry H, P

- USDA approved white epoxy paint

#### Washdown Duty Option - Column 15 Entry J, S,

- USDA approved white epoxy paint
- Exposed portions of hollow output shaft plated for protection
- Unused, tapped holes plugged to simplify washdown
- Stainless steel fasteners
- Stainless steel solid output shafts

#### Light Washdown Duty Option - Column 15 Entry K, R

- Exposed portions of hollow output shaft plated for protection
- Unused, tapped holes plugged
- Stainless steel fasteners
- Stainless steel output shafts

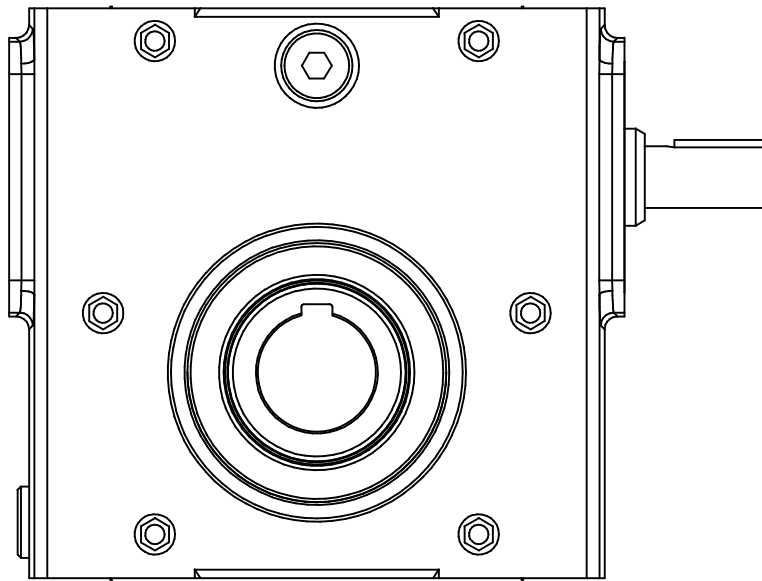

INSTALLATION MAINTENANCE  
& LUBRICATION

**SERIES B**

## 1. GENERAL INFORMATION

The following instructions will help you achieve a satisfactory installation of your Series B unit, ensuring the best possible conditions for a long and trouble free operation.

All units are tested and checked prior to shipment, a great deal of care is taken in packing and shipping arrangements to ensure that the unit arrives at the customer in the approved condition.

Optimum performance is best achieved by a process of gradual load increments, up to the full value, over the first 50 hours or so of their working life. During these early stages of running, sensible precautions should be taken to avoid overloads.

The gear unit operating temperature may be higher during this period of run-in. A progressive reduction in temperature may occur over many hours until the unit has reached its highest efficiency.

## 2. MOUNTING OF COMPONENTS TO EITHER THE UNIT INPUT OR OUTPUT SHAFT

Shaft dimensions and tolerances are on page 13.

- Items (such as gears, sprockets, couplings etc) should not be hammered onto these shafts since this would damage the shaft support bearings.
- The item should be pushed onto the shaft using hydraulic or hand press with the shaft supported at the opposite end.

## 3. WEATHER PROTECTION OF UNIT

All Series B units are provided with protection against normal weather conditions. Where units are to operate in extreme conditions, or where they are to stand for long periods without running, e.g. during plant construction, we should be notified when ordering so that arrangements for adequate protection can be made.

## 4. INSTALLATION

### 4.1 MOTORIZED AND REDUCERS

All sizes are factory filled with a high quality synthetic lubricant. They are 'Lubricated for Life' and require no routine maintenance in service.

### 4.2 MOUNTING TO CUSTOMER EQUIPMENT

Mounting the gearhead flange facing or feet to the customer equipment use screws to ISO grade 8.8 minimum.

Torque tighten to:

Screw Size	Tightening Torque	Tightening Torque
M6	88 lb-ins	7.3 lb-ft
M8	220 lb-ins	18.3 lb-ft
M10	450 lb-ins	37.5 lb-ft
M12	750 lb-ins	62.5 lb-ft
M16	1770 lb-ins	147.5 lb-ft
M20	3100 lb-ins	258.3 lb-ft
M24	5400 lb-ins	450.0 lb-ft

### 4.3 MOTOR CONNECTIONS TO MAINS

Connection of the electric motor to the mains supply should be made by a qualified person. The current rating of the motor will be identified on the motor plate, and correct sizing of the cables to electrical regulations is essential.

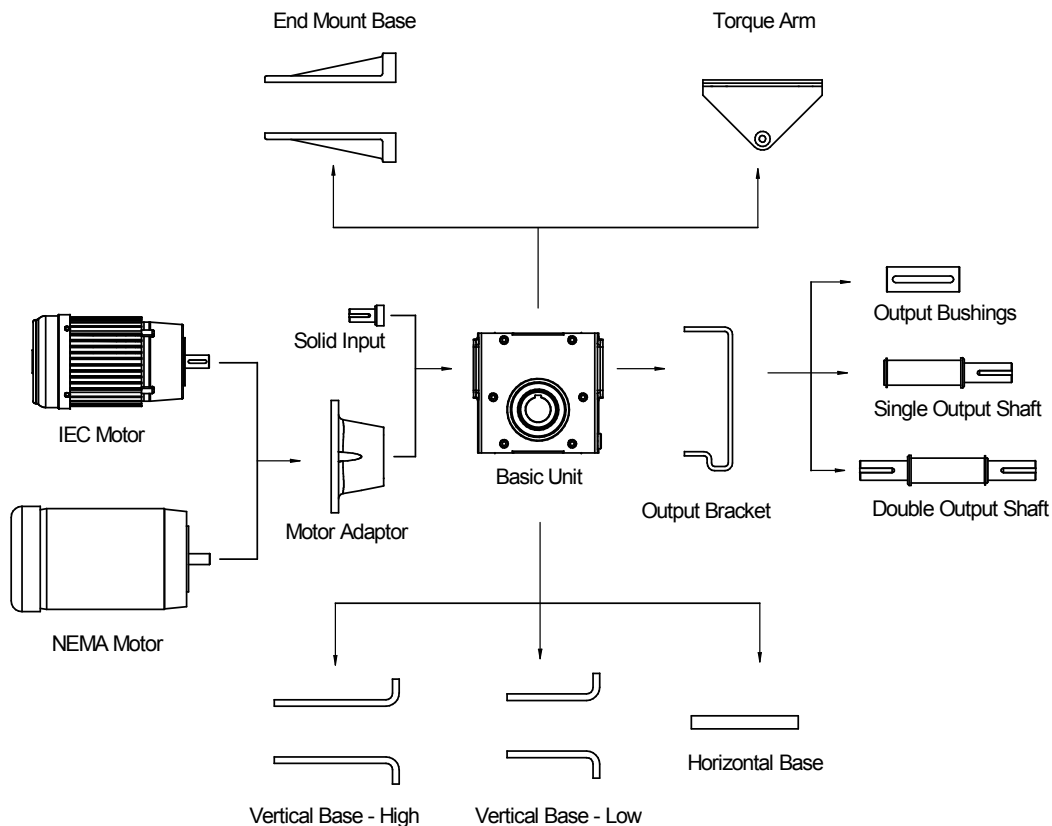

## BASE ASSEMBLY (TYPES B, H, L, J)

- 1 Clean shaft extension with petroleum spirit.
- 2 Remove paint from locating faces on gearcase with scraper and petroleum spirit.
- 3 Secure feet to gear case with nuts and bolts provided to thumb tightness, in required operating position.
- 4 Ensure foot pads are correctly seated.
- 5 Secure to foundations with bolts to thumb tightness and line up unit.
- 6 Tighten feet bolts to unit.
- 7 Check shaft alignment (see page 26) and tighten down bolts.

## OUTPUT SHAFT ASSEMBLY

- 1 Clean output shaft and bore in gear unit with petroleum spirit.
- 2 Fit keys into output shaft, ensuring they are firmly seated.
- 3 Press shaft into gear unit bore to give desired shaft handling (Left or Right), until firmly up against shaft shoulder.
- 4 Fit circlip into groove in shaft on opposite side to extension.

Series B units are factory filled with a high quality synthetic lubricant. They are “Lubricated for Life” and require no routine maintenance in service.

In the event of a major overhaul involving strip-down and re-assembly of the gear unit refer to Table 1 for a list of approved lubricants. Lubricant quantities are given in Tables 2 & 3.

Table 1 Approved Lubricants

**Type H Polyalphaolefin based synthetic lubricants**

These lubricants are suitable for ambient temperatures of 32°F to 104°F (0°C to 40°C); outside of this, please contact our Application Engineers

SUPPLIER	LUBRICANT RANGE	GRADE 7H
		OIL SUPPLIERS' CORRESPONDING DESIGNATIONS
Chevron-Texaco	Clarity Synthetic PMO	460 (-23)
Exxon Mobil Corporation	SHC 600 Series	634 (-34)

**DANGER** Numbers in brackets indicate recommended minimum operating temperature in °F. The unit must not run below this temperature

Table 2 Lubricant Quantities (liters)

Applicable for all mounting positions:

CONVERSION TABLE

Liters to US gallons = liters x 0.26  
 Liters to Imperial gallons = liters x 0.22

MOTORIZED or REDUCER		UNIT SIZE								
		B02	B03	B04	B05	B06	B08	B09	B010	B011
Oil Capacity	Quarts	0.14	0.26	0.34	0.45	0.58	0.96	1.48	2.00	1.70
	Liters	0.13	0.25	0.33	0.43	0.55	0.91	1.40	1.89	1.61

Table 3 Double Reduction Lubricant Quantities

Applicable for all mounting positions:

Unit Size	B0520		B0620		B0820		B0920		B1020		B1120	
	Primary	Secondary	Primary	Secondary	Primary	Secondary	Primary	Secondary	Primary	Secondary	Primary	Secondary
Quarts	0.14	0.60	0.14	0.80	0.34	1.25	0.34	1.80	0.45	2.60	0.45	2.21
Liters	0.13	0.57	0.13	0.76	0.33	1.18	0.33	1.70	0.43	2.46	0.43	2.09

## GENERAL INSTRUCTIONS

### SHAFT ALIGNMENT Coupling Connections

#### Angular Errors

- 1 Take up end float pushing in shaft ends.
- 2 Using thickness and feeler gauges, take readings in positions 1, 2, 3 and 4 (Fig 2).
- 3 Adjust unit by shimming under feet.

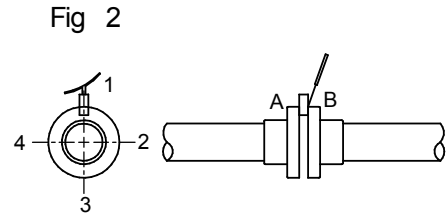
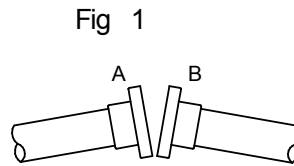

#### Eccentric Errors

- 1 Place straight edge across coupling halves at points 1, 2, 3 and 4 (Fig 4). If coupling diameters are not equal, use feeler gauge equal to half the difference in diameters.
- 2 If error is in vertical plane, adjust height of unit. If error is in horizontal plane, move unit transversely.

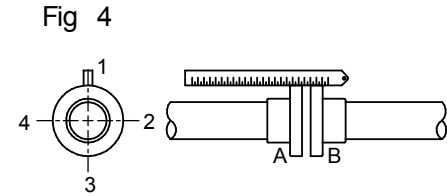
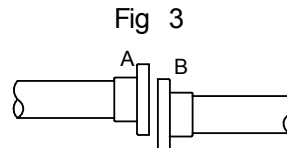

## CHAIN AND BELT DRIVES

Mount sprockets or pulleys as close to the gear unit as possible to avoid undue bearing loads and shaft deflection see Fig 5. Chains and belts should be sufficiently light as to prevent slip **OVER TIGHTENING CAN CAUSE DAMAGE TO THE UNIT.** Consult manufacturers' recommendations.

Check that driving and driven shafts are square and parallel using straight edge as in Fig 6.

Check horizontal shaft alignment using combined square and level as in Fig 7.

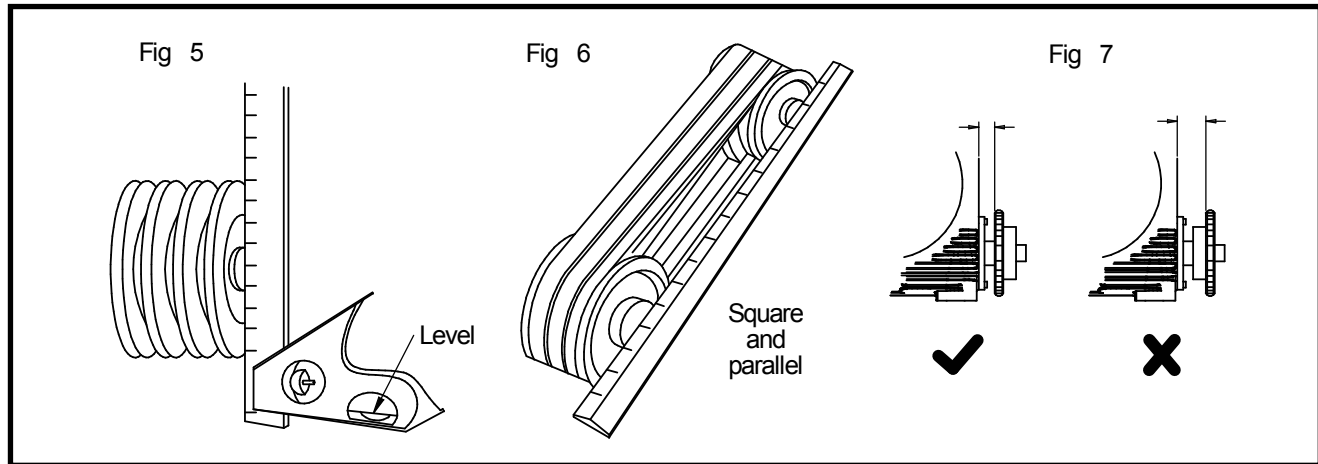

## FIT GUARDS IN ACCORDANCE WITH REGULATIONS

If a unit is to be subject to long term storage contact our Application Engineers.

### WARNING

The customer shall be responsible for the proper use of articles supplied by us, particularly the rotating shafts between their driving and driven members, and their guarding for safety. We shall not be responsible for any injury or damage sustained as a result of the improper use of the articles supplied.

Attention is hereby drawn to the danger of using naked lights in proximity of opening in gearboxes and gear units supplied by us, and the company shall not be liable for any claim for injury or damage arising from any action in contradiction of this warning.

## GENERAL SAFETY

Potential hazards which can be encountered during installation, maintenance and operation of drives is covered in greater detail in the product safety page at the back of this booklet.

Advice is also given on sensible precautions which need to be taken to avoid injury or damage. **PLEASE READ !**



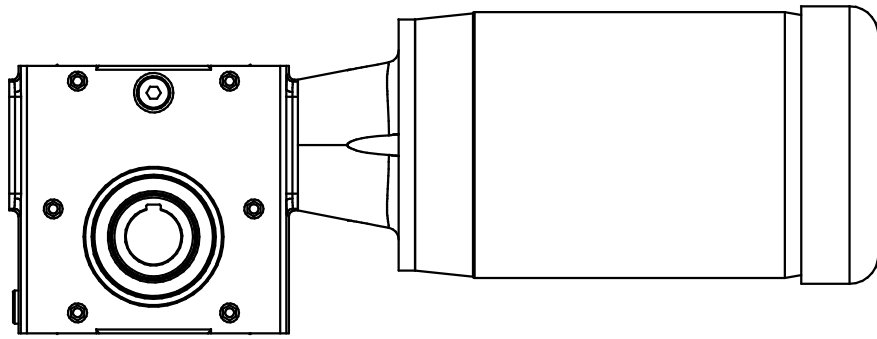

MOTORIZED

**SERIES B**

# Series B

# Motor Details - Metric IEC Standard Motors

## Metric IEC Standard Motors

B14 'C' FACE

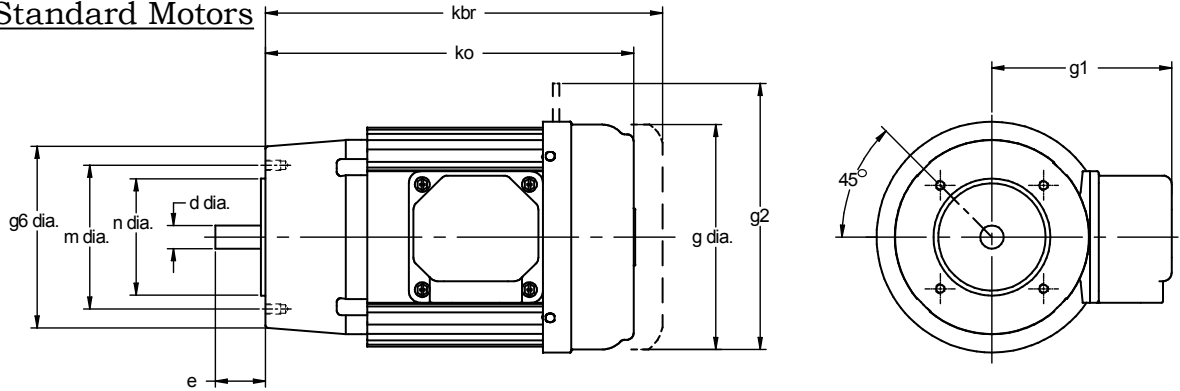

Motor Frame Size	g6 dia.	m dia.	n dia.	d dia.	e	ko	kbr	g dia.	g1	g2	Fixing Bolts	Approx Weight (lbs)
71	4.13	3.35	2.76	0.55	1.18	8.68	10.43	5.43	4.49	6.57	4xM6	14.5
80A	4.72	3.94	3.15	0.75	1.57	9.39	11.46	6.18	4.90	7.48	4xM6	21
80B	4.72	3.94	3.15	0.75	1.57	9.74	11.81	6.18	4.90	7.48	4xM6	24.5
90S	5.51	4.53	3.74	0.94	1.97	10.24	12.28	6.97	5.24	8.58	4xM8	30
90L	5.51	4.53	3.74	0.94	1.97	10.83	12.87	6.97	5.24	8.58	4xM8	32
90LA	5.51	4.53	3.74	0.94	1.97	11.18	13.23	6.97	5.24	8.58	4xM8	44
100L	6.30	5.12	4.33	1.10	2.36	12.20	14.57	7.76	5.67	9.37	4xM8	53
112M	6.30	5.12	4.33	1.10	2.36	12.80	15.71	8.62	6.10	9.37	4xM8	68.5
112MA	6.30	5.12	4.33	1.10	2.36	13.54	16.50	8.62	6.10	9.37	4xM8	99
132SA	7.87	6.50	5.12	1.50	3.15	15.43	18.70	9.25	6.77	11.34	4xM10	106
132M	7.87	6.50	5.12	1.50	3.15	16.22	19.49	9.25	6.77	11.34	4xM10	115
132MA	7.87	6.50	5.12	1.50	3.15	17.17	20.43	9.25	6.77	11.34	4xM10	172
132MB	7.87	6.50	5.12	1.50	3.15	18.58	21.85	9.25	6.77	11.34	4xM10	194

These dimensions apply to our standard Metric IEC motors

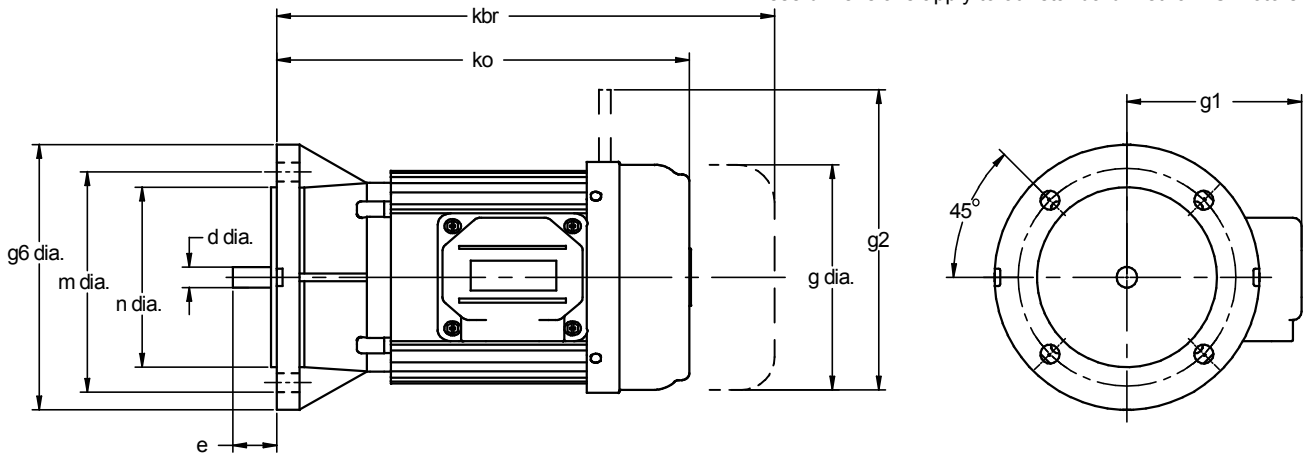

Motor Frame Size	g6 dia.	m dia.	n dia.	d dia.	e	ko	kbr	g dia.	g1	g2	Fixing Bolts	Approx Weight (lbs)
63	5.51	4.53	3.74	0.43	0.91	8.58	10.35	4.80	4.23	6.30	4xM8	10
71	6.30	5.12	4.33	0.55	1.18	8.68	10.43	5.43	4.49	6.57	4xM8	14.5
80A	7.87	6.50	5.12	0.75	1.57	9.39	11.46	6.18	4.90	7.48	4xM10	21
80B	7.87	6.50	5.12	0.75	1.57	9.74	11.81	6.18	4.90	7.48	4xM10	24.5
90S	7.87	6.50	5.12	0.94	1.97	10.24	12.28	6.97	5.24	8.58	4xM10	30
90L	7.87	6.50	5.12	0.94	1.97	10.83	12.87	6.97	5.24	8.58	4xM10	32
90LA	7.87	6.50	5.12	0.94	1.97	11.18	13.23	6.97	5.24	8.58	4xM10	44
100L	9.84	8.46	7.09	1.10	2.36	12.20	14.57	7.76	5.67	9.37	4xM12	53
112M	9.84	8.46	7.09	1.10	2.36	12.80	15.71	8.62	6.10	9.37	4xM12	68.5
112MA	9.84	8.46	7.09	1.10	2.36	13.54	16.50	8.62	6.10	9.37	4xM12	99
132SA	11.81	10.43	9.06	1.50	3.15	15.43	18.70	9.25	6.77	11.34	4xM12	106
132M	11.81	10.43	9.06	1.50	3.15	16.22	19.49	9.25	6.77	11.34	4xM12	115
132MA	11.81	10.43	9.06	1.50	3.15	17.17	20.43	9.25	6.77	11.34	4xM12	172
132MB	11.81	10.43	9.06	1.50	3.15	18.58	21.85	9.25	6.77	11.34	4xM12	194

These dimensions apply to our standard Metric IEC motors

# Series B

# Motor Details - NEMA Standard Motors

## NEMA Standard Motors

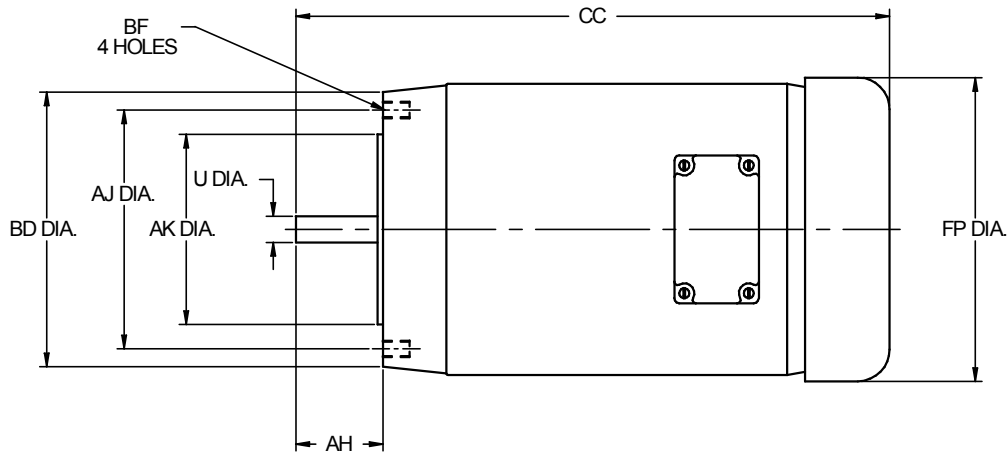

MOTOR FRAME SIZE	BD dia.	AJ dia.	AK dia.	U dia.	AH	CC max	FP dia.	BF TAP UNC	Approx Weight (lbs)
56C	6.50	5.88	4.5	0.625	2.06	14.06	7.19	0.38	25
143TC	6.50	5.88	4.5	0.875	2.13	14.19	7.19	0.38	30
145TC	6.50	5.88	4.5	0.875	2.13	14.19	7.19	0.38	40

These dimensions apply to our standard NEMA Motors

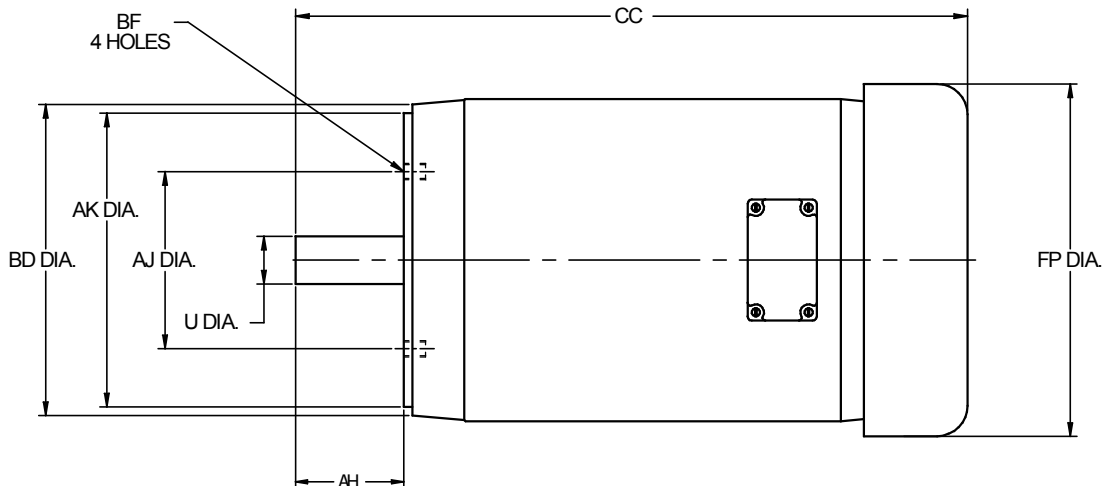

MOTOR FRAME SIZE	BD dia.	AJ dia.	AK dia.	U dia.	AH	CC max	FP dia.	BF TAP UNC	Approx Weight (lbs)
182TC	9.00	7.25	8.5	1.125	2.63	18.06	8.50	0.50	55
184TC	9.00	7.25	8.5	1.125	2.63	18.06	8.50	0.50	77
213TC	9.00	7.25	8.5	1.375	3.13	19.44	10.19	0.50	116
215TC	9.00	7.25	8.5	1.375	3.13	19.44	10.19	0.50	157

These dimensions apply to our standard NEMA Motors

# Series B

# Motorized Selection Tables

**0.25 HP**

4 POLE  
1750 RPM

						MOTOR FRAME	
OUTPUT SPEED	RATIO	OUTPUT TORQUE (LB-IN)	MECH S.F.	OHL(LB)	UNIT DESIGNATION	NEMA	IEC
350	5	39	7.04	400	B 0 2 1 0 5 . 0 _ M _ _ _ . 2 5 B _ _	56C	63
233	7.5	57	5.21	400	7 . 5		
175	10	73	4.20	400	1 0 .		
117	15	103	3.15	400	1 5 .		
88	20	128	2.50	400	2 0 .		
70	25	151	2.25	400	2 5 .		
58	30	171	1.94	400	3 0 .		
44	40	197	1.51	400	4 0 .		
35	50	220	1.33	400	5 0 .		
29	60	234	1.16	400	6 0 .		
58	30	184	2.68	475	B 0 3 1 0 3 0 . _ M _ _ _ . 2 5 B _ _	56C	63
44	40	217	2.05	475	4 0 .		
35	50	244	1.77	475	5 0 .		
29	60	263	1.53	475	6 0 .		
44	40	231	2.72	710	B 0 4 1 0 4 0 . _ M _ _ _ . 2 5 B _ _	56C	63
35	50	263	2.32	710	5 0 .		
29	60	287	1.99	710	6 0 .		
35	50	278	2.99	975	B 0 5 1 0 5 0 . _ M _ _ _ . 2 5 B _ _	56C	63
29	60	306	2.56	975	6 0 .		
18	100	603	2.37	975	B 0 5 2 0 1 0 0 _ M _ _ _ . 2 5 B _ _	56C	63
12	150	840	1.84	975	1 5 0		
8.8	200	1065	1.45	975	2 0 0		
5.8	300	1447	1.07	975	3 0 0		
4.4	400	1751	0.88	975	4 0 0		
12	150	861	3.02	1100	B 0 6 2 0 1 5 0 _ M _ _ _ . 2 5 B _ _	56C	63
8.8	200	1092	2.38	1100	2 0 0		
5.8	300	1485	1.75	1100	3 0 0		
4.4	400	1795	1.45	1100	4 0 0		
3.5	500	2152	1.21	1100	5 0 0		
2.9	600	2358	1.10	1100	6 0 0		
2.2	800	2695	0.96	1100	8 0 0		
1.8	1000	2981	0.87	1100	1 0 0 0		
1.5	1200	3159	0.82	1100	1 2 0 0		
8.8	200	1164	2.92	1200	B 0 8 2 0 2 0 0 _ M _ _ _ . 2 5 B _ _	56C	63
5.8	300	1610	2.11	1200	3 0 0		
4.4	400	1991	1.70	1200	4 0 0		
3.5	500	2403	1.41	1200	5 0 0		
2.9	600	2668	1.27	1200	6 0 0		
2.2	800	3140	1.08	1200	8 0 0		
1.8	1000	3544	0.96	1200	1 0 0 0		
1.5	1200	3819	0.89	1200	1 2 0 0		
5.8	300	1637	2.97	1550	B 0 9 2 0 3 0 0 _ M _ _ _ . 2 5 B _ _	56C	63
4.4	400	2022	2.41	1550	4 0 0		
3.5	500	2441	1.99	1550	5 0 0		
2.9	600	2711	1.80	1550	6 0 0		
2.2	800	3187	1.53	1550	8 0 0		
1.8	1000	3592	1.36	1550	1 0 0 0		
1.5	1200	3872	1.26	1550	1 2 0 0		
1.2	1500	4606	0.84	1550	1 5 0 0		
1.0	1800	5014	0.77	1550	1 8 0 0		
4.4	400	2094	2.87	2000	B 1 0 2 0 4 0 0 _ M _ _ _ . 2 5 B _ _	56C	63
3.5	500	2531	2.37	2000	5 0 0		
2.9	600	2827	2.12	2000	6 0 0		
2.2	800	3362	1.79	2000	8 0 0		
1.8	1000	3825	1.57	2000	1 0 0 0		
1.5	1200	4151	1.45	2000	1 2 0 0		
1.2	1500	4819	0.99	2000	1 5 0 0		
1.0	1800	5281	0.90	2000	1 8 0 0		
0.73	2400	6166	0.77	2000	2 4 0 0		
0.58	3000	6939	0.69	2000	3 0 0 0		

**NOTE**

Other output speeds are available using 2 and 6 pole motors - Consult our Application Engineers

Ratings assumes units are fitted with standard output shafts.

# Series B

# Motorized Selection Tables

**0.33 HP**

4 POLE  
1750 RPM

OUTPUT SPEED	RATIO	OUTPUT TORQUE (LB-IN)	MECH S.F.	OHL(LB)	UNIT DESIGNATION	MOTOR FRAME	
						NEMA	IEC
350	5	52	5.33	400	B 0 2 1 0 5 . 0 _ M _ _ _ . 3 3 B _ _	56C	63
233	7.5	75	3.95	400	7 . 5		
175	10	97	3.18	400	1 0 .		
117	15	136	2.38	400	1 5 .		
88	20	169	1.89	400	2 0 .		
70	25	199	1.71	400	2 5 .		
58	30	226	1.47	400	3 0 .		
44	40	260	1.14	400	4 0 .		
35	50	290	1.00	400	5 0 .		
29	60	308	0.88	400	6 0 .		
88	20	178	2.66	475	B 0 3 1 0 2 0 . _ M _ _ _ . 3 3 B _ _	56C	71
70	25	213	2.40	475	2 5 .		
58	30	243	2.03	475	3 0 .		
44	40	286	1.55	475	4 0 .		
35	50	323	1.34	475	5 0 .		
29	60	348	1.16	475	6 0 .		
58	30	255	2.74	710	B 0 4 1 0 3 0 . _ M _ _ _ . 3 3 B _ _	56C	71
44	40	305	2.06	710	4 0 .		
35	50	347	1.76	710	5 0 .		
29	60	379	1.51	710	6 0 .		
44	40	320	2.70	975	B 0 5 1 0 4 0 . _ M _ _ _ . 3 3 B _ _	56C	71
35	50	367	2.27	975	5 0 .		
29	60	404	1.94	975	6 0 .		
18	100	796	1.80	975	B 0 5 2 0 1 0 0 _ M _ _ _ . 3 3 B _ _	56C	71
12	150	1108	1.40	975	1 5 0		
8.8	200	1406	1.10	975	2 0 0		
5.8	300	1910	0.81	975	3 0 0		
29	60	438	2.98	1100	B 0 6 1 0 6 0 . _ M _ _ _ . 3 3 B _ _	56C	71
18	100	807	2.98	1100	B 0 6 2 0 1 0 0 _ M _ _ _ . 3 3 B _ _	56C	71
12	150	1137	2.29	1100	1 5 0		
8.8	200	1441	1.80	1100	2 0 0		
5.8	300	1960	1.33	1100	3 0 0		
4.4	400	2370	1.10	1100	4 0 0		
3.5	500	2841	0.91	1100	5 0 0		
2.9	600	3113	0.83	1100	6 0 0		
12	150	1202	2.82	1200	B 0 8 2 0 1 5 0 _ M _ _ _ . 3 3 B _ _	56C	71
8.8	200	1536	2.21	1200	2 0 0		
5.8	300	2126	1.60	1200	3 0 0		
4.4	400	2629	1.29	1200	4 0 0		
3.5	500	3172	1.07	1200	5 0 0		
2.9	600	3521	0.96	1200	6 0 0		
2.2	800	4145	0.82	1200	8 0 0		
8.8	200	1561	3.12	1550	B 0 9 2 0 2 0 0 _ M _ _ _ . 3 3 B _ _	56C	71
5.8	300	2161	2.25	1550	3 0 0		
4.4	400	2670	1.82	1550	4 0 0		
3.5	500	3222	1.51	1550	5 0 0		
2.9	600	3578	1.36	1550	6 0 0		
2.2	800	4207	1.16	1550	8 0 0		
1.8	1000	4742	1.03	1550	1 0 0 0		
1.5	1200	5111	0.95	1550	1 2 0 0		
5.8	300	2225	2.70	2000	B 1 0 2 0 3 0 0 _ M _ _ _ . 3 3 B _ _	56C	71
4.4	400	2764	2.17	2000	4 0 0		
3.5	500	3340	1.80	2000	5 0 0		
2.9	600	3732	1.61	2000	6 0 0		
2.2	800	4437	1.35	2000	8 0 0		
1.8	1000	5048	1.19	2000	1 0 0 0		
1.5	1200	5480	1.10	2000	1 2 0 0		
1.2	1500	6362	0.75	2000	1 5 0 0		
4.4	400	2790	2.70	2200	B 1 1 2 0 4 0 0 _ M _ _ _ . 3 3 B _ _	56C	71
3.5	500	3373	2.24	2200	5 0 0		
2.9	600	3764	2.00	2200	6 0 0		
2.2	800	4489	1.68	2200	8 0 0		
1.8	1000	5063	1.49	2200	1 0 0 0		
1.5	1200	5530	1.36	2200	1 2 0 0		
1.2	1500	6488	0.92	2200	1 5 0 0		
1.0	1800	7100	0.84	2200	1 8 0 0		
0.73	2400	8315	0.72	2200	2 4 0 0		

**NOTE**

Other output speeds are available using 2 and 6 pole motors - Consult our Application Engineers

Ratings assumes units are fitted with standard output shafts.

# Series B

# Motorized Selection Tables

**0.50 HP**

4 POLE  
1750 RPM

OUTPUT SPEED	RATIO	OUTPUT TORQUE (LB-IN)	MECH S.F.	OHL(LB)	UNIT DESIGNATION	MOTOR FRAME	
						NEMA	IEC
350	5	78	3.52	400	B 0 2 1 0 5 . 0 _ M _ _ _ . 5 0 B _ _	56C	71
233	7.5	113	2.60	400	7 . 5		
175	10	147	2.10	400	1 0 .		
117	15	206	1.57	400	1 5 .		
88	20	255	1.25	400	2 0 .		
70	25	302	1.13	400	2 5 .		
58	30	342	0.97	400	3 0 .		
44	40	395	0.75	400	4 0 .		
175	10	152	2.94	475	B 0 3 1 0 1 0 . _ M _ _ _ . 5 0 B _ _	56C	71
117	15	216	2.22	475	1 5 .		
88	20	270	1.76	475	2 0 .		
70	25	322	1.58	475	2 5 .		
58	30	368	1.34	475	3 0 .		
44	40	433	1.02	475	4 0 .		
35	50	489	0.89	475	5 0 .		
29	60	527	0.77	475	6 0 .		
117	15	223	3.03	710	B 0 4 1 0 1 5 . _ M _ _ _ . 5 0 B _ _	56C	71
88	20	281	2.40	710	2 0 .		
70	25	337	2.16	710	2 5 .		
58	30	387	1.81	710	3 0 .		
44	40	462	1.36	710	4 0 .		
35	50	526	1.16	710	5 0 .		
29	60	574	0.99	710	6 0 .		
88	20	289	3.21	975	B 0 5 1 0 2 0 . _ M _ _ _ . 5 0 B _ _	56C	71
70	25	348	2.88	975	2 5 .		
58	30	402	2.39	975	3 0 .		
44	40	485	1.78	975	4 0 .		
35	50	556	1.50	975	5 0 .		
29	60	612	1.28	975	6 0 .		
18	100	1207	1.18	975	B 0 5 2 0 1 0 0 _ M _ _ _ . 5 0 B _ _	56C	71
12	150	1679	0.92	975	1 5 0 .		
44	40	515	2.81	1100	B 0 6 1 0 4 0 . _ M _ _ _ . 5 0 B _ _	56C	71
35	50	597	2.32	1100	5 0 .		
29	60	664	1.96	1100	6 0 .		
18	100	1222	1.96	1100	B 0 6 2 0 1 0 0 _ M _ _ _ . 5 0 B _ _	56C	71
12	150	1723	1.51	1100	1 5 0		
8.8	200	2184	1.19	1100	2 0 0		
5.8	300	2970	0.88	1100	3 0 0		
35	50	614	2.92	1200	B 0 8 1 0 5 0 . _ M _ _ _ . 5 0 B _ _	56C	71
29	60	687	2.47	1200	6 0 .		
18	100	1280	2.45	1200	B 0 8 2 0 1 0 0 _ M _ _ _ . 5 0 B _ _	56C	71
12	150	1822	1.86	1200	1 5 0		
8.8	200	2327	1.46	1200	2 0 0		
5.8	300	3221	1.05	1200	3 0 0		
4.4	400	3983	0.85	1200	4 0 0		
18	100	1299	3.46	1550	B 0 9 2 0 1 0 0 _ M _ _ _ . 5 0 B _ _	56C	71
12	150	1848	2.64	1550	1 5 0		
8.8	200	2365	2.06	1550	2 0 0		
5.8	300	3275	1.49	1550	3 0 0		
4.4	400	4045	1.20	1550	4 0 0		
3.5	500	4882	1.00	1550	5 0 0		
2.9	600	5422	0.90	1550	6 0 0		
12	150	1889	3.18	2000	B 1 0 2 0 1 5 0 _ M _ _ _ . 5 0 B _ _	56C	71
8.8	200	2420	2.48	2000	2 0 0		
5.8	300	3371	1.78	2000	3 0 0		
4.4	400	4187	1.43	2000	4 0 0		
3.5	500	5061	1.19	2000	5 0 0		
2.9	600	5655	1.06	2000	6 0 0		
2.2	800	6723	0.89	2000	8 0 0		
8.8	200	2442	3.09	2200	B 1 1 2 0 2 0 0 _ M _ _ _ . 5 0 B _ _	56C	71
5.8	300	3403	2.22	2200	3 0 0		
4.4	400	4228	1.78	2200	4 0 0		
3.5	500	5111	1.48	2200	5 0 0		
2.9	600	5703	1.32	2200	6 0 0		
2.2	800	6802	1.11	2200	8 0 0		
1.8	1000	7672	0.98	2200	1 0 0 0		
1.5	1200	8378	0.90	2200	1 2 0 0		

**NOTE**

Other output speeds are available using 2 and 6 pole motors - Consult our

Application Engineers

Ratings assumes units are fitted with standard output shafts.

## 0.75 HP

4 POLE  
1750 RPM

OUTPUT SPEED	RATIO	OUTPUT TORQUE (LB-IN)	MECH S.F.	OHL(LB)	UNIT DESIGNATION	MOTOR FRAME	
						NEMA	IEC
350	5	117	2.35	400	B 0 2 1 0 5 . 0 _ M _ . 7 5 B _ _	56C	80
233	7.5	170	1.74	400	7.5		
175	10	220	1.40	400	10.		
117	15	310	1.05	400	15.		
88	20	383	0.83	400	20.		
70	25	453	0.75	400	25.		
350	5	120	3.35	475	B 0 3 1 0 5 . 0 _ M _ . 7 5 B _ _	56C	80
233	7.5	175	2.47	475	7.5		
175	10	228	1.96	475	10.		
117	15	324	1.48	475	15.		
88	20	406	1.17	475	20.		
70	25	483	1.05	475	25.		
58	30	552	0.89	475	30.		
233	7.5	178	3.38	710	B 0 4 1 0 7 . 5 _ M _ . 7 5 B _ _	56C	80
175	10	233	2.45	710	10.		
117	15	334	2.02	710	15.		
88	20	422	1.60	710	20.		
70	25	505	1.44	710	25.		
58	30	581	1.20	710	30.		
44	40	694	0.91	710	40.		
35	50	789	0.77	710	50.		
117	15	341	2.69	975	B 0 5 1 0 1 5 . _ M _ . 7 5 B _ _	56C	80
88	20	434	2.14	975	20.		
70	25	522	1.92	975	25.		
58	30	602	1.60	975	30.		
44	40	728	1.19	975	40.		
35	50	834	1.00	975	50.		
29	60	918	0.85	975	60.		
58	30	631	2.55	1100	B 0 6 1 0 3 0 . _ M _ . 7 5 B _ _	56C	80
44	40	773	1.88	1100	40.		
35	50	895	1.54	1100	50.		
29	60	996	1.31	1100	60.		
18	100	1834	1.31	1100	B 0 6 2 0 1 0 0 _ M _ . 7 5 B _ _	56C	80
12	150	2584	1.01	1100	150		
44	40	792	2.39	1200	B 0 8 1 0 4 0 . _ M _ . 7 5 B _ _	56C	80
35	50	921	1.95	1200	50.		
29	60	1031	1.65	1200	60.		
18	100	1919	1.63	1200	B 0 8 2 0 1 0 0 _ M _ . 7 5 B _ _	56C	80
12	150	2732	1.24	1200	150		
8.8	200	3491	0.97	1200	200		
35	50	952	2.68	1550	B 0 9 1 0 5 0 . _ M _ . 7 5 B _ _	56C	80
29	60	1071	2.26	1550	60.		
18	100	1949	2.31	1550	B 0 9 2 0 1 0 0 _ M _ . 7 5 B _ _	56C	80
12	150	2772	1.76	1550	150		
8.8	200	3547	1.37	1550	200		
5.8	300	4912	0.99	1550	300		
29	60	1092	2.73	2000	B 1 0 1 0 6 0 . _ M _ . 7 5 B _ _	56C	80
18	100	1984	2.79	2000	B 1 0 2 0 1 0 0 _ M _ . 7 5 B _ _	56C	80
12	150	2834	2.12	2000	150		
8.8	200	3630	1.65	2000	200		
5.8	300	5057	1.19	2000	300		
4.4	400	6281	0.96	2200	400		
18	100	2001	3.48	2200	B 1 1 2 0 1 0 0 _ M _ . 7 5 B _ _	56C	80
12	150	2859	2.64	2200	150		
8.8	200	3663	2.06	2200	200		
5.8	300	5105	1.48	2200	300		
4.4	400	6342	1.19	2200	400		
3.5	500	7666	0.98	2200	500		
2.9	600	8555	0.88	2200	600		

### NOTE

Other output speeds are available using 2 and 6 pole motors - Consult our Application Engineers

Ratings assumes units are fitted with standard output shafts.

# Series B

# Motorized Selection Tables

**1.0 HP**

4 POLE  
1750 RPM

						MOTOR FRAME	
OUTPUT SPEED	RATIO	OUTPUT TORQUE (LB-IN)	MECH S.F.	OHL(LB)	UNIT DESIGNATION	NEMA	IEC
350	5	156	1.76	400	B 0 2 1 0 5 . 0 _ M _ _ _ _ 1.0 B _ _	143TC	80
233	7.5	227	1.30	400	7.5		
175	10	294	1.05	400	10.		
117	15	413	0.79	400	15.		
350	5	160	2.51	475	B 0 3 1 0 5 . 0 _ M _ _ _ _ 1.0 B _ _	143TC	80
233	7.5	233	1.85	475	7.5		
175	10	304	1.47	475	10.		
117	15	432	1.11	475	15.		
88	20	541	0.88	475	20.		
70	25	645	0.79	475	25.		
350	5	162	3.45	710	B 0 4 1 0 5 . 0 _ M _ _ _ _ 1.0 B _ _	143TC	80
233	7.5	238	2.54	710	7.5		
175	10	310	1.84	710	10.		
117	15	445	1.51	710	15.		
88	20	562	1.20	710	20.		
70	25	674	1.08	710	25.		
58	30	774	0.90	710	30.		
44	40	925	0.68	710	40.		
233	7.5	241	3.39	975	B 0 5 1 0 7 . 5 _ M _ _ _ _ 1.0 B _ _	143TC	80
175	10	316	2.63	975	10.		
117	15	455	2.02	975	15.		
88	20	578	1.60	975	20.		
70	25	696	1.44	975	25.		
58	30	803	1.20	975	30.		
44	40	970	0.89	975	40.		
117	15	468	3.26	1100	B 0 6 1 0 1 5 . _ M _ _ _ _ 1.0 B _ _	143TC	80
88	20	599	2.59	1100	20.		
70	25	724	2.32	1100	25.		
58	30	841	1.91	1100	30.		
44	40	1031	1.41	1100	40.		
35	50	1193	1.16	1100	50.		
29	60	1328	0.98	1100	60.		
18	100	2445	0.98	1100	B 0 6 2 0 1 0 0 _ M _ _ _ _ 1.0 B _ _	143TC	80
70	25	730	2.72	1200	B 0 8 1 0 2 5 . _ M _ _ _ _ 1.0 B _ _	143TC	80
58	30	857	2.45	1200	30.		
44	40	1056	1.79	1200	40.		
35	50	1228	1.46	1200	50.		
29	60	1374	1.24	1200	60.		
18	100	2559	1.23	1200	B 0 8 2 0 1 0 0 _ M _ _ _ _ 1.0 B _ _	143TC	80
12	150	3643	0.93	1200	150		
44	40	1086	2.49	1550	B 0 9 1 0 4 0 . _ M _ _ _ _ 1.0 B _ _	143TC	80
35	50	1269	2.01	1550	50.		
29	60	1428	1.70	1550	60.		
18	100	2598	1.73	1550	B 0 9 2 0 1 0 0 _ M _ _ _ _ 1.0 B _ _	143TC	80
12	150	3696	1.32	1550	150		
8.8	200	4729	1.03	1550	200		
35	50	1291	2.43	2000	B 1 0 1 0 5 0 . _ M _ _ _ _ 1.0 B _ _	143TC	80
29	60	1456	2.05	2000	60.		
18	100	2645	2.10	2000	B 1 0 2 0 1 0 0 _ M _ _ _ _ 1.0 B _ _	143TC	80
12	150	3778	1.59	2000	150		
8.8	200	4840	1.24	2000	200		
5.8	300	6742	0.89	2000	300		
35	50	1312	2.99	2200	B 1 1 1 0 5 0 . _ M _ _ _ _ 1.0 B _ _	143TC	80
29	60	1484	2.52	2200	60.		
18	100	2668	2.61	2200	B 1 1 2 0 1 0 0 _ M _ _ _ _ 1.0 B _ _	143TC	80
12	150	3812	1.98	2200	150		
8.8	200	4885	1.54	2200	200		
5.8	300	6806	1.11	2200	300		
4.4	400	8456	0.89	2200	400		

**NOTE**

Other output speeds are available using 2 and 6 pole motors - Consult our Application Engineers

Ratings assumes units are fitted with standard output shafts.

# Series B

# Motorized Selection Tables

**1.5 HP**

4 POLE  
1750 RPM

OUTPUT SPEED	RATIO	OUTPUT TORQUE (LB-IN)	MECH S.F.	OHL(LB)	UNIT DESIGNATION	MOTOR FRAME	
						NEMA	IEC
350	5	234	1.17	400	B 0 2 1 0 5 . 0 _ M _ _ _ _ 1.5 B _ _	145TC	90
233	7.5	340	0.87	400	7.5		
175	10	441	0.70	400	10.		
350	5	239	1.68	475	B 0 3 1 0 5 . 0 _ M _ _ _ _ 1.5 B _ _	145TC	90
233	7.5	350	1.24	475	7.5		
175	10	455	0.98	475	10.		
117	15	648	0.74	475	15.		
350	5	243	2.30	710	B 0 4 1 0 5 . 0 _ M _ _ _ _ 1.5 B _ _	145TC	90
233	7.5	357	1.69	710	7.5		
175	10	466	1.22	710	10.		
117	15	668	1.01	710	15.		
88	20	843	0.80	710	20.		
70	25	1010	0.72	710	25.		
350	5	246	3.08	975	B 0 5 1 0 5 . 0 _ M _ _ _ _ 1.5 B _ _	145TC	90
233	7.5	362	2.26	975	7.5		
175	10	473	1.75	975	10.		
117	15	683	1.35	975	15.		
88	20	867	1.07	975	20.		
70	25	1043	0.96	975	25.		
58	30	1205	0.80	975	30.		
233	7.5	368	3.63	1100	B 0 6 1 0 7 . 5 _ M _ _ _ _ 1.5 B _ _	145TC	90
175	10	483	2.78	1100	10.		
117	15	702	2.17	1100	15.		
88	20	898	1.73	1100	20.		
70	25	1086	1.55	1100	25.		
58	30	1262	1.28	1100	30.		
44	40	1546	0.94	1100	40.		
117	15	710	2.75	1200	B 0 8 1 0 1 5 . _ M _ _ _ _ 1.5 B _ _	145TC	90
88	20	911	2.22	1200	20.		
70	25	1095	1.82	1200	25.		
58	30	1286	1.63	1200	30.		
44	40	1585	1.19	1200	40.		
35	50	1842	0.97	1200	50.		
29	60	2061	0.82	1200	60.		
18	100	3839	0.82	1200	B 0 8 2 0 1 0 0 _ M _ _ _ _ 1.5 B _ _	145TC	90
88	20	925	3.13	1550	B 0 9 1 0 2 0 . _ M _ _ _ _ 1.5 B _ _	145TC	90
70	25	1116	2.54	1550	25.		
58	30	1313	2.29	1550	30.		
44	40	1629	1.66	1550	40.		
35	50	1904	1.34	1550	50.		
29	60	2143	1.13	1550	60.		
18	100	3897	1.15	1550	B 0 9 2 0 1 0 0 _ M _ _ _ _ 1.5 B _ _	145TC	90
12	150	5544	0.88	1550	150		
70	25	1127	3.10	2000	B 1 0 1 0 2 5 . _ M _ _ _ _ 1.5 B _ _	145TC	90
58	30	1327	2.79	2000	30.		
44	40	1652	2.02	2000	40.		
35	50	1936	1.62	2000	50.		
29	60	2185	1.37	2000	60.		
18	100	3968	1.40	2000	B 1 0 2 0 1 0 0 _ M _ _ _ _ 1.5 B _ _	145TC	90
12	150	5668	1.06	2000	150		
8.8	200	7261	0.83	2000	200		
58	30	1341	3.46	2200	B 1 1 1 0 3 0 . _ M _ _ _ _ 1.5 B _ _	145TC	90
44	40	1674	2.50	2200	40.		
35	50	1967	1.99	2200	50.		
29	60	2226	1.68	2200	60.		
18	100	4002	1.74	2200	B 1 1 2 0 1 0 0 _ M _ _ _ _ 1.5 B _ _	145TC	90
12	150	5718	1.32	2200	150		
8.8	200	7327	1.03	2200	200		

**NOTE**  
Other output speeds are available using 2 and 6 pole motors - Consult our Application Engineers  
Ratings assumes units are fitted with standard output shafts.

# Series B

# Motorized Selection Tables

**2.0 HP**

4 POLE  
1750 RPM

OUTPUT SPEED	RATIO	OUTPUT TORQUE (LB-IN)	MECH S.F.	OHL(LB)	UNIT DESIGNATION	MOTOR FRAME	
						NEMA	IEC
350	5	312	0.88	400	B 0 2 1 0 5 . 0 _ M _ _ _ _ 2 . 0 B _ _	145TC	90
350	5	319	1.26	475	B 0 3 1 0 5 . 0 _ M _ _ _ _ 2 . 0 B _ _	145TC	90
233	7.5	467	0.93	475			
175	10	607	0.74	475			
350	5	324	1.72	710	B 0 4 1 0 5 . 0 _ M _ _ _ _ 2 . 0 B _ _	145TC	90
233	7.5	476	1.27	710			
175	10	621	0.92	710			
117	15	890	0.76	710			
350	5	328	2.31	975	B 0 5 1 0 5 . 0 _ M _ _ _ _ 2 . 0 B _ _	145TC	90
233	7.5	482	1.70	975			
175	10	631	1.31	975			
117	15	910	1.01	975			
88	20	1157	0.80	975			
350	5	332	3.74	1100	B 0 6 1 0 5 . 0 _ M _ _ _ _ 2 . 0 B _ _	145TC	90
233	7.5	491	2.72	1100			
175	10	644	2.08	1100			
117	15	936	1.63	1100			
88	20	1198	1.30	1100			
70	25	1447	1.16	1100			
58	30	1682	0.96	1100			
175	10	650	2.49	1200	B 0 8 1 0 1 0 . _ M _ _ _ _ 2 . 0 B _ _	145TC	90
117	15	946	2.06	1200			
88	20	1215	1.67	1200			
70	25	1460	1.36	1200			
58	30	1714	1.22	1200			
44	40	2113	0.90	1200			
175	10	656	3.50	1550	B 0 9 1 0 1 0 . _ M _ _ _ _ 2 . 0 B _ _	145TC	90
117	15	958	2.89	1550			
88	20	1234	2.35	1550			
70	25	1488	1.91	1550			
58	30	1751	1.72	1550			
44	40	2172	1.25	1550			
35	50	2539	1.01	1550			
18	100	5196	0.87	1550	B 0 9 2 0 1 0 0 _ M _ _ _ _ 2 . 0 B _ _	145TC	90
88	20	1244	2.87	2000	B 1 0 1 0 2 0 . _ M _ _ _ _ 2 . 0 B _ _	145TC	90
70	25	1502	2.32	2000			
58	30	1769	2.09	2000			
44	40	2203	1.51	2000			
35	50	2581	1.22	2000			
29	60	2913	1.02	2000			
18	100	5290	1.05	2000	B 1 0 2 0 1 0 0 _ M _ _ _ _ 2 . 0 B _ _	145TC	90
12	150	7557	0.79	2000			
70	25	1516	2.88	2000	B 1 1 1 0 2 5 . _ M _ _ _ _ 2 . 0 B _ _	145TC	90
58	30	1787	2.60	2000			
44	40	2233	1.87	2000			
35	50	2623	1.49	2000			
29	60	2968	1.26	2000			
18	100	5336	1.30	2200	B 1 1 2 1 0 0 _ M _ _ _ _ 2 . 0 B _ _	145TC	90
12	150	7624	0.99	2200			
8.8	200	9769	0.77	2200			

**NOTE**

Other output speeds are available using 2 and 6 pole motors - Consult our Application Engineers

Ratings assumes units are fitted with standard output shafts.

# Series B

# Motorized Selection Tables

**3.0 HP**

4 POLE  
1750 RPM

**NOTE**  
Other output speeds are available using 2 and 6 pole motors - Consult our Application Engineers  
Ratings assumes units are fitted with standard output shafts.

OUTPUT SPEED	RATIO	OUTPUT TORQUE (LB-IN)	MECH S.F.	OHL(LB)	UNIT DESIGNATION	MOTOR FRAME	
						NEMA	IEC
350	5	486	1.15	710	B 0 4 1 0 5 . 0 _ M _ _ _ _ 3 . 0 B _ _	182TC	100
233	7.5	713	0.85	710	7 . 5		
350	5	491	1.54	975	B 0 5 1 0 5 . 0 _ M _ _ _ _ 3 . 0 B _ _	182TC	100
233	7.5	723	1.13	975	7 . 5		
175	10	947	0.88	975	1 0 .		
350	5	499	2.49	1100	B 0 6 1 0 5 . 0 _ M _ _ _ _ 3 . 0 B _ _	182TC	100
233	7.5	736	1.82	1100	7 . 5		
175	10	967	1.39	1100	1 0 .		
117	15	1403	1.09	1100	1 5 .		
88	20	1797	0.86	1100	2 0 .		
350	5	501	3.21	1200	B 0 8 1 0 5 . 0 _ M _ _ _ _ 3 . 0 B _ _	182TC	100
233	7.5	741	2.32	1200	7 . 5		
175	10	975	1.66	1200	1 0 .		
117	15	1419	1.38	1200	1 5 .		
88	20	1822	1.11	1200	2 0 .		
70	25	2190	0.91	1200	2 5 .		
233	7.5	748	3.25	1550	B 0 9 1 0 7 . 5 _ M _ _ _ _ 3 . 0 B _ _	182TC	100
175	10	984	2.33	1550	1 0 .		
117	15	1437	1.93	1550	1 5 .		
88	20	1851	1.57	1550	2 0 .		
70	25	2232	1.27	1550	2 5 .		
58	30	2626	1.14	1550	3 0 .		
175	10	989	2.98	2000	B 1 0 1 0 1 0 . _ M _ _ _ _ 3 . 0 B _ _	182TC	100
117	15	1446	2.39	2000	1 5 .		
88	20	1865	1.91	2000	2 0 .		
70	25	2253	1.55	2000	2 5 .		
58	30	2654	1.39	2000	3 0 .		
44	40	3304	1.01	2000	4 0 .		
117	15	1455	2.98	2200	B 1 1 1 0 1 5 . _ M _ _ _ _ 3 . 0 B _ _	182TC	100
88	20	1880	2.38	2200	2 0 .		
70	25	2274	1.92	2200	2 5 .		
58	30	2681	1.73	2200	3 0 .		
44	40	3349	1.25	2200	4 0 .		
35	50	3935	1.00	2200	5 0 .		
29	60	4453	0.84	2200	6 0 .		
18	100	8004	0.87	2200	B 1 1 2 0 1 0 0 _ M _ _ _ _ 3 . 0 B _ _	182TC	100

# Series B

# Motorized Selection Tables

## 5.0 HP

4 POLE  
1750 RPM

OUTPUT SPEED	RATIO	OUTPUT TORQUE (LB-IN)	MECH S.F.	OHL(LB)	UNIT DESIGNATION	MOTOR FRAME	
						NEMA	IEC
350	5	831	1.49	1100	B 0 6 1 0 5 . 0 _ M _ _ _ _ 5.0 B _ _	184TC	112
233	7.5	1227	1.09	1100	7.5		
175	10	1611	0.83	1100	10.		
350	5	836	1.92	1200	B 0 8 1 0 5 . 0 _ M _ _ _ _ 5.0 B _ _	184TC	112
233	7.5	1236	1.39	1200	7.5		
175	10	1625	1.00	1200	10.		
117	15	2365	0.83	1200	15.		
350	5	841	2.71	1550	B 0 9 1 0 5 . 0 _ M _ _ _ _ 5.0 B _ _	184TC	112
233	7.5	1246	1.95	1550	7.5		
175	10	1641	1.40	1550	10.		
117	15	2395	1.16	1550	15.		
350	5	844	3.32	2000	B 1 0 1 0 5 . 0 _ M _ _ _ _ 5.0 B _ _	184TC	112
233	7.5	1251	2.38	2000	7.5		
175	10	1648	1.79	2000	10.		
117	15	2410	1.44	2000	15.		
350	5	847	4.13	2200	B 1 1 1 0 5 . 0 _ M _ _ _ _ 5.0 B _ _	184TC	112
233	7.5	1256	2.95	2200	7.5		
175	10	1656	2.21	2200	10.		
117	15	2425	1.79	2200	15.		
88	20	3133	1.43	2200	20.		

## 7.5 HP

4 POLE  
1750 RPM

OUTPUT SPEED	RATIO	OUTPUT TORQUE (LB-IN)	MECH S.F.	OHL(LB)	UNIT DESIGNATION	MOTOR FRAME	
						NEMA	IEC
350	5	1254	1.28	1200	B 0 8 1 0 5 . 0 _ M _ _ _ _ 7.5 B _ _	213TC	132
233	7.5	1854	0.93	1200	7.5		
350	5	1262	1.81	1550	B 0 9 1 0 5 . 0 _ M _ _ _ _ 7.5 B _ _	213TC	132
233	7.5	1869	1.30	1550	7.5		
175	10	2461	0.93	1550	10.		
350	5	1266	2.21	2000	B 1 0 1 0 5 . 0 _ M _ _ _ _ 7.5 B _ _	213TC	132
233	7.5	1876	1.58	2000	7.5		
175	10	2473	1.19	2000	10.		
350	5	1271	2.75	2200	B 1 1 1 0 5 . 0 _ M _ _ _ _ 7.5 B _ _	213TC	132
233	7.5	1884	1.96	2200	7.5		
175	10	2485	1.47	2200	10.		

## 10.0 HP

4 POLE  
1750 RPM

OUTPUT SPEED	RATIO	OUTPUT TORQUE (LB-IN)	MECH S.F.	OHL(LB)	UNIT DESIGNATION	MOTOR FRAME	
						NEMA	IEC
350	5	1683	1.36	1550	B 0 9 1 0 5 . 0 _ M _ _ _ _ 10. B _ _	215TC	132
350	5	1689	1.66	2000	B 1 0 1 0 5 . 0 _ M _ _ _ _ 10. B _ _		
233	7.5	2502	1.19	2000	7.5	215TC	132
350	5	1694	2.06	2200	B 1 1 1 0 5 . 0 _ M _ _ _ _ 10. B _ _		
233	7.5	2512	1.47	2200	7.5		

### NOTE

Other output speeds are available using 2 and 6 pole motors - Consult our Application Engineers

Ratings assumes units are fitted with standard output shafts.



## Standard Unit

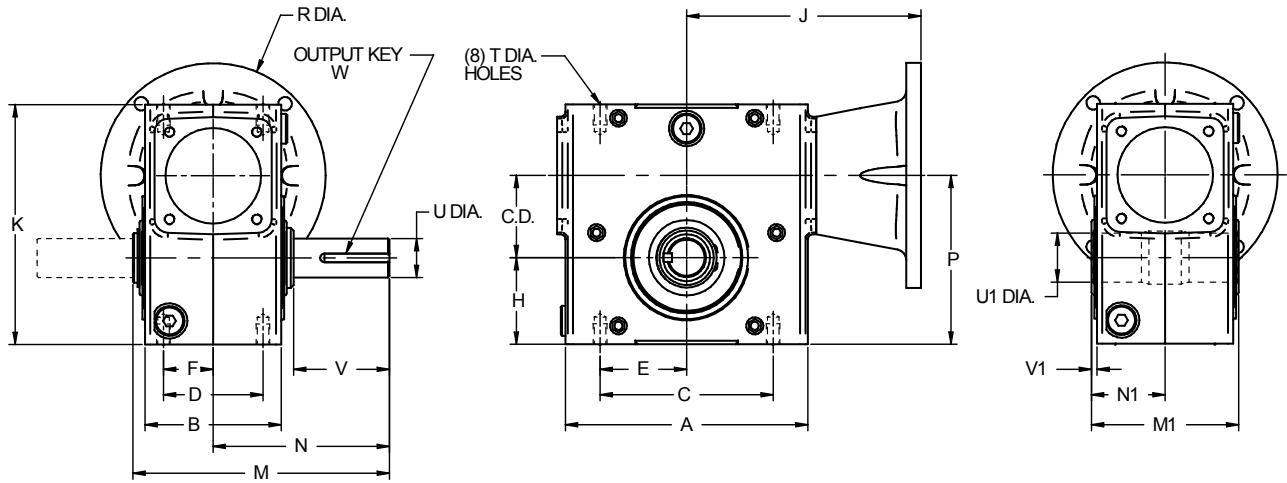

Case Size	C.D.	A	B	C	D	E	F	H	K	M	M1	N	N1	P	T Dia.
B02	1.33	4.33	2.76	3.25	2.00	1.63	1.00	1.72	4.66	6.10	3.85	4.00	1.93	3.05	M8 x 0.47
B03	1.54	5.23	3.94	4.19	2.75	2.10	1.38	1.91	5.35	6.61	4.25	4.31	2.12	3.45	M8 x 0.47
B04	1.75	5.98	3.94	4.19	2.75	2.10	1.38	2.06	5.75	6.65	4.29	4.31	2.15	3.81	M8 x 0.47
B05	1.97	6.00	3.94	5.00	2.88	2.50	1.44	2.28	6.38	7.00	4.21	4.69	2.11	4.25	M10 x 0.59
B06	2.38	7.00	3.94	5.00	2.88	2.50	1.44	2.50	6.93	7.41	4.25	5.09	2.13	4.88	M10 x 0.59
B08	2.62	7.50	5.12	6.38	3.38	3.19	1.69	2.94	7.99	8.58	5.43	5.63	2.72	5.57	M10 x 0.59
B09	3.00	9.00	5.12	7.00	4.00	3.50	2.00	3.25	8.88	9.70	5.43	6.75	2.72	6.25	M12 x 0.71
B10	3.25	9.05	5.67	7.50	4.00	3.75	2.00	3.50	9.38	10.28	5.98	7.06	2.99	6.75	M12 x 0.71
B11	3.54	9.50	5.12	7.50	4.00	3.75	2.00	3.39	9.84	11.34	6.65	7.75	3.33	6.93	M16 x 0.87

Case Size	C.D.	56C		143/145TC		182/184TC		213/215TC		OUTPUT SHAFT				W-KEY		WT (LBS)
		J	R Dia.	J	R Dia.	J	R Dia.	J	R Dia.	U Dia.	U1 Dia.	V	V1	SQ.	LG	
B02	1.33	4.74	6.5	4.74	6.5	NA	NA	NA	NA	0.750	1.000	1.88	0.12	3/16	1.00	9
B03	1.54	5.92	6.5	5.92	6.5	6.16	9.00	NA	NA	0.750	1.000	1.99	0.08	3/16	1.13	14
B04	1.75	6.18	6.5	6.18	6.5	6.42	9.00	NA	NA	1.000	1.438	1.97	0.08	1/4	1.25	16
B05	1.97	6.34	6.5	6.34	6.5	6.58	9.00	NA	NA	1.125	1.438	2.39	0.08	1/4	1.50	18
B06	2.38	6.77	6.5	6.77	6.5	7.01	9.00	NA	NA	1.125	1.438	2.77	0.08	1/4	1.88	23
B08	2.62	7.24	6.5	7.24	6.5	7.59	9.00	7.59	9.00	1.500	1.938	2.68	0.08	3/8	1.94	40
B09	3.00	7.64	6.5	7.64	6.5	7.98	9.00	7.98	9.00	1.500	2.188	3.80	0.08	3/8	2.00	47
B10	3.25	7.72	6.5	7.72	6.5	8.06	9.00	8.06	9.00	1.500	2.188	3.83	0.08	3/8	2.25	50
B11	3.54	8.15	6.5	8.15	6.5	8.50	9.00	8.50	9.00	1.875	2.938	4.15	0.10	1/2	2.63	70

NOTES: Refer to pages 13 - 14 for shaft and bore tolerances.

Refer to pages 29 - 30 for motor dimensions.

## Unit with Horizontal Base (Over Driven)

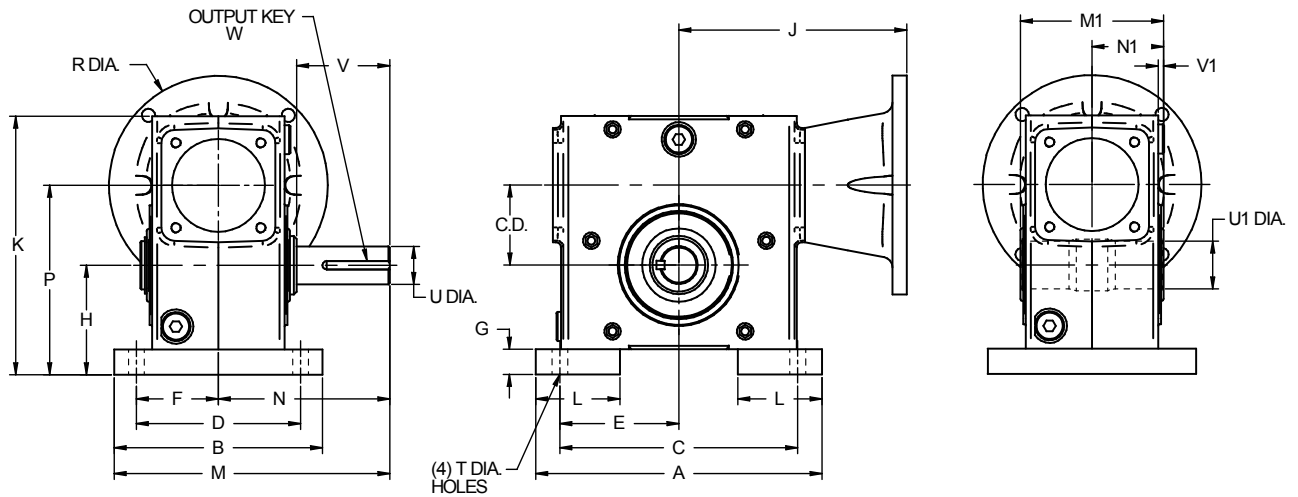

Case Size	C.D.	A	B	C	D	E	F	G	H	K	L	M	M1	N	N1	P	T Dia.
B02	1.33	5.38	4.19	4.380	3.310	2.190	1.655	0.53	2.25	5.19	1.50	6.09	3.85	4.00	1.93	3.58	11/32
B03	1.54	6.44	5.44	5.250	4.312	2.625	2.156	0.59	2.50	5.94	1.50	7.03	4.25	4.31	2.12	4.04	13/32
B04	1.75	7.00	5.69	5.750	4.500	2.875	2.250	0.69	2.75	6.44	2.00	7.16	4.29	4.31	2.15	4.50	13/32
B05	1.97	7.75	5.94	6.380	4.690	3.190	2.345	0.72	3.00	7.10	2.00	7.66	4.21	4.69	2.11	4.97	15/32
B06	2.38	8.50	6.19	7.063	4.875	3.532	2.438	0.75	3.25	7.68	2.50	8.19	4.25	5.09	2.13	5.63	15/32
B08	2.62	9.63	6.66	8.000	5.250	4.000	2.625	0.75	3.69	8.74	2.50	8.96	5.43	5.63	2.72	6.31	17/32
B09	3.00	10.00	7.50	8.440	5.880	4.220	2.940	0.75	4.00	9.63	2.00	10.50	5.43	6.75	2.72	7.00	17/32
B10	3.25	11.19	7.66	9.500	6.125	4.750	3.063	0.88	4.38	10.25	2.50	10.89	5.98	7.06	2.99	7.63	17/32
B11	3.54	11.08	7.71	9.500	6.120	4.750	3.060	1.61	5.00	11.45	2.50	11.61	6.65	7.75	3.33	8.54	9/16

Case Size	C.D.	56C		143/145TC		182/184TC		213/215TC		OUTPUT SHAFT				W-KEY		WT (LBS)
		J	R Dia.	J	R Dia.	J	R Dia.	J	R Dia.	U Dia.	U1 Dia.	V	V1	SQ.	LG	
B02	1.33	4.74	6.5	4.74	6.5	NA	NA	NA	NA	0.750	1.000	1.88	0.12	3/16	1.00	10
B03	1.54	5.92	6.5	5.92	6.5	6.16	9.00	NA	NA	0.750	1.000	1.99	0.08	3/16	1.13	15
B04	1.75	6.18	6.5	6.18	6.5	6.42	9.00	NA	NA	1.000	1.438	1.97	0.08	1/4	1.25	18
B05	1.97	6.34	6.5	6.34	6.5	6.58	9.00	NA	NA	1.125	1.438	2.39	0.08	1/4	1.50	20
B06	2.38	6.77	6.5	6.77	6.5	7.01	9.00	NA	NA	1.125	1.438	2.77	0.08	1/4	1.88	25
B08	2.62	7.24	6.5	7.24	6.5	7.59	9.00	7.59	9.00	1.500	1.938	2.68	0.08	3/8	1.97	43
B09	3.00	7.64	6.5	7.64	6.5	7.98	9.00	7.98	9.00	1.500	2.188	3.80	0.08	3/8	2.00	50
B10	3.25	7.72	6.5	7.72	6.5	8.06	9.00	8.06	9.00	1.500	2.188	3.83	0.08	3/8	2.25	54
B11	3.54	8.15	6.5	8.15	6.5	8.50	9.00	8.50	9.00	1.875	2.938	4.15	0.10	1/2	2.63	75

NOTES: Refer to pages 13 - 14 for shaft and bore tolerances.

Refer to pages 29 - 30 for motor dimensions.

## Unit with Horizontal Base (Under Driven)

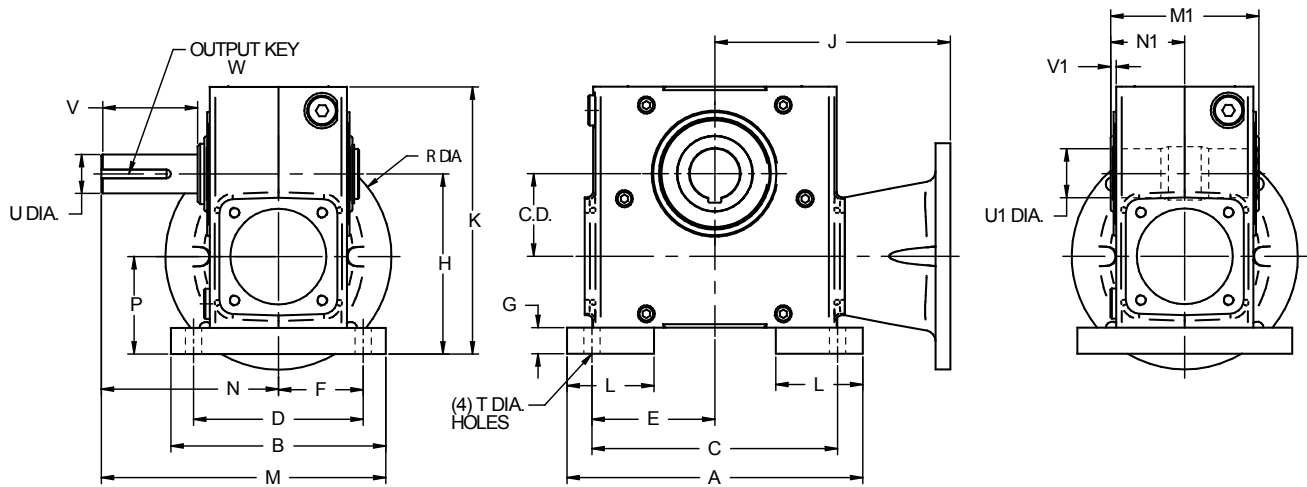

Case Size	C.D	A	B	C	D	E	F	G	H	K	L	M	M1	N	N1	P	T Dia.
B02	1.33	5.38	4.19	4.380	3.310	2.190	1.655	0.53	3.47	5.19	1.50	6.09	3.85	4.00	1.93	2.14	11/32
B03	1.54	6.44	5.44	5.250	4.312	2.625	2.156	0.59	4.03	5.94	1.50	7.03	4.25	4.31	2.12	2.49	13/32
B04	1.75	7.00	5.69	5.750	4.500	2.875	2.250	0.69	4.38	6.44	2.00	7.16	4.29	4.31	2.15	2.63	13/32
B05	1.97	7.75	5.94	6.380	4.690	3.190	2.345	0.72	4.82	7.10	2.00	7.66	4.21	4.69	2.11	2.85	15/32
B06	2.38	8.50	6.19	7.063	4.875	3.532	2.438	0.75	5.18	7.68	2.50	8.19	4.25	5.09	2.13	2.80	15/32
B08	2.62	9.63	6.66	8.000	5.250	4.000	2.625	0.75	5.80	8.74	2.50	8.96	5.43	5.63	2.72	3.18	17/32
B09	3.00	10.00	7.50	8.440	5.880	4.220	2.940	0.75	6.38	9.63	2.00	10.50	5.43	6.75	2.72	3.38	17/32
B10	3.25	11.19	7.66	9.500	6.125	4.750	3.063	0.88	6.75	10.25	2.50	10.89	5.98	7.06	2.99	3.50	17/32
B11	3.54	11.08	7.71	9.500	6.120	4.750	3.060	1.61	8.07	11.45	2.50	11.61	6.65	7.75	3.33	4.53	9/16

Case Size	C.D	56C		143/145TC		182/184TC		213/215TC		OUTPUT SHAFT				W-KEY		WT (LBS)
		J	R Dia.	J	R Dia.	J	R Dia.	J	R Dia.	U Dia.	U1 Dia.	V	V1	SQ.	LG	
B02	1.33	4.74	6.5	4.74	6.5	NA	NA	NA	NA	0.750	1.000	1.88	0.12	3/16	1.00	10
B03	1.54	5.92	6.5	5.92	6.5	6.16	9.00	NA	NA	0.750	1.000	1.99	0.08	3/16	1.13	15
B04	1.75	6.18	6.5	6.18	6.5	6.42	9.00	NA	NA	1.000	1.438	1.97	0.08	1/4	1.25	18
B05	1.97	6.34	6.5	6.34	6.5	6.58	9.00	NA	NA	1.125	1.438	2.39	0.08	1/4	1.50	20
B06	2.38	6.77	6.5	6.77	6.5	7.01	9.00	NA	NA	1.125	1.438	2.77	0.08	1/4	1.88	25
B08	2.62	7.24	6.5	7.24	6.5	7.59	9.00	7.59	9.00	1.500	1.938	2.68	0.08	3/8	1.97	43
B09	3.00	7.64	6.5	7.64	6.5	7.98	9.00	7.98	9.00	1.500	2.188	3.80	0.08	3/8	2.00	50
B10	3.25	7.72	6.5	7.72	6.5	8.06	9.00	8.06	9.00	1.500	2.188	3.83	0.08	3/8	2.25	54
B11	3.54	8.15	6.5	8.15	6.5	8.50	9.00	8.50	9.00	1.875	2.938	4.15	0.10	1/2	2.63	75

NOTES: Refer to pages 13 - 14 for shaft and bore tolerances.

Refer to pages 29 - 30 for motor dimensions.

## Unit with Vertical Base (High & Low)

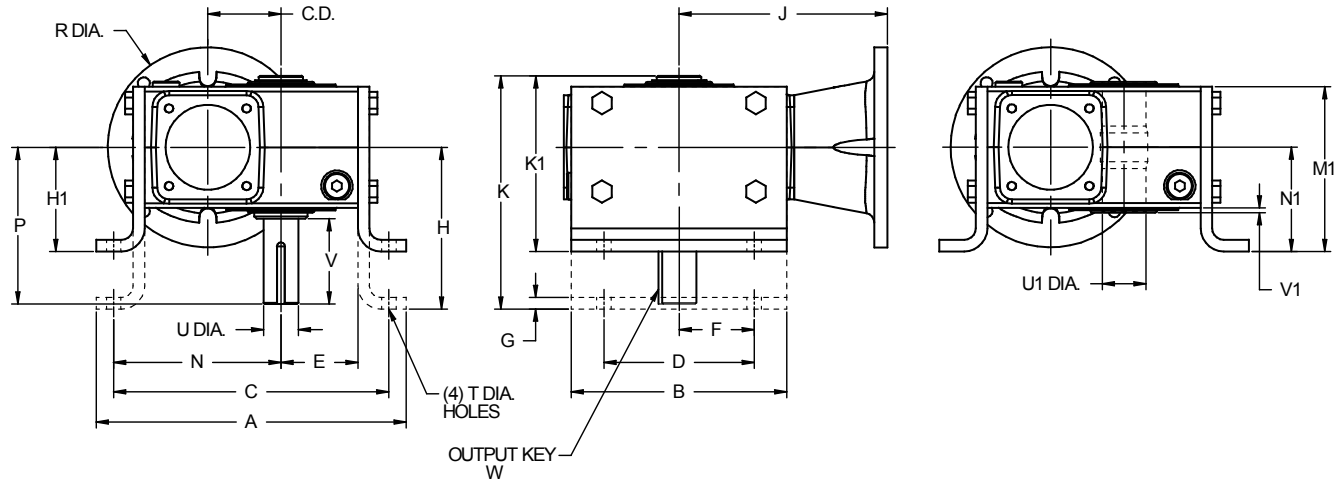

Case Size	C.D.	A	B	C	D	E	F	G	H	H1	K	K1	M1	N	N1	P
B02	1.33	7.09	4.33	6.16	3.25	1.72	1.63	0.25	3.56	2.31	5.66	4.41	3.85	3.69	1.93	4.00
B03	1.54	8.04	5.23	6.98	4.00	1.91	2.00	0.25	4.38	3.00	6.68	5.30	4.25	4.26	2.12	4.31
B04	1.75	8.44	5.98	7.38	4.00	2.06	2.00	0.31	4.38	3.00	6.72	5.34	4.29	4.51	2.15	4.31
B05	1.97	9.50	6.00	8.38	4.88	2.28	2.44	0.38	4.88	3.13	7.19	5.44	4.21	5.10	2.11	4.69
B06	2.38	10.06	7.00	8.95	4.88	2.50	2.44	0.38	5.25	3.38	7.57	5.70	4.25	5.44	2.13	5.09
B08	2.62	11.69	7.50	10.17	5.75	2.94	2.88	0.38	5.59	3.63	8.54	6.58	5.43	6.14	2.72	5.63
B09	3.00	13.25	9.00	11.14	6.00	3.25	3.00	0.38	5.88	3.94	8.83	6.89	5.43	6.76	2.72	6.75
B10	3.25	13.37	9.05	11.87	6.13	3.50	3.07	0.50	6.25	4.69	9.47	7.91	5.98	7.12	2.99	7.06
B11	3.54	16.84	9.50	14.88	7.88	3.39	3.94	0.50	7.50	5.00	11.09	8.59	6.65	8.99	3.33	7.75

Case Size	56C		143/145TC		182/184TC		213/215TC		OUTPUT SHAFT				W-KEY		WT (LBS)	
	T Dia.	J	R Dia.	J	R Dia.	J	R Dia.	J	R Dia.	U Dia.	U1 Dia.	V	V1	SQ.		LG
B02	11/32	4.74	6.5	4.74	6.5	NA	NA	NA	NA	0.750	1.000	1.88	0.12	3/16	1.00	10
B03	13/32	5.92	6.5	5.92	6.5	6.16	9.00	NA	NA	0.750	1.000	1.99	0.08	3/16	1.13	15
B04	13/32	6.18	6.5	6.18	6.5	6.42	9.00	NA	NA	1.000	1.438	1.97	0.08	1/4	1.25	18
B05	15/32	6.34	6.5	6.34	6.5	6.58	9.00	NA	NA	1.125	1.438	2.39	0.08	1/4	1.50	20
B06	15/32	6.77	6.5	6.77	6.5	7.01	9.00	NA	NA	1.125	1.438	2.77	0.08	1/4	1.88	25
B08	17/32	7.24	6.5	7.24	6.5	7.59	9.00	7.59	9.00	1.500	1.938	2.68	0.08	3/8	1.94	44
B09	17/32	7.64	6.5	7.64	6.5	7.98	9.00	7.98	9.00	1.500	2.188	3.80	0.08	3/8	2.00	51
B10	17/32	7.72	6.5	7.72	6.5	8.06	9.00	8.06	9.00	1.500	2.188	3.83	0.08	3/8	2.25	55
B11	9/16	8.15	6.5	8.15	6.5	8.50	9.00	8.50	9.00	1.875	2.938	4.15	0.10	1/2	2.63	76

NOTES: Refer to pages 13 - 14 for shaft and bore tolerances.

Refer to pages 29 - 30 for motor dimensions.

## Unit with End Mounted Base

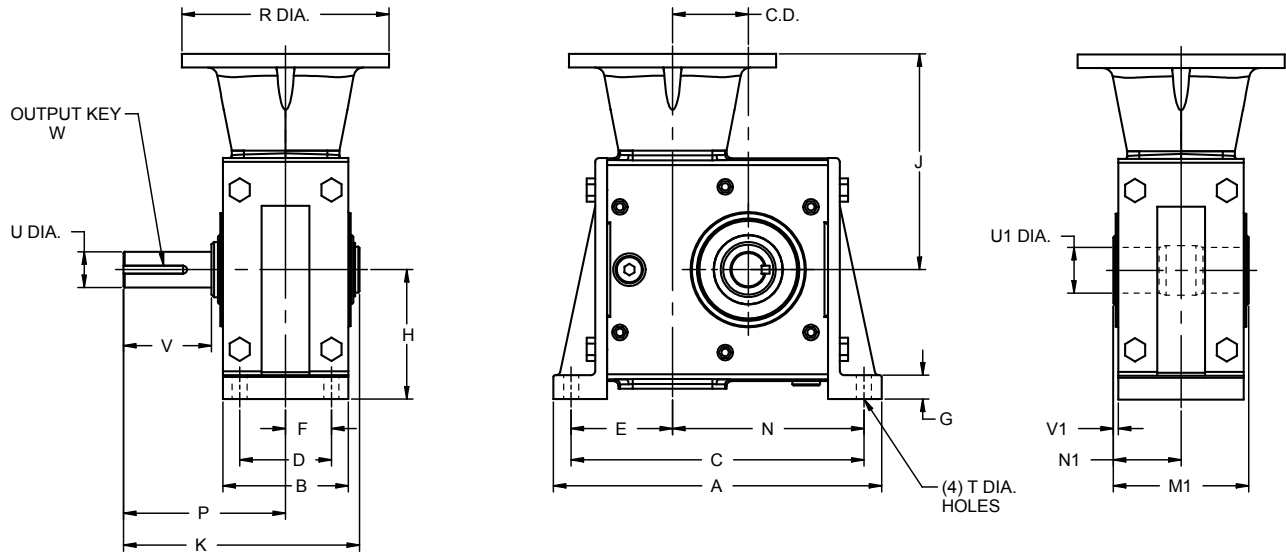

Case Size	C.D.	A	B	C	D	E	F	G	H	K	M1	N	N1	P	T Dia.
B02	1.33	7.28	2.76	6.41	2.00	2.48	1.00	0.53	2.94	6.10	3.85	3.93	1.93	4.00	11/32
B03	1.54	8.26	3.94	7.26	2.50	2.86	1.25	0.69	3.50	6.61	4.25	4.41	2.12	4.31	13/32
B04	1.75	8.62	3.94	7.63	2.50	2.88	1.25	0.69	3.50	6.65	4.29	4.75	2.15	4.31	13/32
B05	1.97	9.75	3.94	8.63	2.63	3.26	1.32	0.72	3.94	7.00	4.21	5.37	2.11	4.69	15/32
B06	2.38	10.31	3.94	9.19	2.88	3.18	1.44	0.75	4.06	7.41	4.25	6.00	2.13	5.09	15/32
B08	2.62	11.88	5.12	10.38	3.13	3.62	1.57	0.88	4.63	8.58	5.43	6.76	2.72	5.63	17/32
B09	3.00	13.45	5.12	11.38	3.88	3.88	1.94	0.88	5.62	9.70	5.43	7.50	2.72	6.75	17/32
B10	3.25	13.84	5.67	11.87	3.88	3.88	1.94	0.88	5.63	10.28	5.98	8.00	2.99	7.06	17/32
B11	3.54	16.85	6.12	14.88	5.00	5.43	2.50	0.94	6.50	11.34	6.65	9.45	3.33	7.75	19/32

Case Size	C.D.	56C		143/145TC		182/184TC		213/215TC		OUTPUT SHAFT				W-KEY		WT (LBS)
		J	R Dia.	J	R Dia.	J	R Dia.	J	R Dia.	U Dia.	U1 Dia.	V	V1	SQ.	LG	
B02	1.33	4.74	6.5	4.74	6.5	NA	NA	NA	NA	0.750	1.000	1.88	0.12	3/16	1.00	11
B03	1.54	5.92	6.5	5.92	6.5	6.16	9.00	NA	NA	0.750	1.000	1.99	0.08	3/16	1.13	16
B04	1.75	6.18	6.5	6.18	6.5	6.42	9.00	NA	NA	1.000	1.438	1.97	0.08	1/4	1.25	18
B05	1.97	6.34	6.5	6.34	6.5	6.58	9.00	NA	NA	1.125	1.438	2.39	0.08	1/4	1.50	21
B06	2.38	6.77	6.5	6.77	6.5	7.01	9.00	NA	NA	1.125	1.438	2.77	0.08	1/4	1.88	26
B08	2.62	7.24	6.5	7.24	6.5	7.59	9.00	7.59	9.00	1.500	1.938	2.68	0.08	3/8	1.94	44
B09	3.00	7.64	6.5	7.64	6.5	7.98	9.00	7.98	9.00	1.500	2.188	3.80	0.08	3/8	2.00	51
B10	3.25	7.72	6.5	7.72	6.5	8.06	9.00	8.06	9.00	1.500	2.188	3.83	0.08	3/8	2.25	55
B11	3.54	8.15	6.5	8.15	6.5	8.50	9.00	8.50	9.00	1.875	2.938	4.15	0.10	1/2	2.63	76

NOTES: Refer to pages 13 - 14 for shaft and bore tolerances.

Refer to pages 29 - 30 for motor dimensions.

## Unit with Output Bracket

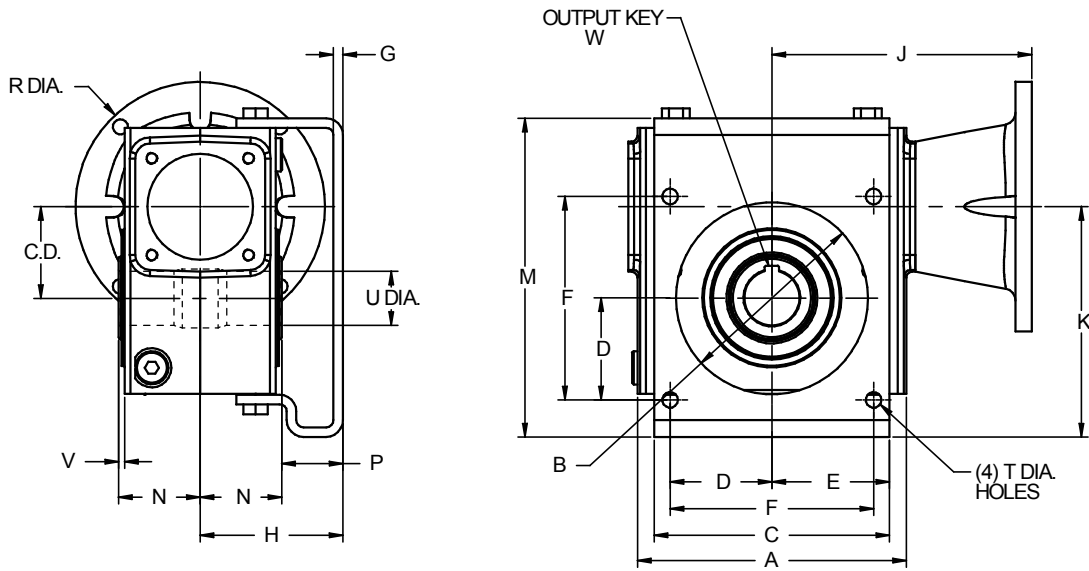

Case Size	C.D.	A	B	C	D	E	F	G	H	K	M	N	P	T Dia.
B02	1.33	4.33	3.62	4.25	1.77	2.13	3.54	0.19	3.00	3.75	5.55	1.93	1.07	11/32
B03	1.54	5.23	3.62	4.75	1.77	2.38	3.54	0.19	3.56	4.07	6.16	2.12	1.44	11/32
B04	1.75	5.98	4.06	4.81	2.08	2.41	4.16	0.19	3.50	4.53	6.66	2.15	1.35	11/32
B05	1.97	6.00	4.50	5.75	2.30	2.88	4.60	0.19	3.75	5.15	7.47	2.11	1.64	13/32
B06	2.38	7.00	5.00	6.13	2.65	3.07	5.30	0.25	3.72	6.00	8.30	2.13	1.59	13/32
B08	2.62	7.50	6.00	7.18	2.83	3.59	5.66	0.25	4.06	6.57	9.25	2.72	1.34	13/32
B09	3.00	9.00	7.00	8.50	3.18	4.25	6.36	0.25	4.50	7.14	10.02	2.72	1.78	13/32
B10	3.25	9.05	7.00	8.50	3.54	4.25	7.07	0.25	5.25	8.04	10.91	2.99	2.26	9/16
B11	3.54	9.50	8.56	9.50	3.54	4.75	7.07	0.25	5.25	9.19	12.35	3.33	1.92	9/16

Case Size	C.D.	56C		143/145TC		182/184TC		213/215TC		OUTPUT SHAFT			WT (LBS)
		J	R Dia.	J	R Dia.	J	R Dia.	J	R Dia.	U Dia.	V	W-KEY	
B02	1.33	4.74	6.5	4.74	6.5	NA	NA	NA	NA	1.000	0.12	1/4 x 3/16 x 3	9
B03	1.54	5.92	6.5	5.92	6.5	6.16	4.50	NA	NA	1.000	0.08	1/4 x 3/16 x 3	14
B04	1.75	6.18	6.5	6.18	6.5	6.42	4.50	NA	NA	1.438	0.08	3/8 x 1/4 x 3.15	16
B05	1.97	6.34	6.5	6.34	6.5	6.58	9.00	NA	NA	1.438	0.08	3/8 x 1/4 x 3.15	18
B06	2.38	6.77	6.5	6.77	6.5	7.01	9.00	NA	NA	1.438	0.08	3/8 x 1/4 x 3.15	23
B08	2.62	7.24	6.5	7.24	6.5	7.59	9.00	7.59	9.00	1.938	0.08	1/2 x 3/8 x 4.10	40
B09	3.00	7.64	6.5	7.64	6.5	7.98	9.00	7.98	9.00	2.188	0.08	1/2 x 3/8 x 4.10	47
B10	3.25	7.72	6.5	7.72	6.5	8.06	9.00	8.06	9.00	2.188	0.08	1/2 x 3/8 x 4.50	50
B11	3.54	8.15	6.5	8.15	6.5	8.50	9.00	8.50	9.00	2.938	1.00	3/4 x 1/2 x 5.50	70

NOTES: Refer to pages 13 - 14 for shaft and bore tolerances.

Refer to pages 29 - 30 for motor dimensions.

## Standard Unit (No Base)

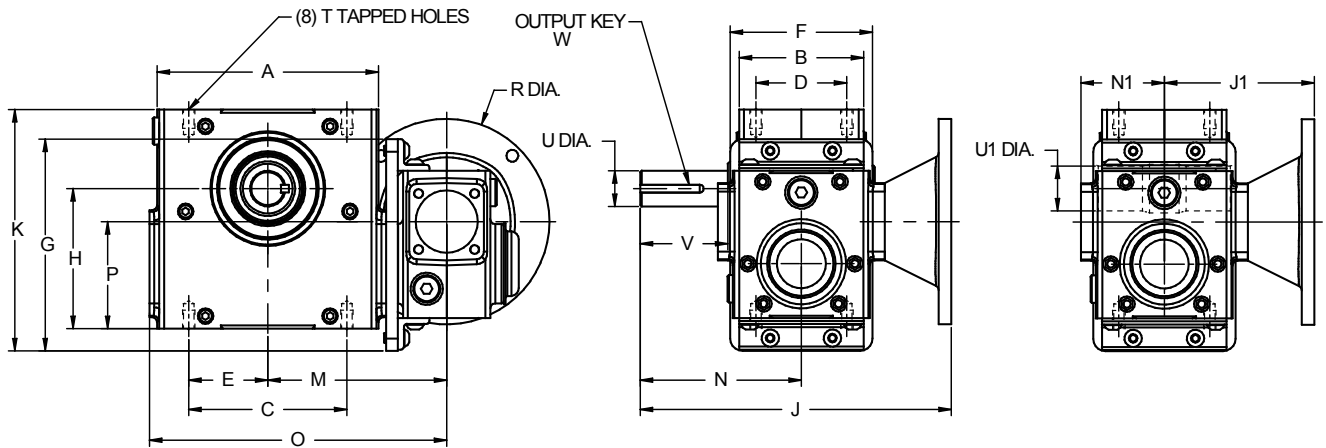

Size	A	B	C	D	E	F	G	H	K	M	N	N1	O	P	T Dia.
B0520	6.00	3.94	5.00	2.88	2.50	4.50	6.69	4.10	7.00	5.28	4.69	2.64	8.58	3.46	M10 x 0.59
B0620	7.00	3.94	5.00	2.88	2.50	4.50	6.69	4.43	7.63	5.71	5.09	2.64	9.45	3.39	M10 x 0.59
B0820	7.50	5.12	6.38	3.38	3.19	5.98	8.27	5.05	8.87	6.79	5.63	3.15	11.00	4.18	M10 x 0.59
B0920	9.00	5.12	7.00	4.00	3.50	5.98	8.27	5.63	9.56	7.19	6.75	3.15	11.79	4.38	M12 x 0.71
B1020	9.05	5.67	7.50	4.00	3.75	5.98	8.82	5.88	10.25	7.22	7.06	3.31	11.91	4.59	M12 x 0.71
B1120	9.50	5.12	7.50	4.00	3.75	5.98	8.82	6.46	10.43	7.66	7.75	3.31	12.78	4.88	M16 x 0.87

Case Size	56C			143/145TC			182/184TC			OUTPUT SHAFT			W-KEY		WT (LBS)
	J	J1	R Dia.	J	J1	R Dia.	J	J1	R Dia.	U Dia.	U1 Dia.	V	SQ.	LG	
B0520	9.43	4.74	6.5	9.43	4.74	6.5	NA	NA	NA	1.125	1.438	2.39	1/4	1.50	32
B0620	9.83	4.74	6.5	9.83	4.74	6.5	NA	NA	NA	1.125	1.438	2.77	1/4	1.88	37
B0820	11.81	6.18	6.5	11.81	6.18	6.5	NA	NA	NA	1.500	1.938	2.68	3/8	1.94	65
B0920	12.93	6.18	6.5	12.93	6.18	6.5	NA	NA	NA	1.500	2.188	3.80	3/8	2.00	72
B1020	13.40	6.34	6.5	13.40	6.34	6.5	13.68	6.62	9.00	1.500	2.188	3.83	3/8	2.25	78
B1120	14.09	6.34	6.5	14.09	6.34	6.5	14.37	6.62	9.00	1.875	2.938	4.15	1/2	2.63	98

NOTES: Refer to pages 13 - 14 for shaft and bore tolerances.

Refer to pages 29 - 30 for motor dimensions.

## Standard Unit (No Base)

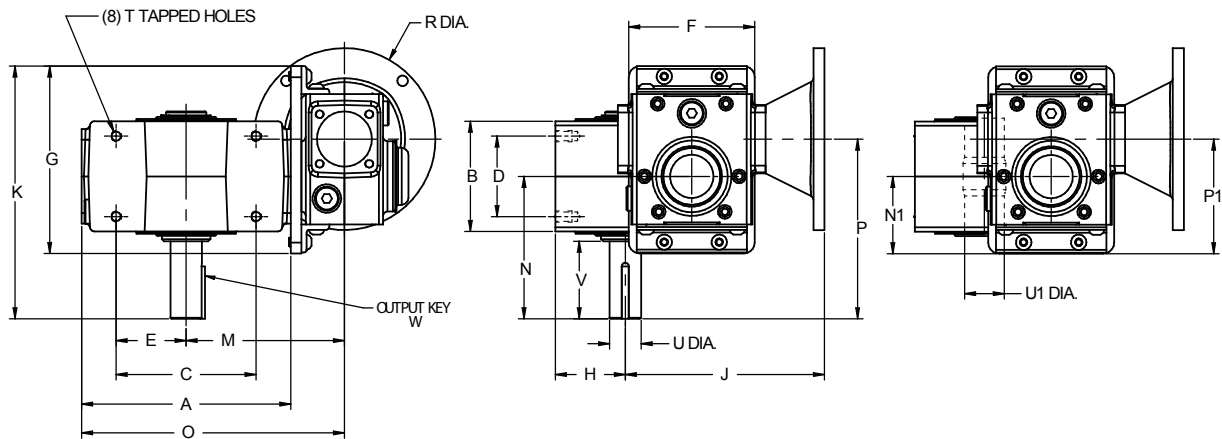

Size	A	B	C	D	E	F	G	H	K	M	N	N1	O	P	P1
B0520	6.61	3.94	5.00	2.88	2.50	4.50	6.69	2.28	8.63	5.28	4.69	2.76	8.58	6.02	4.09
B0620	7.48	3.94	5.00	2.88	2.50	4.50	6.69	2.50	9.03	5.71	5.09	2.76	9.45	6.42	4.09
B0820	8.43	5.12	6.38	3.38	3.19	5.98	8.27	2.94	10.59	6.79	5.63	3.31	11.00	7.38	5.06
B0920	9.21	5.12	7.00	4.00	3.50	5.98	8.27	3.25	11.71	7.19	6.75	3.31	11.79	8.50	5.06
B1020	9.37	5.67	7.50	4.00	3.75	5.98	8.82	3.50	12.37	7.22	7.06	3.50	11.91	9.03	5.47
B1120	10.24	5.12	7.50	4.00	3.75	5.98	8.82	3.39	13.06	7.66	7.75	3.50	12.78	9.72	5.47

Case Size	T Dia.	56C		143/145TC		182/184TC		OUTPUT SHAFT			W-KEY		WT (LBS)
		J	R Dia.	J	R Dia.	J	R Dia.	U Dia.	U1 Dia.	V	SQ.	LG	
B0520	M10x 0.59	6.71	6.5	6.71	6.5	NA	NA	1.125	1.438	2.39	1/4	1.50	32
B0620	M10x 0.59	7.12	6.5	7.12	6.5	NA	NA	1.125	1.438	2.77	1/4	1.88	37
B0820	M10x 0.59	8.80	6.5	8.80	6.5	NA	NA	1.500	1.938	2.68	3/8	1.94	65
B0920	M12 x 0.71	9.18	6.5	9.18	6.5	NA	NA	1.500	2.188	3.80	3/8	2.00	72
B1020	M12 x 0.71	9.59	6.5	9.59	6.5	9.87	9.00	1.500	2.188	3.83	3/8	2.25	78
B1120	M16 x 0.87	9.88	6.5	9.88	6.5	10.16	9.00	1.875	2.938	4.15	1/2	2.63	98

NOTES: Refer to pages 13 - 14 for shaft and bore tolerances.

Refer to pages 29 - 30 for motor dimensions.

## Unit with Output Bracket

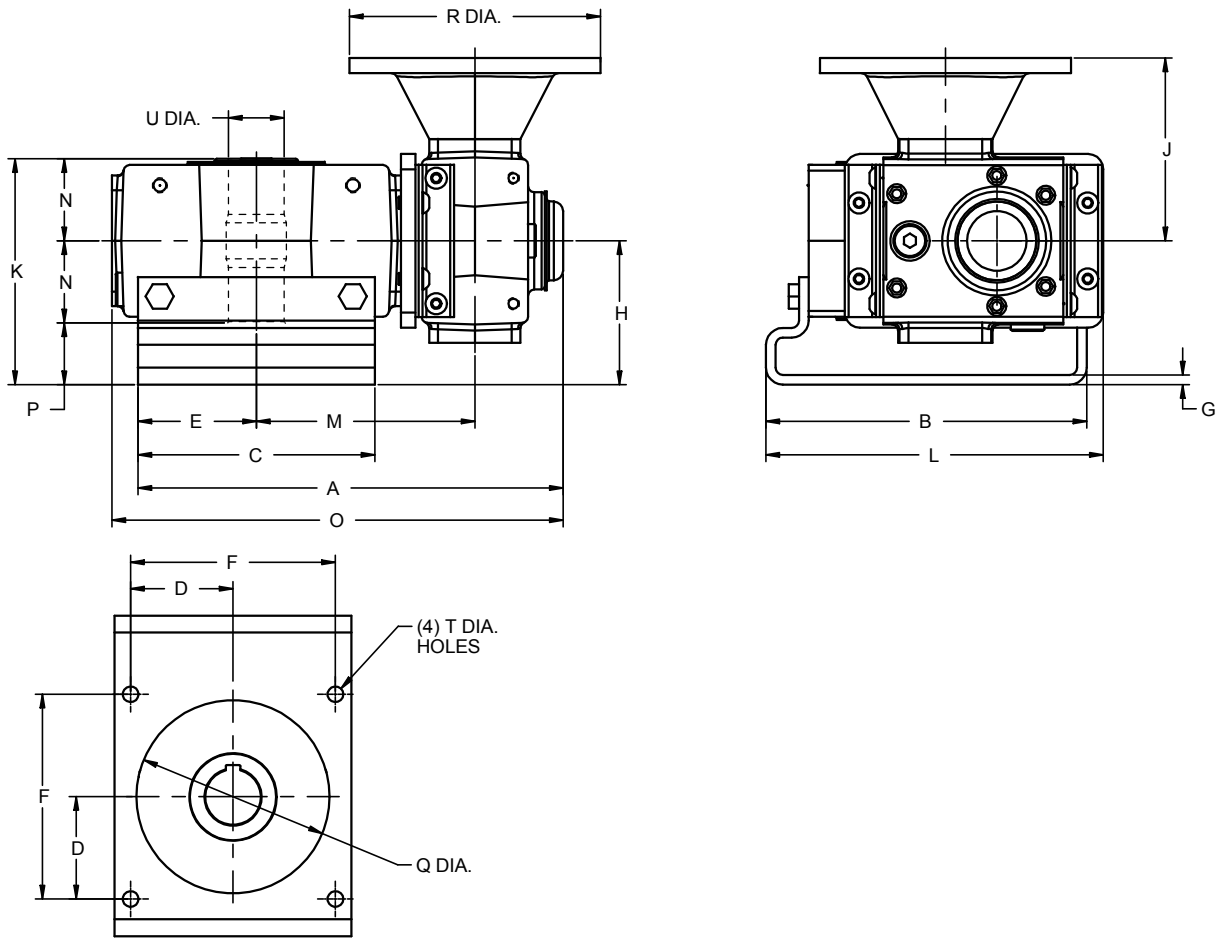

Size	A	B	C	D	E	F	G	H	K	L	M	N
B0520	10.46	7.47	5.75	2.30	2.87	4.60	0.19	3.75	5.86	7.90	5.28	2.11
B0620	11.09	8.30	6.13	2.65	3.07	5.30	0.25	3.72	5.85	8.75	5.71	2.13
B0820	12.95	9.25	7.18	2.83	3.59	5.66	0.25	4.06	6.78	9.87	6.79	2.72
B0920	14.00	10.02	8.50	3.18	4.25	6.36	0.25	4.50	7.22	10.44	7.19	2.72
B1020	14.01	10.91	8.50	3.54	4.25	7.07	0.25	5.25	8.24	11.53	7.22	2.99
B1120	14.94	12.35	9.50	3.54	4.75	7.07	0.25	5.25	8.58	12.67	7.66	3.33

Case Size	56C		143/145TC		182/184TC		T Dia	U Dia	WT (LBS)			
	O	P	J	R Dia.	J	R Dia.						
B0520	10.89	1.64	4.50	4.74	6.5	4.74	6.5	NA	NA	13/32	1.438	32
B0620	11.76	1.59	5.00	4.74	6.5	4.74	6.5	NA	NA	13/32	1.438	37
B0820	13.57	1.34	6.00	6.18	6.5	6.18	6.5	NA	NA	13/32	1.938	65
B0920	14.35	1.78	7.00	6.18	6.5	6.18	6.5	NA	NA	13/32	2.188	72
B1020	14.44	2.26	7.00	6.34	6.5	6.34	6.5	6.62	9.00	9/16	2.188	78
B1120	15.31	1.92	8.56	6.34	6.5	6.34	6.5	6.62	9.00	9/16	2.938	98

NOTES: Refer to pages 13 - 14 for shaft and bore tolerances.

Refer to pages 29 - 30 for motor dimensions.

## Unit with Output Bracket

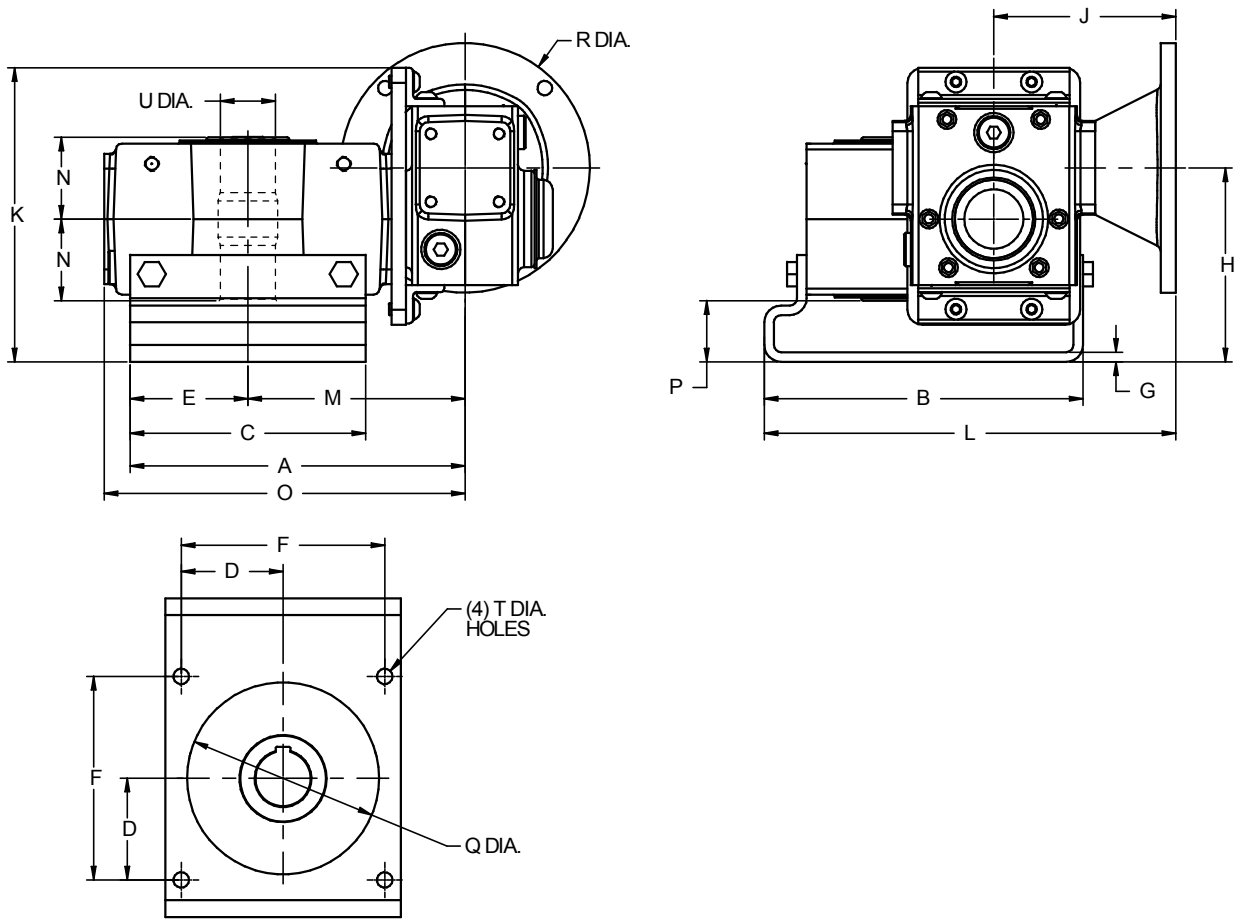

Size	A	B	C	D	E	F	G	H	K	M	N	O	P
B0520	8.16	7.47	5.75	2.30	2.88	4.60	0.19	5.08	7.69	5.28	2.11	8.58	1.64
B0620	8.59	8.30	5.75	2.65	2.88	5.30	0.25	5.08	7.66	5.71	2.13	9.45	1.59
B0820	10.38	9.25	7.18	2.83	3.59	5.66	0.25	5.81	9.02	6.79	2.72	11.00	1.34
B0920	11.44	10.02	8.50	3.18	4.25	6.36	0.25	6.25	9.46	7.19	2.72	11.79	1.78
B1020	11.48	10.91	8.50	3.54	4.25	7.07	0.25	7.22	10.56	7.22	2.99	11.91	2.26
B1120	12.41	12.35	9.50	3.54	4.75	7.07	0.25	7.22	10.56	7.66	3.33	12.78	1.92

Case Size	Q Dia	56C			143/145TC			182/184TC			T Dia	U Dia	WT (LBS)
		J	L	R Dia.	J	L	R Dia.	J	L	R Dia.			
B0520	4.50	4.74	9.88	6.5	4.74	9.88	6.5	NA	NA	NA	13/32	1.438	32
B0620	5.00	4.74	10.73	6.5	4.74	10.73	6.5	NA	NA	NA	13/32	1.438	37
B0820	6.00	6.18	12.74	6.5	6.18	12.74	6.5	NA	NA	NA	13/32	1.938	65
B0920	7.00	6.18	13.31	6.5	6.18	13.31	6.5	NA	NA	NA	13/32	2.188	72
B1020	7.00	6.34	14.37	6.5	6.34	14.37	6.5	6.62	14.65	9.00	9/16	2.188	78
B1120	8.56	6.34	15.51	6.5	6.34	15.51	6.5	6.62	15.79	9.00	9/16	2.938	98

NOTES: Refer to pages 13 - 14 for shaft and bore tolerances.

Refer to pages 29 - 30 for motor dimensions.

## Standard Unit (No Base)

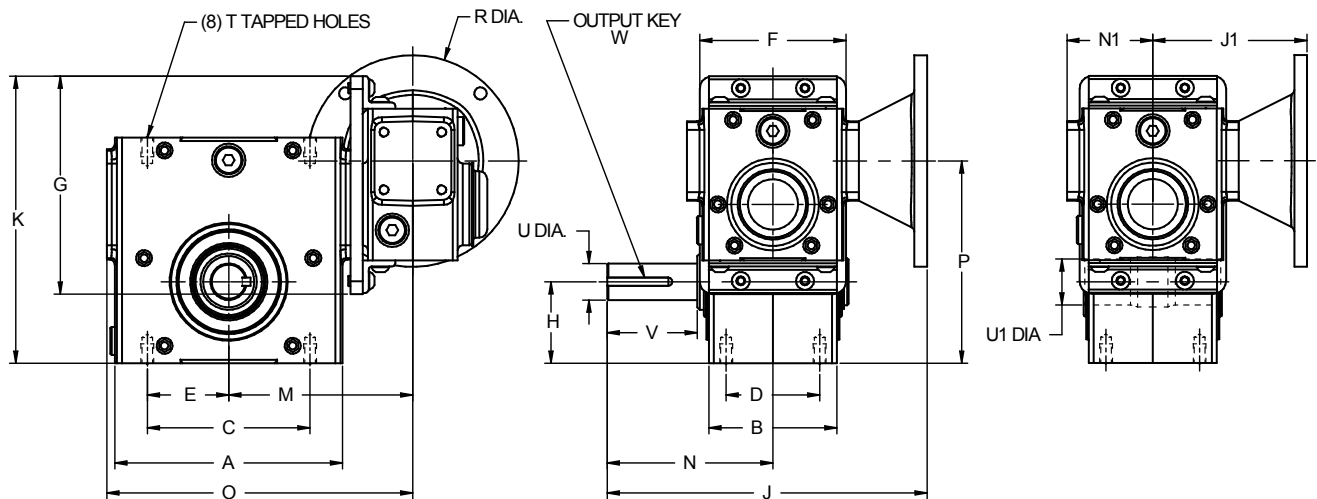

Size	A	B	C	D	E	F	G	H	K	M	N	N1	O	P	T Dia
B0520	6.00	3.94	5.00	2.88	2.50	4.50	6.69	2.28	8.19	5.28	4.69	2.64	8.58	5.58	M10 x 0.59
B0620	7.00	3.94	5.00	2.88	2.50	4.50	6.69	2.50	8.82	5.71	5.09	2.64	9.45	6.21	M10 x 0.59
B0820	7.50	5.12	6.38	3.38	3.19	5.98	8.27	2.94	10.52	6.79	5.63	3.15	11.00	7.31	M10 x 0.59
B0920	9.00	5.12	7.00	4.00	3.50	5.98	8.27	3.25	11.21	7.19	6.75	3.15	11.79	8.00	M12 x 0.71
B1020	9.05	5.67	7.50	4.00	3.75	5.98	8.82	3.50	12.06	7.22	7.06	3.31	11.91	8.72	M12 x 0.71
B1120	9.50	5.12	7.50	4.00	3.75	5.98	8.82	3.39	12.24	7.66	7.75	3.31	12.78	8.90	M16 x 0.87

Case Size	56C			143/145TC			182/184TC			OUTPUT SHAFT			W-KEY		WT (LBS)
	J	J1	R Dia.	J	J1	R Dia.	J	J1	R Dia.	U Dia.	U1 Dia.	V	SQ.	LG	
B0520	9.43	4.74	6.5	9.43	4.74	6.5	NA	NA	NA	1.125	1.438	2.39	1/4	1.50	32
B0620	9.83	4.74	6.5	9.83	4.74	6.5	NA	NA	NA	1.125	1.438	2.77	1/4	1.88	37
B0820	11.81	6.18	6.5	11.81	6.18	6.5	NA	NA	NA	1.500	1.938	2.68	3/8	1.94	65
B0920	12.93	6.18	6.5	12.93	6.18	6.5	NA	NA	NA	1.500	2.188	3.80	3/8	2.00	72
B1020	13.40	6.34	6.5	13.40	6.34	6.5	13.68	6.62	9.00	1.500	2.188	3.83	3/8	2.25	78
B1120	14.09	6.34	6.5	14.09	6.34	6.5	14.37	6.62	9.00	1.875	2.938	4.15	1/2	2.63	98

NOTES: Refer to pages 13 - 14 for shaft and bore tolerances.

Refer to pages 29 - 30 for motor dimensions.

## Standard Unit (No Base)

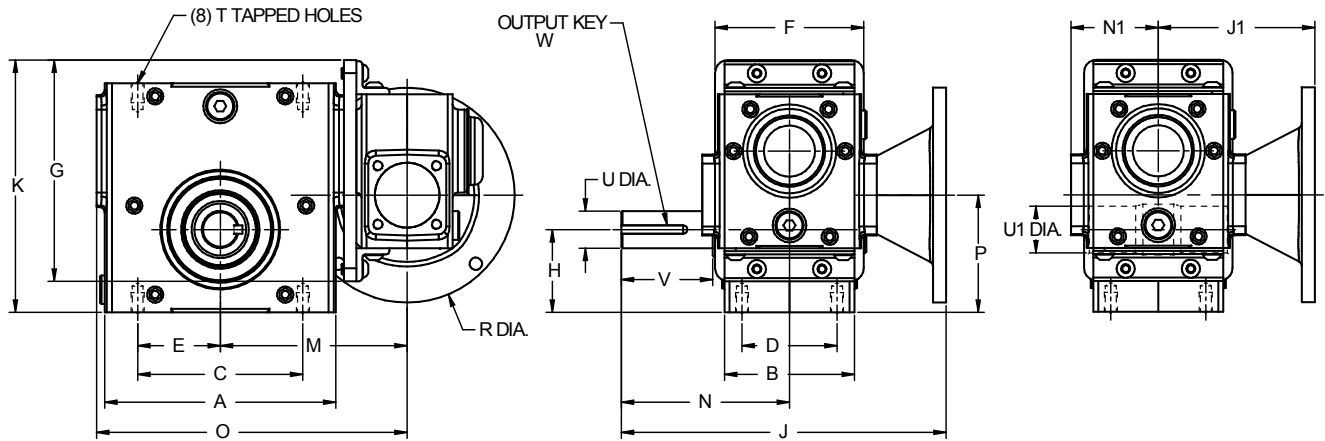

Size	A	B	C	D	E	F	G	H	K	M	N	N1	O	P	T Dia
B0520	6.00	3.94	5.00	2.88	2.50	4.50	6.69	2.28	7.00	5.28	4.69	2.64	8.58	2.92	M10 x 0.59
B0620	7.00	3.94	5.00	2.88	2.50	4.50	6.69	2.50	7.63	5.71	5.09	2.64	9.45	3.54	M10 x 0.59
B0820	7.50	5.12	6.38	3.38	3.19	5.98	8.27	2.94	8.87	6.79	5.63	3.15	11.00	3.82	M10 x 0.59
B0920	9.00	5.12	7.00	4.00	3.50	5.98	8.27	3.25	9.56	7.19	6.75	3.15	11.79	4.50	M12 x 0.71
B1020	9.05	5.67	7.50	4.00	3.75	5.98	8.82	3.50	10.25	7.22	7.06	3.31	11.91	4.78	M12 x 0.71
B1120	9.50	5.12	7.50	4.00	3.75	5.98	8.82	3.39	10.43	7.66	7.75	3.31	12.78	4.96	M16 x 0.87

Case Size	56C			143/145TC			182/184TC			OUTPUT SHAFT			W-KEY		WT (LBS)
	J	J1	R Dia.	J	J1	R Dia.	J	J1	R Dia.	U Dia.	U1 Dia.	V	SQ.	LG	
B0520	9.43	4.74	6.5	9.43	4.74	6.5	NA	NA	NA	1.125	1.438	2.39	1/4	1.50	32
B0620	9.83	4.74	6.5	9.83	4.74	6.5	NA	NA	NA	1.125	1.438	2.77	1/4	1.88	37
B0820	11.81	6.18	6.5	11.81	6.18	6.5	NA	NA	NA	1.500	1.938	2.68	3/8	1.94	65
B0920	12.93	6.18	6.5	12.93	6.18	6.5	NA	NA	NA	1.500	2.188	3.80	3/8	2.00	72
B1020	13.40	6.34	6.5	13.40	6.34	6.5	13.68	6.62	9.00	1.500	2.188	3.83	3/8	2.25	78
B1120	14.09	6.34	6.5	14.09	6.34	6.5	14.37	6.62	9.00	1.875	2.938	4.15	1/2	2.63	98

NOTES: Refer to pages 13 - 14 for shaft and bore tolerances.

Refer to pages 29 - 30 for motor dimensions.



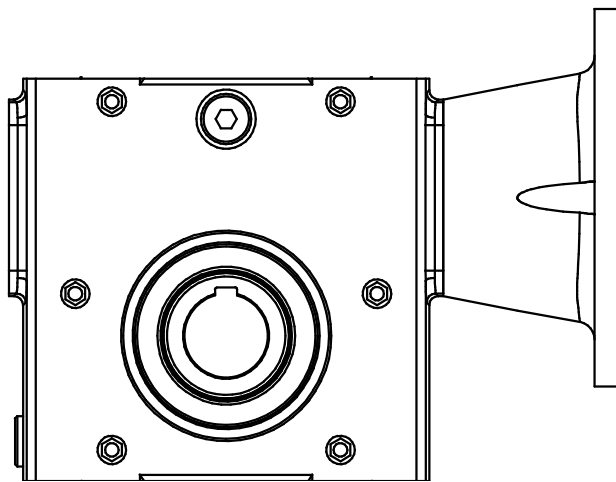
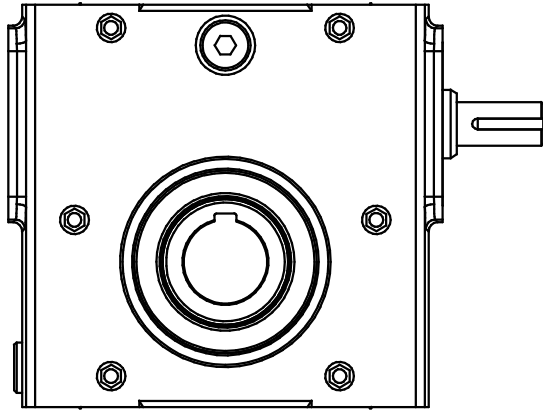

DIMENSIONAL COMPARISON  
**SERIES B**

## Standard Units

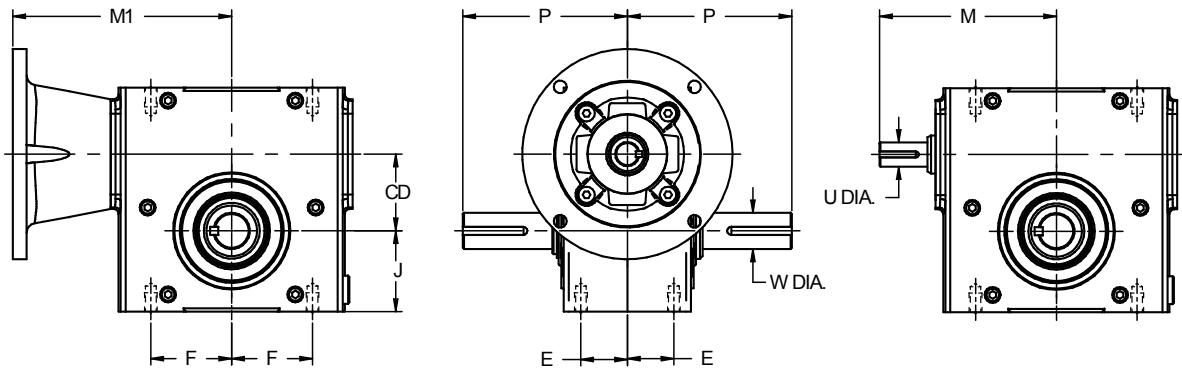

Manufacturer	Unit	CD	E	F	J	P	W Dia.	M	U Dia.	M1*
Series B	B021W/B021WM	1.33	1.00	1.63	1.72	4.00	0.625 **	4.22	0.625	4.74
Perfection-Predator	U13/UC13	1.33	1.00	1.63	1.72	4.00	0.625	3.80	0.500	3.38
Boston	F713/713	1.33	1.00	1.63	1.72	4.00	0.625	3.91	0.500	3.94
Grove - Old	BMQ1133/B1133	1.33	1.00	1.63	1.72	3.99	0.625	4.45	0.500	3.46
Grove - New	BMQ213/B213	1.33	1.00	1.63	1.72	4.00	0.625	3.82	0.500	3.46
Grove - OE	13U/13UF	1.33	1.00	1.63	1.72	4.00	0.750	3.82	0.500	3.46
Falk Omni Box	133WBM/133WB	1.33	1.00	1.63	1.72	3.99	0.625	4.45	0.500	3.46
Sterling	133BQ/133BR	1.33	1.00	1.63	1.72	3.99	0.625	4.45	0.500	3.46
Ohio	133MQ/133B	1.33	1.00	1.63	1.72	4.00	0.625	3.69	0.500	3.96
EPT - Raider	133Q/133U	1.33	1.00	1.63	1.72	4.00	0.625	4.03	0.500	3.94
Baldor	F913/S913	1.33	1.00	1.63	1.72	4.00	0.625	3.91	0.500	3.94
Leeson	B613/BMQ613	1.33	1.00	1.63	1.72	4.00	0.625	3.88	0.500	3.42
Alling Lander	13U/13UF	1.33	1.00	1.63	1.72	4.00	0.750	3.82	0.500	3.46

\* - for 56C frame

\*\* - Dimension shown is for the Reduced Diameter Shaft Option

Manufacturer	Unit	CD	E	F	J	P	W Dia.	M	U Dia.	M1*
Series B	B031W/B031WM	1.54	1.38	2.09	1.91	4.31	0.750	4.87	0.750	5.92
Boston	F715/715	1.54	1.38	2.09	1.91	4.31	0.750	4.69	0.625	4.50
Grove - Old	BMQ1154/B1154	1.54	1.38	2.09	1.91	4.31	0.750	4.91	0.625	3.99
Grove - New	BMQ215/B215	1.54	1.38	2.09	1.91	4.31	0.750	4.35	0.625	3.99
EPT - Raider	154Q/154U	1.54	1.38	2.09	1.91	4.31	0.750	4.69	0.625	4.52

\* - for a NEMA 56C frame

Manufacturer	Unit	CD	E	F	J	P	W Dia.	M	U Dia.	M1*
Series B	B041W/B041WM	1.75	1.38	2.09	2.06	4.31	0.875 **	5.13	0.750	6.18
Perfection-Predator	U18/UC18	1.75	1.38	2.09	2.06	4.31	0.875	4.75	0.625	4.04
Boston	F718/718	1.75	1.38	2.09	2.06	4.31	0.875	4.88	0.625	4.69
Grove - Old	BMQ1175/B1175	1.75	1.38	2.09	2.06	4.31	0.875	5.08	0.625	4.09
Grove - New	BMQ218/B218	1.75	1.38	2.09	2.06	4.31	0.875	4.45	0.625	4.09
Falk Omni Box	175WBM/175WB	1.75	1.38	2.09	2.06	4.31	0.875	5.08	0.625	4.09
Sterling	175AQ/175AR	1.75	1.38	2.09	2.06	4.31	0.875	5.08	0.625	4.09
Ohio	175MQ/175B	1.75	1.38	2.09	2.06	4.31	0.875	4.75	0.625	4.44
EPT - Raider	175Q/175U	1.75	1.38	2.09	2.06	4.31	0.875	4.68	0.625	4.38
Baldor	F918/S918	1.75	1.38	2.09	2.06	4.31	0.875	4.88	0.625	4.69
Leeson	B618/BMQ618	1.75	1.38	2.09	2.06	4.31	0.875	4.44	0.625	3.99
Dodge/Tigear	Q175/S175	1.75	1.38	2.09	1.99	4.31	0.875	4.75	0.625	4.94

\* - for 56C / 143 TC frame

\*\* - Dimension shown is for the Reduced Diameter Shaft Option

Manufacturer	Unit	CD	E	F	J	P	W Dia.	M	U Dia.	M1*
Series B	B051W/B051WM	1.97	1.44	2.50	2.28	4.69	1.000 **	5.20	0.750	6.34
Perfection-Predator	U218/UC21	2.06	1.44	2.50	2.28	4.69	1.000	5.13	0.625	4.35
Boston	F721/721	2.06	1.44	2.50	2.28	4.69	1.000	5.13	0.625	5.06
Ohio	206MQ/206B	2.06	1.44	2.50	2.28	4.69	1.000	5.16	0.625	4.75
EPT - Raider	206Q/206U	2.06	1.44	2.50	2.28	4.69	1.000	5.06	0.625	4.75
Baldor	F921/S921	2.06	1.44	2.50	2.28	4.69	1.000	4.85	0.625	4.40
Leeson	B621/BMQ621	2.06	1.44	2.50	2.28	4.68	1.000	4.85	0.625	4.40
Dodge/Tigear	Q200/S200	2.06	1.44	2.50	2.24	4.69	1.000	5.12	0.625	5.00

\* - for 56C/143TC frames

\*\* - Dimension shown is for the Reduced Diameter Shaft Option

## Standard Units (Continued)

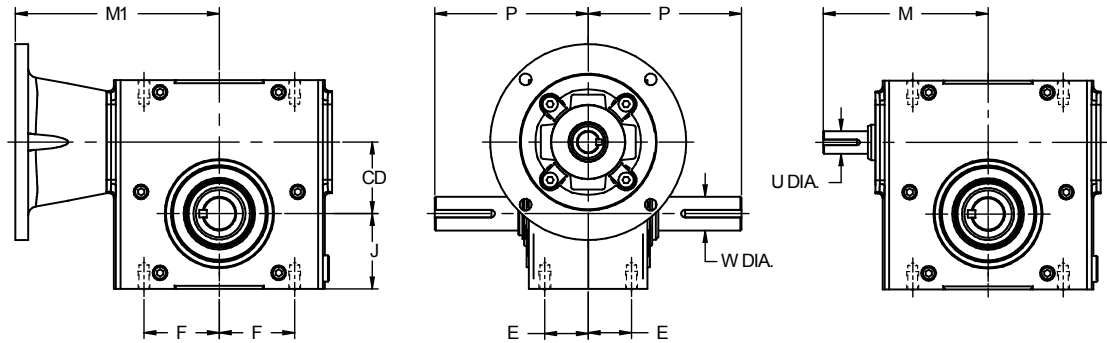

Manufacturer	Unit	CD	E	F	J	P	W Dia.	M	U Dia.	M1*
Series B	B061W/B061WM	2.38	1.44	2.50	2.50	5.09	1.125	5.47	0.750	6.77
Perfection-Predator	U214/UC24	2.38	1.44	2.50	2.50	5.09	1.125	5.75	0.750	4.75
Boston	F724/724	2.38	1.44	2.50	2.50	5.09	1.125	5.75	0.750	5.25
Grove - Old	BMQ1238/B1238	2.38	1.43	2.50	2.50	5.14	1.125	6.05	0.750	4.63
Grove - New	BMQ224/B224	2.38	1.44	2.50	2.50	5.14	1.125	5.51	0.750	4.63
Falk Omni Box	238WBM/238WB	2.38	1.43	2.50	2.50	5.14	1.125	6.05	0.750	4.63
Sterling	238AQ/238AR	2.38	1.43	2.50	2.50	5.14	1.125	6.05	0.750	4.63
Ohio	238MQ/238B	2.38	1.44	2.50	2.50	5.09	1.125	5.81	0.750	5.25
EPT - Raider	238Q/238U	2.38	1.44	2.50	2.50	5.08	1.125	5.44	0.750	5.06
Baldor	F924/S924	2.38	1.44	2.50	2.50	5.09	1.125	5.51	0.750	4.63
Leeson	B624/BMQ624	2.38	1.44	2.50	2.50	5.09	1.125	5.51	0.750	4.63

\* - for 56C / 143 TC frame

Manufacturer	Unit	CD	E	F	J	P	W Dia.	M	U Dia.	M1*
Series B	B081W/B081WM	2.625	1.69	3.19	2.94	5.63	1.125 **	7.23	1.188	7.24
Perfection-Predator	U26/UC26	2.625	1.69	3.19	2.94	5.63	1.125	6.31	0.750	5.48
Boston	F726/726	2.625	1.69	3.19	2.94	5.63	1.125	6.31	0.750	5.75
Grove - Old	BMQ1262/B1262	2.625	1.69	3.19	2.94	5.63	1.250	6.57	0.750	5.19
Grove - New	BMQ226/B226	2.625	1.69	3.19	2.94	5.63	1.250	6.07	0.750	5.19
Falk Omni Box	262WBM/262WB	2.625	1.69	3.19	2.94	5.63	1.250	6.57	0.750	5.19
Sterling	262AQ/262AR	2.625	1.69	3.19	2.94	5.63	1.250	6.57	0.750	5.19
Ohio	262MQ/262B	2.625	1.69	3.19	2.94	5.63	1.125	6.31	0.750	5.62
EPT - Raider	262Q/262U	2.625	1.69	3.19	2.94	5.63	1.125	6.23	0.750	5.69
Baldor	F926/S926	2.625	1.69	3.19	2.94	5.62	1.125	6.31	0.750	5.75
Leeson	B626/BMQ626	2.625	1.69	3.19	2.94	5.63	1.125	6.12	0.750	5.23
Dodge/Tigear	262	2.625	1.69	3.19	2.88	5.63	1.125	6.32	0.750	6.63

\* - for 56C/143 TC frame

\*\* - Dimension shown is for the Reduced Diameter Shaft Option

Manufacturer	Unit	CD	E	F	J	P	W Dia.	M	U Dia.	M1*
Series B	B091W/B091WM	3.00	2.00	3.50	3.25	6.75	1.250 **	7.63	1.188	7.64
Grove - Old	BMQ1300/B1300	3.00	2.00	3.50	3.25	6.75	1.250	7.25	0.875	5.69
Grove - New	BMQ230/B230	3.00	2.00	3.50	3.25	6.75	1.250	6.57	0.875	5.69
Falk Omni Box	300WBM/300WB	3.00	2.00	3.50	3.25	6.75	1.250	7.25	0.875	5.69
Sterling	300AQ/300AR	3.00	2.00	3.50	3.25	6.75	1.250	7.25	0.875	5.69
Ohio	300MQ/300B	3.00	2.00	3.50	3.25	6.75	1.250	7.50	0.875	6.25
EPT - Raider	300Q/300U	3.00	2.00	3.50	3.25	6.75	1.250	7.50	0.875	6.25

\* - for 56C/143 TC frame

\*\* - Dimension shown is for the Reduced Diameter Shaft Option

Manufacturer	Unit	CD	E	F	J	P	W Dia.	M	U Dia.	M1*
Series B	B101W/B101WM	3.25	2.00	3.75	3.50	7.06	1.375 **	7.64	1.188	7.72
Perfection-Predator	U32/UG32	3.25	2.00	3.75	3.50	7.06	1.375	7.44	0.875	6.22
Boston	F732/732B	3.25	2.00	3.75	3.50	7.06	1.375	7.44	0.875	7.00
Grove - Old	BMQ232/B232	3.25	2.00	3.75	3.50	7.06	1.500	6.76	0.875	6.31
Grove - New	BMQ230/B230	3.25	2.00	3.75	3.50	7.06	1.500	6.76	0.875	5.88
Falk Omni Box	300WBM/300WB	3.25	2.00	3.75	3.50	7.06	1.500	6.76	0.875	6.31
Sterling	300AQ/300AR	3.25	2.00	3.75	3.50	7.06	1.500	6.76	0.875	6.31
EPT - Raider	325Q/325U	3.25	2.00	3.75	3.50	7.06	1.375	7.06	0.875	7.00
Ohio	325MQ/325B	3.25	2.00	3.75	3.50	7.06	1.375	7.19	0.875	6.47
Baldor	F932/S932	3.25	2.00	3.75	3.50	7.06	1.375	7.44	0.875	7.00
Leeson	B632/BMQ632	3.25	2.00	3.75	3.50	7.06	1.375	7.44	0.875	6.56

\* - for 180 frame

\*\* - Dimension shown is for the Reduced Diameter Shaft Option

## Standard Units (Continued)

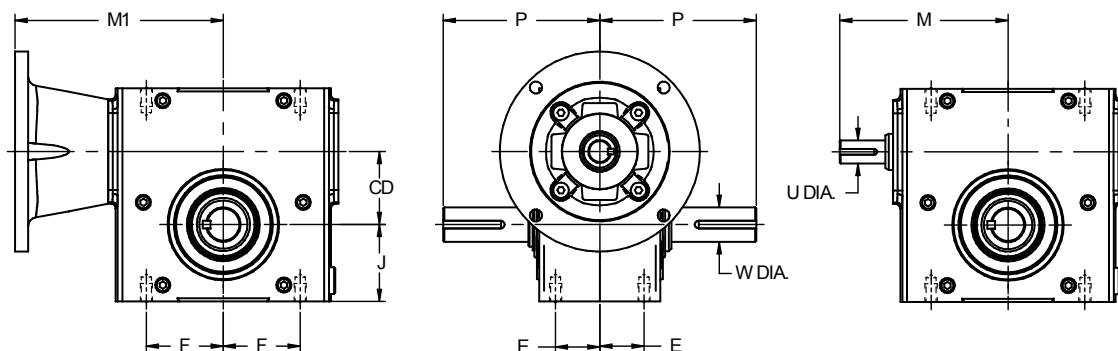

Manufacturer	Unit	CD	E	F	J	P	W Dia.	M	U Dia.	M1*
Series B	B111W/B111WM	3.54	2.00	3.75	3.39	7.75	1.625 **	8.39	1.188	8.50
Dodge/Tigear	350	3.50	2.00	3.75	4.00	7.06	1.500	7.19	0.875	7.41

\* - for 180 frame

\*\* - Dimension shown is for the Reduced Diameter Shaft Option

Manufacturer	Unit	CD	E	F	J	P	W Dia.	M	U Dia.	M1*
Series B	B111W/B111WM	3.54	2.00	3.75	3.39	7.75	1.625 **	8.39	1.188	8.50
Perfection-Modular	H38/HG38	3.75	1.50	3.44	3.94	6.69	1.500	7.50	1.000	6.10
Hub City	381/384	3.75	1.50	3.44	3.94	6.69	1.500	7.50	1.000	6.63
Perfection-Predator	U38/UG38	3.75	2.38	4.25	3.88	7.75	1.625	8.38	1.000	6.73
Boston	F738/S738B	3.75	2.38	4.25	3.88	7.75	1.625	8.38	1.000	7.50
EPT-Raider	375U/375Q	3.75	2.38	4.25	3.88	7.75	1.625	7.84	1.000	7.29
EPT Cobra	38U/38Q	3.75	2.38	3.38	4.50	6.81	1.625	7.84	1.000	7.25
Leeson	B638/BMQ638	3.75	2.38	4.25	3.88	7.75	1.625	8.38	1.000	7.06

\* - for 180 frame

\*\* - Dimension shown is for the Reduced Diameter Shaft Option

Manufacturer	Unit	CD	E	F	J	P	W Dia.	M	U Dia.	M1*
Series B	B111W/B111WM	3.54	2.00	3.75	3.39	7.75	1.875	8.39	1.188	8.50
Winsmith	943MDN/943DN	4.25	1.63	3.75	4.38	8.00	2.000	8.19	1.250	6.63
Alling-Lander	42U/42UF	4.25	1.88	3.75	4.50	7.50	1.750	9.57	1.250	7.21
Ohio	B2425/BMC2425	4.25	2.50	4.75	4.44	8.06	1.750	9.56	1.125	7.21
Grove - Old	B242/BMQ242	4.25	2.50	4.25	4.44	8.12	1.875	9.57	1.250	7.21
Grove - New	B242/BMQ242	4.25	2.50	4.25	4.44	8.12	1.875	9.57	1.250	6.45
Falk - Omni Box	425WB/425WBM	4.25	2.50	4.25	4.44	8.12	1.875	9.57	1.250	7.21
Grove - OE	42U/42UF	4.25	1.88	3.75	4.50	7.50	1.750	9.57	1.250	7.21

\* - for 180 frame

## Units with Horizontal Base

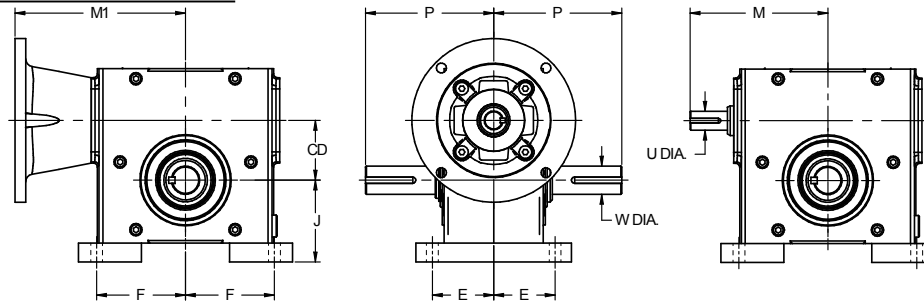

Manufacturer	Unit	CD	E	F	J	P	W Dia.	M	U Dia.	M1*
Series B	B021B/B021BM	1.33	1.66	2.19	2.25	4.00	0.625 **	4.22	0.625	4.74
Perfection-Predator	U13/UC13	1.33	1.66	2.19	2.25	4.00	0.625	3.80	0.500	3.38
Boston	F713B/713B	1.33	1.66	2.19	2.25	4.00	0.625	3.91	0.500	3.94
Grove - Old	TMQ1133/T1133	1.33	1.66	2.19	2.25	3.99	0.625	4.45	0.500	3.46
Grove - New	TMQ213/T213	1.33	1.66	2.19	2.25	4.00	0.625	3.82	0.500	3.46
Falk Omni Box	133WOMCT/133WO	1.33	1.66	2.19	2.25	3.99	0.625	4.45	0.500	3.46
Sterling	133AQ/133AR	1.33	1.66	2.19	2.25	3.99	0.625	4.45	0.500	3.46
Ohio	133MQ/133B	1.33	1.66	2.19	2.25	4.00	0.625	3.69	0.500	3.96
EPT - Raider	133QT/133UT	1.33	1.66	2.19	2.25	4.00	0.625	4.03	0.500	3.94
Baldor	F913/S913	1.33	1.66	2.19	2.25	4.00	0.625	3.91	0.500	3.94
Leeson	T613/TMQ613	1.33	1.66	2.19	2.25	4.00	0.625	3.82	0.500	3.42
Dodge/Tigear	Q133/S133	1.33	1.66	2.19	2.25	4.00	0.625	3.90	0.625	3.72

\* - for 56C frame

\*\* - Dimension shown is for the Reduced Diameter Shaft Option

Manufacturer	Unit	CD	E	F	J	P	W Dia.	M	U Dia.	M1*
Series B	B031B/B031BM	1.54	2.16	2.63	2.50	4.31	0.750	4.87	0.750	5.92
Boston	F715B/715B	1.54	2.16	2.63	2.50	4.31	0.750	4.69	0.625	4.50
Grove - Old	TMQ1154/T1154	1.54	2.16	2.62	2.50	4.31	0.750	4.91	0.625	3.99
Grove - New	TMQ215/T215	1.54	2.16	2.63	2.50	4.31	0.750	4.35	0.625	3.99
EPT - Raider	154QT/154UT	1.54	2.16	2.63	2.50	4.31	0.750	4.69	0.625	4.52
Dodge/Tigear	Q150/S150	1.50	2.16	2.63	2.49	4.00	0.750	5.62	0.625	4.44
Winsmith	917MDN/917DN	1.75	2.16	2.63	2.50	4.75	1.000	4.75	0.750	4.06

\* - for a NEMA 56C frame

Manufacturer	Unit	CD	E	F	J	P	W Dia.	M	U Dia.	M1*
Series B	B041B/B041BM	1.75	2.25	2.88	2.75	4.31	0.875 **	5.13	0.750	6.18
Perfection-Predator	U18/UC18	1.75	2.25	2.88	2.75	4.31	0.875	4.75	0.625	4.04
Boston	F718B/718B	1.75	2.25	2.88	2.75	4.31	0.875	4.88	0.625	4.69
Grove - Old	BMQ1175/B1175	1.75	2.25	2.88	2.75	4.31	0.875	5.08	0.625	4.09
Grove - New	TMQ218/T218	1.75	2.25	2.88	2.75	4.31	0.875	4.45	0.625	4.09
Falk Omni Box	175WUM/175WU	1.75	2.25	2.88	2.75	4.31	0.875	5.08	0.625	4.09
Sterling	175AQ/175AR	1.75	2.25	2.88	2.75	4.31	0.875	5.08	0.625	4.09
Ohio	175MQ/175U	1.75	2.25	2.88	2.75	4.31	0.875	4.75	0.625	4.44
EPT - Raider	175QT/175UT	1.75	2.25	2.88	2.75	4.31	0.875	4.68	0.625	4.38
Baldor	F918/S918	1.75	2.25	2.88	2.75	4.31	0.875	4.88	0.625	4.69
Leeson	T618/TMQ618	1.75	2.25	2.88	2.75	4.31	0.875	4.44	0.625	3.99
Dodge/Tigear	Q175/S175	1.75	2.25	2.88	2.75	4.31	0.875	4.75	0.625	4.94

\* - for 56C frame

\*\* - Dimension shown is for the Reduced Diameter Shaft Option

Manufacturer	Unit	CD	E	F	J	P	W Dia.	M	U Dia.	M1*
Series B	B051B/B051BM	1.97	2.34	3.19	3.00	4.69	1.000 **	5.20	0.750	6.34
Perfection-Predator	U21/UC21	2.06	2.34	3.19	3.00	4.69	1.000	5.13	0.625	4.35
Boston	F721B/721B	2.06	2.34	3.19	3.00	4.69	1.000	5.13	0.625	5.06
Grove - Old	TMQ1206/T1206	2.06	2.34	3.19	3.00	4.68	1.000	5.45	0.625	4.46
Grove - New	TMQ220/T220	2.06	2.34	3.19	3.00	4.68	1.000	4.82	0.625	4.46
Falk Omni Box	206WOM/206WO	2.06	2.34	3.19	3.00	4.68	1.000	5.45	0.625	4.46
Sterling	206AQ/206AR	2.06	2.34	3.19	3.00	4.68	1.000	5.45	0.625	4.46
Ohio	206MQ/206B	2.06	2.34	3.19	3.00	4.69	1.000	5.16	0.625	4.75
EPT - Raider	206QT/206UT	2.06	2.34	3.19	3.00	4.69	1.000	5.06	0.625	4.75
Baldor	F921/S921	2.06	2.34	3.19	3.00	4.69	1.000	4.85	0.625	4.40
Leeson	T621/TMQ621	2.06	2.34	3.19	3.00	4.68	1.000	4.85	0.625	4.40
Dodge/Tigear	Q200/S200	2.06	2.34	3.19	3.00	4.69	1.000	5.12	0.625	5.00

\* - for 56C/143TC frames

\*\* - Dimension shown is for the Reduced Diameter Shaft Option

## Units with Horizontal Base (Continued)

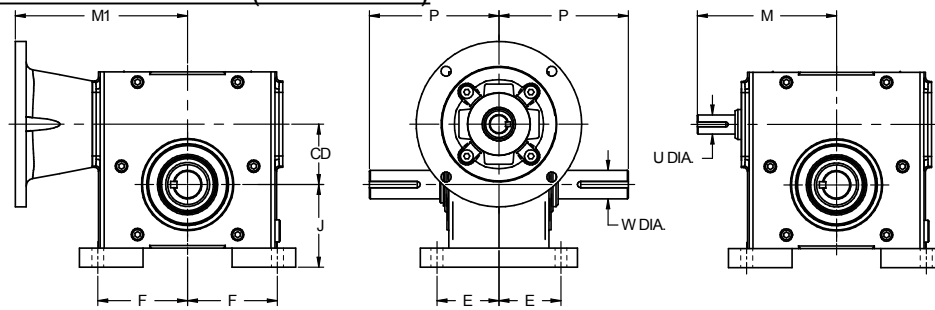

Manufacturer	Unit	CD	E	F	J	P	W Dia.	M	U Dia.	M1*
Series B	B061B/B061BM	2.38	2.44	3.53	3.25	5.09	1.125	5.47	0.750	6.77
Perfection-Predator	U24/UC24	2.38	2.44	3.53	2.50	5.09	1.125	5.75	0.750	4.75
Boston	F724B/724B	2.38	2.44	3.53	3.25	5.09	1.125	5.75	0.750	5.25
Grove - Old	TMQ1238/T1238	2.38	2.44	3.53	3.25	5.14	1.125	6.05	0.750	4.63
Grove - New	TMQ224/T224	2.38	2.44	3.53	3.25	5.14	1.125	5.51	0.750	4.63
Falk Omni Box	238WOM/238WO	2.38	2.44	3.53	3.25	5.14	1.125	6.05	0.750	4.63
Sterling	238AQ/238AR	2.38	2.44	3.53	3.25	5.14	1.125	6.05	0.750	4.63
Ohio	238MQ/238B	2.38	2.44	3.53	3.25	5.09	1.125	5.81	0.750	5.25
EPT - Raider	238Q/238U	2.38	2.44	3.53	3.25	5.08	1.125	5.44	0.750	5.06
Baldor	F924/S924	2.38	2.44	3.53	3.25	5.09	1.125	5.51	0.750	4.63
Leeson	T624/TMQ624	2.38	2.44	3.53	3.25	5.09	1.125	5.51	0.750	4.63

\* - for 56C/143TC frames

Manufacturer	Unit	CD	E	F	J	P	W Dia.	M	U Dia.	M1*
Series B	B081B/B081BM	2.625	2.63	4.00	3.69	5.63	1.125 **	7.23	1.188	7.24
Perfection-Predator	U26/UC26	2.625	2.63	4.00	3.69	5.63	1.125	6.31	0.750	5.48
Boston	F726B/726B	2.625	2.63	4.00	3.69	5.63	1.125	6.31	0.750	5.75
Grove - Old	TMQ1262/T1262	2.625	2.63	4.00	3.69	5.63	1.250	6.57	0.750	5.19
Grove - New	TMQ226/T226	2.625	2.63	4.00	3.69	5.63	1.250	6.07	0.750	5.19
Falk Omni Box	262WOM/262WO	2.625	2.63	4.00	3.69	5.63	1.250	6.57	0.750	5.19
Sterling	262AQ/262AR	2.625	2.63	4.00	3.69	5.63	1.250	6.57	0.750	5.19
Ohio	262MQ/262B	2.625	2.63	4.00	3.69	5.63	1.125	6.31	0.750	5.62
EPT - Raider	262QT/262UT	2.625	2.63	4.00	3.69	5.63	1.125	6.23	0.750	5.69
Baldor	F926/S926	2.625	2.63	4.00	3.69	5.62	1.125	6.31	0.750	5.75
Leeson	T626/BTQ626	2.625	2.63	4.00	3.69	5.63	1.125	6.11	0.750	5.23
Dodge/Tigear	262	2.625	2.63	4.00	3.69	5.63	1.125	6.32	0.750	6.63

\* - for 56C/143 TC frame

\*\* - Dimension shown is for the Reduced Diameter Shaft Option

Manufacturer	Unit	CD	E	F	J	P	W Dia.	M	U Dia.	M1*
Series B	B091B/B091BM	3.00	2.94	4.22	4.00	6.75	1.250 **	7.63	1.188	7.64
Grove - Old	TMQ1300/T1300	3.00	2.94	4.22	4.00	6.75	1.250	7.25	0.875	5.69
Grove - New	TMQ230/T230	3.00	2.94	4.22	4.00	6.75	1.250	6.57	0.875	5.69
Falk Omni Box	300WOM/300WO	3.00	2.94	4.22	4.00	6.75	1.250	7.25	0.875	5.69
Sterling	300AQ/300AR	3.00	2.94	4.22	4.00	6.75	1.250	7.25	0.875	5.69
Ohio	300MQ/300B	3.00	2.94	4.22	4.00	6.75	1.250	7.50	0.875	6.25
EPT - Raider	300QT/300UT	3.00	2.94	4.22	4.13	6.75	1.250	7.50	0.875	6.25

\* - for 56C/143 TC frame

\*\* - Dimension shown is for the Reduced Diameter Shaft Option

Manufacturer	Unit	CD	E	F	J	P	W Dia.	M	U Dia.	M1*
Series B	B101B/B101BM	3.25	3.06	4.75	4.38	7.06	1.375 **	7.64	1.188	7.72
Perfection-Modular	H32/HG32	3.25	3.06	4.75	4.38	5.44	1.250	6.88	0.875	5.60
Perfection-Predator	U32/UG32	3.25	3.06	4.75	4.38	7.06	1.375	7.44	0.875	6.22
Boston	F732/732B	3.25	3.06	4.75	4.38	7.06	1.375	7.44	0.875	7.00
Grove - Old	TMQ232/T232	3.25	3.06	4.75	4.38	7.06	1.500	6.76	0.875	6.31
Grove - New	TMQ230/T230	3.25	3.06	4.75	4.38	7.06	1.500	6.76	0.875	5.88
Falk Omni Box	300WOM/300WO	3.25	3.06	4.75	4.38	7.06	1.500	6.76	0.875	6.31
Sterling	300AQ/300AR	3.25	3.06	4.75	4.38	7.06	1.500	6.76	0.875	6.31
Baldor	F932/S932	3.25	3.06	4.75	4.38	7.06	1.375	7.44	0.875	7.00
Leeson	T623/TMQ632	3.25	3.06	4.75	4.38	7.06	1.375	7.44	0.875	6.56
EPT - Raider	325UT/325U	3.25	3.06	4.75	4.38	7.06	1.375	7.06	0.875	7.00
Ohio	325MQ/325U	3.25	3.06	4.75	4.38	7.06	1.375	7.19	0.875	6.47
Winsmith	930MDN/930DN	3.00	3.06	4.75	4.38	5.88	1.375	7.00	1.000	5.56

\* - for 180 frame

\*\* - Dimension shown is for the Reduced Diameter Shaft Option

## Units with Horizontal Base (Continued)

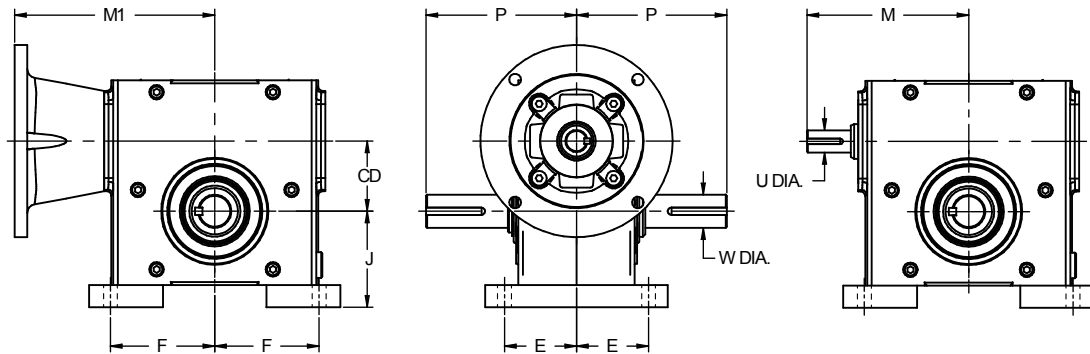

Manufacturer	Unit	CD	E	F	J	P	W Dia.	M	U Dia.	M1*
Series B	B111B/B111BM	3.54	3.06	4.75	5.00	7.75	1.625 **	8.39	1.188	8.50
Dodge/Tigear	350	3.50	3.06	4.75	5.00	7.06	1.500	7.19	0.875	7.41

\* - for 180 frame

\*\* - Dimension shown is for the Reduced Diameter Shaft Option

Manufacturer	Unit	CD	E	F	J	P	W Dia.	M	U Dia.	M1*
Series B	B111B/B111BM	3.54	3.06	4.75	5.00	7.75	1.625 **	8.39	1.188	8.50
Perfection-Modular	H38/HG38	3.75	3.50	5.19	4.81	6.69	1.500	7.50	1.000	6.10
Hub City	381/384	3.75	2.53	3.94	4.77	6.69	1.500	7.50	1.000	6.63
Perfection-Predator	U38/UG38	3.75	3.50	5.19	4.81	7.75	1.625	8.38	1.000	6.73
Boston	F738B/738B	3.75	3.50	5.19	4.81	7.75	1.625	8.38	1.000	7.50
EPT-Raider	375U/375Q	3.75	3.50	5.19	4.81	7.75	1.625	7.84	1.000	7.29
EPT Cobra	38U/38Q	3.75	2.38	3.38	4.50	6.81	1.625	7.84	1.000	7.25
Winsmith	935MDN/935/DN	3.50	3.50	5.19	4.81	7.00	1.750	7.38	1.000	5.81
Leeson	T638/TMQ638	3.75	3.50	5.19	4.81	7.75	1.625	8.38	1.000	7.06

\* - for 180 frame

\*\* - Dimension shown is for the Reduced Diameter Shaft Option

Manufacturer	Unit	CD	E	F	J	P	W Dia.	M	U Dia.	M1*
Series B	B111B/B111BM	3.54	3.06	4.75	5.00	7.75	1.875	8.39	1.188	8.50
Winsmith	943MDN/943DN	4.25	2.88	4.88	5.00	8.00	2.000	8.19	1.250	6.63
Alling-Lander	42Z/42ZF	4.25	2.88	4.88	5.00	7.50	1.750	9.57	1.250	7.21
Ohio	UMQ2425U2425	4.25	3.75	6.13	5.44	8.06	1.750	9.56	1.125	7.21
Grove - Old	T242/TMQ242	4.25	3.81	5.56	5.44	8.12	1.875	9.57	1.250	7.21
Grove - New	T242/TMQ242	4.25	3.81	5.56	5.44	8.12	1.875	9.57	1.250	6.45
Falk - Omni Box	425WB/425WBM	4.25	3.81	5.56	5.44	8.12	1.875	9.57	1.250	7.21
Grove - OE	42Z/42ZF	4.25	2.88	4.88	5.00	7.50	1.750	9.57	1.250	7.21

\* - for 180 frame



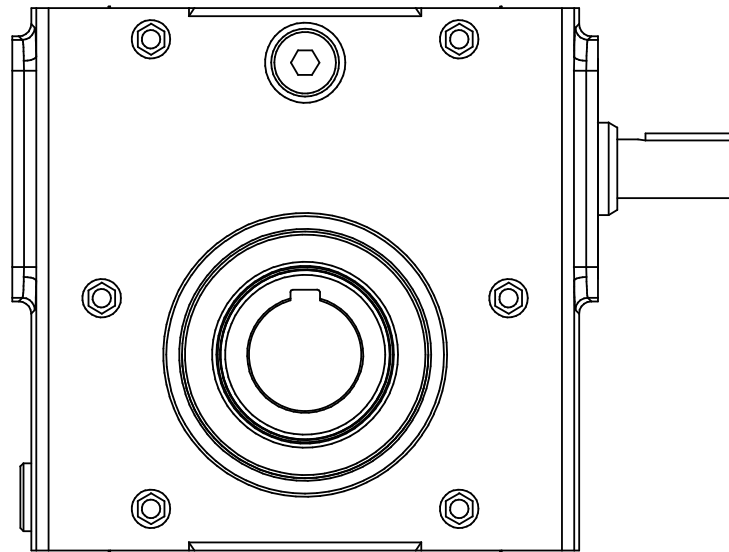

REDUCER

**SERIES B**

## Overhung Loads (Lbs) On Shafts

### Maximum permissible overhung loads

When a sprocket, gear etc. is mounted on the shaft a calculation, as below, must be made to determine the overhung load on the shaft, and the results compared to the maximum permissible overhung loads tabulated. Overhung loads can be reduced by increasing the diameter of the sprocket, gear, etc. If the maximum permissible overhung load is exceeded, the sprocket, gear, etc. should be mounted on a separate shaft, flexibly coupled and supported in its own bearings, or the gear unit shaft should be extended to run in an outboard bearing. Alternatively, a larger gear is often a less expensive solution.

Permissible overhung loads vary according to the direction of rotation. The values tabulated are for the most unfavorable direction with the unit transmitting full rated power and the load P applied midway along the output shaft key. Hence they can sometimes be increased for a more favourable direction of rotation, or if the power transmitted is less than the rated capacity of the gear unit, or if the load is applied nearer to the gear unit case. Refer to our Application Engineers for further details. In any event, the sprocket, gear etc. should be positioned as close as possible to the gear unit case in order to reduce bearing loads and shaft stresses, and to prolong life. All units will accept 100% momentary overload on stated capacities.

### Overhung load (lbs)

$$P = \frac{HP \times 126,000 \times K}{N \times D}$$

- P = equivalent overhung load (lb)  
 HP = power transmitted by the shaft (HP)  
 N = speed of shaft (RPM)  
 D = pitch diameter of sprocket, etc. (in)  
 K = factor

Note: 1 lb = 4.448 N = 0.454 kg

### Overhung member

Overhung member	K (factor)
Chain sprocket*	1.00
Spur or helical pinion	1.25
Vee belt sheave	1.50
Flat belt pulley	2.00

\* If multistrand chain drives are equally loaded and the outer strand is further than dimension A output, contact our Application Engineers.

### Distance midway along output shaft key

Size of Unit	Dimension A (Inches)
B02	0.50
B03	0.57
B04	0.63
B05	0.75
B06	0.94
B08	0.97
B09	1.00
B10	1.13
B11	1.32

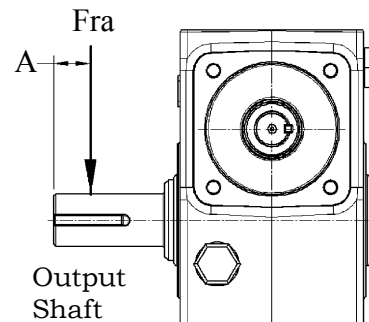

### OUTPUT SHAFT OVERHUNG LOAD RATINGS (LBS)

B0210	B0310	B0410	B0510	B0610	B0810	B0910	B1010	B1110
400	475	710	875	1100	1200	1550	2000	2200

# Series B

# Reducer Ratings - Single Reduction

## Single Reduction - Ratings At 1750 RPM Input

RATIO	Output Speed REV/ MIN	CAPACITY	SIZES OF UNIT								
			B02	B03	B04	B05	B06	B08	B09	B10	B11
5	350	Input Power HP (mech)	1.76	2.51	3.45	4.62	7.47	9.62	13.57	16.58	20.63
		Input Power HP (therm)	1.97	2.76	4.38	5.07	7.51	10.58	12.75	16.45	17.59
		Output Torque lb-in (mech)	275	401	559	757	1242	1609	2284	2801	3495
		Efficiency	0.87	0.89	0.90	0.91	0.92	0.93	0.93	0.94	0.94
7.5	233	Input Power HP (mech)	1.30	1.85	2.54	3.39	5.45	6.97	9.76	11.88	14.73
		Input Power HP (therm)	1.64	2.27	3.56	4.12	6.08	8.55	10.31	13.29	14.24
		Output Torque lb-in (mech)	296	433	603	818	1337	1723	2433	2974	3699
		Efficiency	0.84	0.86	0.88	0.89	0.91	0.92	0.92	0.93	0.93
10	175	Input Power HP (mech)	1.05	1.47	1.84	2.63	4.17	4.98	6.99	8.93	11.05
		Input Power HP (therm)	1.45	2.00	3.12	3.60	5.32	7.47	9.01	11.61	12.45
		Output Torque lb-in (mech)	308	446	570	830	1342	1618	2294	2945	3660
		Efficiency	0.82	0.84	0.86	0.88	0.89	0.90	0.91	0.92	0.92
15	117	Input Power HP (mech)	0.79	1.11	1.51	2.02	3.26	4.13	5.79	7.18	8.93
		Input Power HP (therm)	1.10	1.50	2.32	2.68	3.93	5.50	6.63	8.53	9.15
		Output Torque lb-in (mech)	325	479	674	919	1524	1952	2772	3461	4333
		Efficiency	0.76	0.80	0.82	0.84	0.87	0.88	0.89	0.89	0.90
20	88	Input Power HP (mech)	0.62	0.88	1.20	1.60	2.59	3.34	4.70	5.74	7.15
		Input Power HP (therm)	0.87	1.18	1.80	2.08	3.03	4.23	5.09	6.53	7.00
		Output Torque lb-in (mech)	319	476	675	927	1553	2026	2900	3572	4479
		Efficiency	0.71	0.75	0.78	0.80	0.83	0.84	0.86	0.86	0.87
25	70	Input Power HP (mech)	0.56	0.79	1.08	1.44	2.32	2.72	3.81	4.65	5.76
		Input Power HP (therm)	0.74	0.99	1.51	1.74	2.53	3.47	4.16	5.33	5.71
		Output Torque lb-in (mech)	340	510	726	1001	1682	1989	2838	3491	4370
		Efficiency	0.67	0.72	0.75	0.77	0.80	0.81	0.83	0.83	0.84
30	58	Input Power HP (mech)	0.49	0.67	0.90	1.20	1.91	2.45	3.43	4.18	5.20
		Input Power HP (therm)	0.67	0.90	1.37	1.57	2.28	3.16	3.79	4.86	5.20
		Output Torque lb-in (mech)	332	494	700	961	1610	2100	3005	3702	4645
		Efficiency	0.63	0.68	0.72	0.74	0.78	0.79	0.81	0.82	0.83
40	44	Input Power HP (mech)	0.38	0.51	0.68	0.89	1.41	1.79	2.49	3.03	3.75
		Input Power HP (therm)	0.54	0.72	1.08	1.23	1.78	2.45	2.93	3.74	4.00
		Output Torque lb-in (mech)	298	444	630	866	1450	1892	2708	3337	4185
		Efficiency	0.55	0.60	0.64	0.67	0.72	0.73	0.75	0.76	0.77
50	35	Input Power HP (mech)	0.33	0.44	0.58	0.75	1.16	1.46	2.01	2.43	2.99
		Input Power HP (therm)	0.47	0.62	0.92	1.04	1.49	2.05	2.44	3.11	3.32
		Output Torque lb-in (mech)	291	434	610	832	1381	1794	2554	3137	3921
		Efficiency	0.49	0.54	0.58	0.62	0.66	0.68	0.70	0.72	0.73
60	29	Input Power HP (mech)	0.29	0.38	0.50	0.64	0.98	1.24	1.70	2.05	2.52
		Input Power HP (therm)	0.42	0.55	0.81	0.92	1.31	1.79	2.13	2.70	2.88
		Output Torque lb-in (mech)	272	404	570	782	1305	1699	2427	2986	3739
		Efficiency	0.43	0.49	0.53	0.57	0.61	0.64	0.66	0.67	0.69

NOTE: Thermal rating for units driven by fan cooled motor.

Ratings assumes units are fitted with standard output shafts

# Series B

# Reducer Ratings - Double Reduction

## Double Reduction - Ratings At 1750 RPM Input

RATIO	Output Speed	CAPACITY	SIZES OF UNIT					
			B0520	B0620	B0820	B0920	B1020	B1120
100	18	Input Power HP (mech)	0.59	0.98	1.23	1.73	2.10	2.61
		Output Torque lb-in (mech)	1429	2400	3134	4494	5542	6959
		Full Load Efficiency	0.67	0.68	0.71	0.72	0.73	0.74
150	12	Input Power HP (mech.)	0.46	0.75	0.93	1.32	1.59	1.98
		Output Torque lb-in (mech.)	1546	2598	3393	4868	6004	7540
		Full Load Efficiency	0.62	0.64	0.67	0.68	0.70	0.71
200	8.8	Input Power HP (mech.)	0.36	0.60	0.73	1.03	1.24	1.54
		Output Torque lb-in (mech.)	1546	2598	3393	4868	6004	7540
		Full Load Efficiency	0.59	0.61	0.65	0.66	0.67	0.68
300	5.8	Input Power HP (mech.)	0.27	0.44	0.53	0.74	0.89	1.11
		Output Torque lb-in (mech.)	1546	2598	3393	4868	6004	7540
		Full Load Efficiency	0.54	0.55	0.60	0.61	0.62	0.63
400	4.4	Input Power HP (mech.)	0.22	0.36	0.43	0.60	0.72	0.89
		Output Torque lb-in (mech.)	1546	2598	3393	4868	6004	7540
		Full Load Efficiency	0.49	0.50	0.55	0.56	0.58	0.59
500	3.5	Input Power HP (mech)	0.18	0.30	0.35	0.50	0.59	0.74
		Output Torque lb-in (mech)	1546	2598	3393	4868	6004	7540
		Full Load Efficiency	0.46	0.48	0.53	0.54	0.56	0.57
600	2.9	Input Power HP (mech.)	0.17	0.28	0.32	0.45	0.53	0.66
		Output Torque lb-in (mech.)	1546	2598	3393	4868	6004	7540
		Full Load Efficiency	0.43	0.44	0.49	0.50	0.52	0.53
800	2.2	Input Power HP (mech.)	0.15	0.24	0.27	0.38	0.45	0.55
		Output Torque lb-in (mech.)	1546	2598	3393	4868	6004	7540
		Full Load Efficiency	0.37	0.37	0.44	0.44	0.47	0.47
1000	1.8	Input Power HP (mech.)	0.13	0.22	0.24	0.34	0.39	0.49
		Output Torque lb-in (mech.)	1546	2598	3393	4868	6004	7540
		Full Load Efficiency	0.32	0.33	0.39	0.40	0.42	0.43
1200	1.5	Input Power HP (mech.)	0.13	0.21	0.22	0.31	0.36	0.45
		Output Torque lb-in (mech.)	1546	2598	3393	4868	6004	7540
		Full Load Efficiency	0.29	0.29	0.35	0.36	0.38	0.39
1500	1.2	Input Power HP (mech.)	0.08	0.13	0.15	0.21	0.25	0.30
		Output Torque lb-in (mech.)	1237	2069	2699	3863	4760	5969
		Full Load Efficiency	0.28	0.29	0.33	0.34	0.36	0.36
1800	1.0	Input Power HP (mech.)	0.08	0.12	0.14	0.19	0.23	0.28
		Output Torque lb-in (mech.)	1237	2069	2699	3863	4760	5969
		Full Load Efficiency	0.25	0.26	0.30	0.31	0.33	0.33
2400	0.7	Input Power HP (mech.)	0.07	0.11	0.12	0.17	0.19	0.24
		Output Torque lb-in (mech.)	1237	2069	2699	3863	4760	5969
		Full Load Efficiency	0.21	0.22	0.26	0.27	0.29	0.29
3000	0.6	Input Power HP (mech.)	0.06	0.10	0.11	0.15	0.17	0.21
		Output Torque lb-in (mech.)	1237	2069	2699	3863	4760	5969
		Full Load Efficiency	0.19	0.19	0.23	0.24	0.26	0.26
3600	0.5	Input Power HP (mech.)	0.06	0.09	0.10	0.14	0.16	0.20
		Output Torque lb-in (mech.)	1237	2069	2699	3863	4760	5969
		Full Load Efficiency	0.16	0.17	0.21	0.21	0.23	0.23

NOTE: Ratings assumes units are fitted with standard output shafts

# Series B

# Reducer Ratings - Single Reduction

## Single Reduction - Ratings At 1150 RPM Input

RATIO	Output Speed REV/ MIN	CAPACITY	SIZES OF UNIT								
			B02	B03	B04	B05	B06	B08	B09	B10	B11
5	230	Input Power HP (mech)	1.33	1.91	2.63	3.53	5.73	7.39	10.43	12.76	15.88
		Input Power HP (therm)	2.26	3.00	4.46	5.12	7.37	10.14	12.19	15.54	16.69
		Output Torque lb-in (mech)	320	468	652	883	1451	1880	2671	3276	4091
		Efficiency	0.88	0.89	0.90	0.91	0.92	0.93	0.93	0.94	0.94
7.5	153	Input Power HP (mech)	0.97	1.39	1.91	2.57	4.14	5.30	7.43	9.05	11.22
		Input Power HP (therm)	1.82	2.41	3.57	4.10	5.91	8.13	9.78	12.48	13.42
		Output Torque lb-in (mech)	341	499	696	944	1544	1991	2812	3439	4279
		Efficiency	0.85	0.87	0.88	0.89	0.91	0.91	0.92	0.92	0.93
10	115	Input Power HP (mech)	0.78	0.98	1.20	1.84	2.79	3.27	4.60	6.76	8.37
		Input Power HP (therm)	1.59	2.10	3.10	3.56	5.13	7.06	8.50	10.84	11.66
		Output Torque lb-in (mech)	353	455	571	883	1367	1616	2290	3381	4203
		Efficiency	0.83	0.85	0.87	0.88	0.89	0.90	0.91	0.91	0.92
15	77	Input Power HP (mech)	0.58	0.82	1.01	1.51	2.32	2.72	3.82	5.41	6.73
		Input Power HP (therm)	1.18	1.56	2.29	2.63	3.78	5.19	6.25	7.96	8.57
		Output Torque lb-in (mech)	369	543	684	1045	1645	1947	2765	3941	4935
		Efficiency	0.78	0.81	0.83	0.84	0.86	0.87	0.88	0.89	0.89
20	58	Input Power HP (mech)	0.46	0.65	0.89	1.20	1.94	2.50	3.53	4.32	5.38
		Input Power HP (therm)	0.93	1.22	1.78	2.04	2.92	4.00	4.80	6.11	6.57
		Output Torque lb-in (mech)	360	538	763	1049	1758	2294	3285	4048	5078
		Efficiency	0.72	0.76	0.78	0.80	0.83	0.84	0.85	0.86	0.86
25	46	Input Power HP (mech)	0.41	0.58	0.80	1.07	1.74	2.04	2.86	3.49	4.33
		Input Power HP (therm)	0.78	1.02	1.49	1.71	2.44	3.29	3.94	5.00	5.37
		Output Torque lb-in (mech)	383	574	818	1128	1897	2244	3205	3943	4937
		Efficiency	0.68	0.72	0.75	0.77	0.80	0.80	0.82	0.82	0.83
30	38	Input Power HP (mech)	0.35	0.49	0.67	0.89	1.43	1.78	2.49	3.14	3.90
		Input Power HP (therm)	0.71	0.93	1.35	1.54	2.19	2.99	3.59	4.55	4.89
		Output Torque lb-in (mech)	373	555	786	1081	1811	2300	3269	4169	5233
		Efficiency	0.65	0.69	0.72	0.74	0.77	0.78	0.80	0.81	0.82
40	29	Input Power HP (mech)	0.27	0.37	0.50	0.66	1.05	1.34	1.87	2.27	2.82
		Input Power HP (therm)	0.57	0.74	1.07	1.22	1.72	2.33	2.79	3.53	3.78
		Output Torque lb-in (mech)	333	497	705	969	1626	2121	3038	3744	4698
		Efficiency	0.56	0.61	0.64	0.67	0.71	0.72	0.74	0.75	0.76
50	23	Input Power HP (mech)	0.24	0.32	0.42	0.55	0.86	1.09	1.51	1.83	2.25
		Input Power HP (therm)	0.49	0.63	0.91	1.03	1.45	1.96	2.33	2.94	3.15
		Output Torque lb-in (mech)	325	484	681	930	1544	2006	2857	3511	4390
		Efficiency	0.50	0.55	0.58	0.61	0.65	0.67	0.69	0.70	0.71
60	19	Input Power HP (mech)	0.21	0.28	0.36	0.47	0.73	0.92	1.27	1.54	1.90
		Input Power HP (therm)	0.44	0.56	0.80	0.91	1.27	1.71	2.03	2.56	2.74
		Output Torque lb-in (mech)	303	450	636	872	1455	1896	2710	3335	4178
		Efficiency	0.45	0.50	0.53	0.56	0.60	0.62	0.65	0.66	0.67

NOTE: Thermal rating for units driven by fan cooled motor.

Ratings assumes units are fitted with standard output shafts

# Series B

# Reducer Ratings - Double Reduction

## Double Reduction - Ratings At 1150 RPM Input

RATIO	Output Speed	CAPACITY	SIZES OF UNIT					
			B0520	B0620	B0820	B0920	B1020	B1120
100	12	Input Power HP (mech)	0.43	0.71	0.89	1.26	1.53	1.91
		Output Torque lb-in (mech)	1546	2598	3393	4868	6004	7540
		Full Load Efficiency	0.65	0.67	0.69	0.70	0.72	0.72
150	7.7	Input Power HP (mech.)	0.31	0.51	0.63	0.89	1.08	1.34
		Output Torque lb-in (mech.)	1546	2598	3393	4868	6004	7540
		Full Load Efficiency	0.61	0.62	0.66	0.66	0.68	0.68
200	5.8	Input Power HP (mech.)	0.24	0.40	0.49	0.70	0.84	1.05
		Output Torque lb-in (mech.)	1546	2598	3393	4868	6004	7540
		Full Load Efficiency	0.58	0.59	0.63	0.64	0.65	0.66
300	3.8	Input Power HP (mech.)	0.18	0.29	0.36	0.51	0.61	0.76
		Output Torque lb-in (mech.)	1546	2598	3393	4868	6004	7540
		Full Load Efficiency	0.53	0.54	0.58	0.59	0.60	0.61
400	2.9	Input Power HP (mech.)	0.15	0.24	0.29	0.41	0.49	0.61
		Output Torque lb-in (mech.)	1546	2598	3393	4868	6004	7540
		Full Load Efficiency	0.48	0.49	0.53	0.54	0.56	0.56
500	2.3	Input Power HP (mech)	0.12	0.20	0.24	0.34	0.41	0.51
		Output Torque lb-in (mech)	1546	2598	3393	4868	6004	7540
		Full Load Efficiency	0.46	0.47	0.51	0.52	0.54	0.54
600	1.9	Input Power HP (mech.)	0.11	0.18	0.22	0.31	0.36	0.46
		Output Torque lb-in (mech.)	1546	2598	3393	4868	6004	7540
		Full Load Efficiency	0.42	0.43	0.48	0.48	0.50	0.50
800	1.4	Input Power HP (mech.)	0.10	0.16	0.18	0.26	0.31	0.38
		Output Torque lb-in (mech.)	1546	2598	3393	4868	6004	7540
		Full Load Efficiency	0.36	0.37	0.42	0.43	0.45	0.45
1000	1.2	Input Power HP (mech.)	0.09	0.14	0.16	0.23	0.27	0.34
		Output Torque lb-in (mech.)	1546	2598	3393	4868	6004	7540
		Full Load Efficiency	0.32	0.33	0.38	0.39	0.41	0.41
1200	1.0	Input Power HP (mech.)	0.08	0.14	0.15	0.21	0.25	0.31
		Output Torque lb-in (mech.)	1546	2598	3393	4868	6004	7540
		Full Load Efficiency	0.28	0.29	0.34	0.35	0.37	0.37
1500	0.8	Input Power HP (mech.)	0.06	0.09	0.11	0.15	0.18	0.22
		Output Torque lb-in (mech.)	1237	2069	2699	3863	4760	5969
		Full Load Efficiency	0.27	0.28	0.31	0.32	0.33	0.33
1800	0.6	Input Power HP (mech.)	0.05	0.08	0.10	0.14	0.16	0.20
		Output Torque lb-in (mech.)	1237	2069	2699	3863	4760	5969
		Full Load Efficiency	0.24	0.25	0.28	0.29	0.30	0.30
2400	0.5	Input Power HP (mech.)	0.05	0.07	0.08	0.12	0.14	0.17
		Output Torque lb-in (mech.)	1237	2069	2699	3863	4760	5969
		Full Load Efficiency	0.21	0.21	0.25	0.25	0.27	0.27
3000	0.4	Input Power HP (mech.)	0.04	0.07	0.07	0.10	0.12	0.15
		Output Torque lb-in (mech.)	1237	2069	2699	3863	4760	5969
		Full Load Efficiency	0.18	0.19	0.22	0.22	0.24	0.24
3600	0.3	Input Power HP (mech.)	0.04	0.06	0.07	0.10	0.11	0.14
		Output Torque lb-in (mech.)	1237	2069	2699	3863	4760	5969
		Full Load Efficiency	0.16	0.16	0.20	0.20	0.22	0.22

NOTE: Ratings assumes units are fitted with standard output shafts

# Series B

# Reducer Dimensions - Single Reduction Units

## Standard Unit

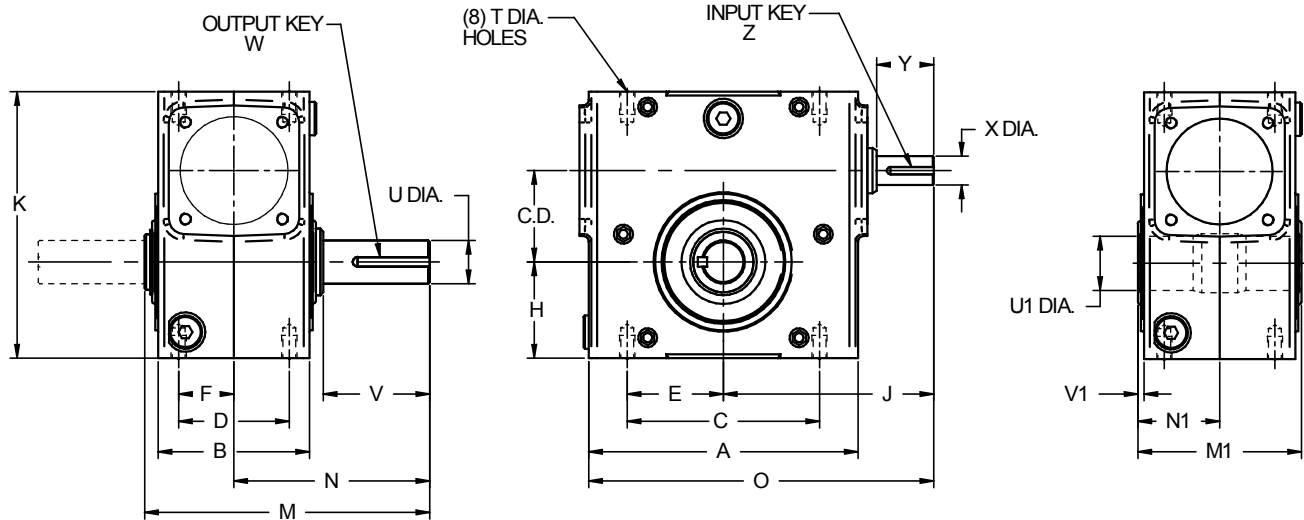

Case Size	C.D.	A	B	C	D	E	F	H	J	K	M	M1	N	N1	O
B02	1.33	4.33	2.76	3.25	2.00	1.63	1.00	1.72	4.22	4.66	6.10	3.85	4.00	1.93	6.38
B03	1.54	5.23	3.94	4.19	2.75	2.10	1.38	1.91	4.87	5.35	6.61	4.25	4.31	2.12	7.55
B04	1.75	5.98	3.94	4.19	2.75	2.10	1.38	2.06	5.13	5.75	6.65	4.29	4.31	2.15	8.19
B05	1.97	6.00	3.94	5.00	2.88	2.50	1.44	2.28	5.20	6.38	7.00	4.21	4.69	2.11	8.20
B06	2.38	7.00	3.94	5.00	2.88	2.50	1.44	2.50	5.47	6.93	7.41	4.25	5.09	2.13	8.97
B08	2.62	7.50	5.12	6.38	3.38	3.19	1.69	2.94	7.23	7.99	8.58	5.43	5.63	2.72	10.98
B09	3.00	9.00	5.12	7.00	4.00	3.50	2.00	3.25	7.63	8.88	9.70	5.43	6.75	2.72	12.13
B10	3.25	9.05	5.67	7.50	4.00	3.75	2.00	3.50	7.64	9.38	10.28	5.98	7.06	2.99	12.16
B11	3.54	9.50	5.12	7.50	4.00	3.75	2.00	3.39	8.39	9.84	11.34	6.65	7.75	3.33	13.10

Case Size	C.D.	T Dia.	OUTPUT SHAFT				W-KEY		INPUT SHAFT		Z-KEY		WT (LBS)
			U Dia.	U1 Dia.	V	V1	SQ.	LG	X Dia.	Y	SQ.	LG	
B02	1.33	M8 x 0.47	0.750	1.000	1.88	0.12	3/16	1.00	0.625	1.31	3/16	1.00	9
B03	1.54	M8 x 0.47	0.750	1.000	1.99	0.08	3/16	1.13	0.750	1.48	3/16	1.13	14
B04	1.75	M8 x 0.47	1.000	1.438	1.97	0.08	1/4	1.25	0.750	1.48	3/16	1.13	16
B05	1.97	M10 x 0.59	1.125	1.438	2.39	0.08	1/4	1.50	0.750	1.48	3/16	1.13	18
B06	2.38	M10 x 0.59	1.125	1.438	2.77	0.08	1/4	1.88	0.750	1.48	3/16	1.13	23
B08	2.62	M10 x 0.59	1.500	1.938	2.68	0.08	3/8	1.94	1.188	2.69	1/4	2.25	40
B09	3.00	M12 x 0.71	1.500	2.188	3.80	0.08	3/8	2.00	1.188	2.69	1/4	2.25	47
B10	3.25	M12 x 0.71	1.500	2.188	3.83	0.08	3/8	2.25	1.188	2.69	1/4	2.25	50
B11	3.54	M16 x 0.87	1.875	2.938	4.15	0.10	1/2	2.63	1.188	2.95	1/4	2.25	70

NOTE: Refer to pages 13 - 14 for shaft and bore tolerances.

# Series B

# Reducer Dimensions - Single Reduction Units

## Unit With Horizontal Base (Over Driven)

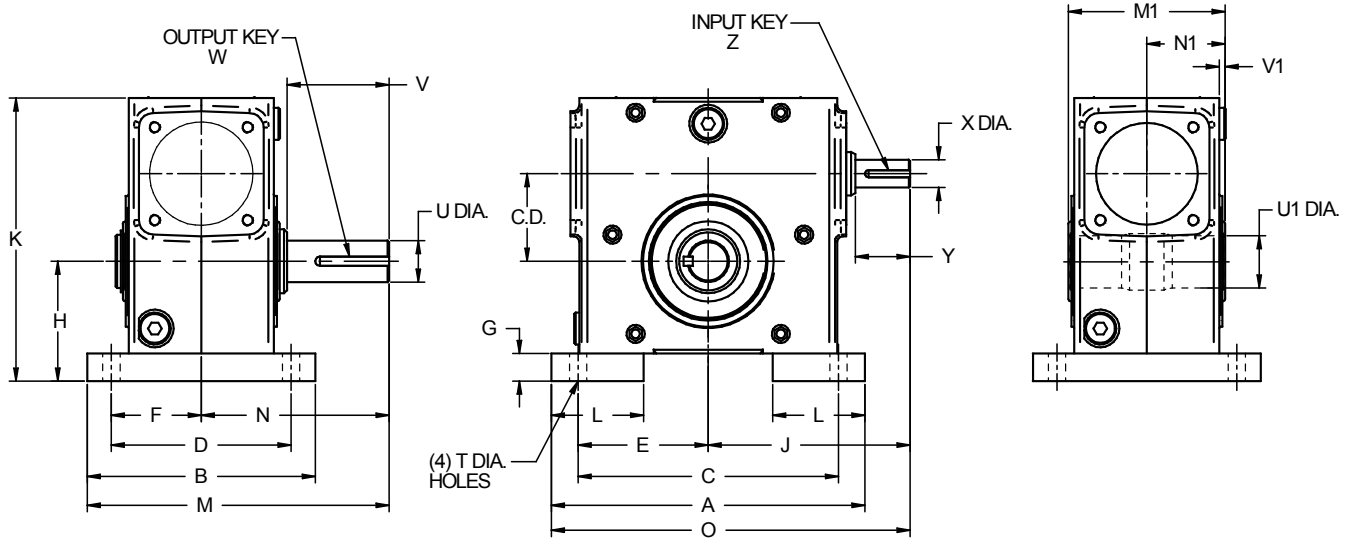

Case Size	C.D.	A	B	C	D	E	F	G	H	J	K	L	M	M1	N	N1
B02	1.33	5.38	4.19	4.380	3.310	2.190	1.655	0.53	2.25	4.22	5.19	1.50	6.10	3.85	4.00	1.93
B03	1.54	6.44	5.44	5.250	4.312	2.625	2.156	0.59	2.50	4.87	5.94	1.50	7.03	4.25	4.31	2.12
B04	1.75	7.00	5.69	5.750	4.500	2.875	2.250	0.69	2.75	5.13	6.44	2.00	7.16	4.29	4.31	2.15
B05	1.97	7.75	5.94	6.380	4.690	3.190	2.345	0.72	3.00	5.20	7.10	2.00	7.66	4.21	4.69	2.11
B06	2.38	8.50	6.19	7.063	4.875	3.532	2.438	0.75	3.25	5.47	7.68	2.50	8.19	4.25	5.09	2.13
B08	2.62	9.63	6.66	8.000	5.250	4.000	4.625	0.75	3.69	7.23	8.74	2.50	8.96	5.43	5.63	2.72
B09	3.00	10.00	7.50	8.440	5.880	4.220	2.940	0.75	4.00	7.63	9.63	2.00	10.50	5.43	6.75	2.72
B10	3.25	11.19	7.66	9.500	6.125	4.750	3.063	0.88	4.38	7.64	10.25	2.50	10.89	5.98	7.06	2.99
B11	3.54	11.08	7.71	9.500	6.120	4.750	3.060	1.61	5.00	8.39	11.45	2.50	11.61	6.65	7.75	3.33

Case Size	C.D.	O	T Dia.	OUTPUT SHAFT				W-KEY		INPUT SHAFT		Z-KEY		WT (LBS)
				U Dia.	U1 Dia.	V	V1	SQ.	LG	X Dia.	Y	SQ.	LG	
B02	1.33	6.91	11/32	0.750	1.000	1.88	0.12	3/16	1.00	0.625	1.31	3/16	1.00	10
B03	1.54	8.15	13/32	0.750	1.000	1.99	0.08	3/16	1.13	0.750	1.48	3/16	1.13	15
B04	1.75	8.70	13/32	1.000	1.438	1.97	0.08	1/4	1.25	0.750	1.48	3/16	1.13	18
B05	1.97	9.07	15/32	1.125	1.438	2.39	0.08	1/4	1.50	0.750	1.48	3/16	1.13	20
B06	2.38	9.72	15/32	1.125	1.438	2.77	0.08	1/4	1.88	0.750	1.48	3/16	1.13	25
B08	2.62	12.05	17/32	1.500	1.938	2.68	0.08	3/8	1.94	1.188	2.69	1/4	2.25	43
B09	3.00	12.63	17/32	1.500	2.188	3.80	0.08	3/8	2.00	1.188	2.69	1/4	2.25	50
B10	3.25	13.22	17/32	1.500	2.188	3.83	0.08	3/8	2.25	1.188	2.69	1/4	2.25	54
B11	3.54	13.89	9/16	1.875	2.938	4.15	0.10	1/2	2.63	1.188	2.95	1/4	2.62	75

NOTE: Refer to pages 13 - 14 for shaft and bore tolerances.

# Series B

# Reducer Dimensions - Single Reduction Units

## Unit With Horizontal Base (Under Driven)

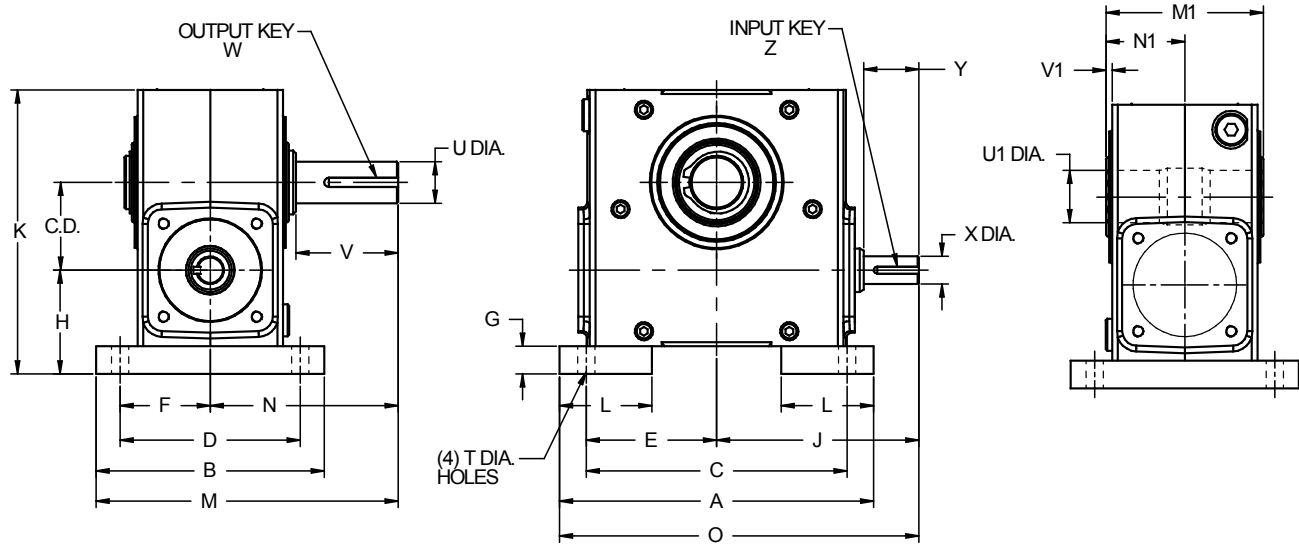

Case Size	C.D.	A	B	C	D	E	F	G	H	J	K	L	M	M1	N	N1
B02	1.33	5.38	4.19	4.380	3.310	2.190	1.655	0.53	2.14	4.22	5.19	1.50	6.10	3.85	4.00	1.93
B03	1.54	6.44	5.44	5.250	4.312	2.625	2.156	0.59	2.49	4.87	5.94	1.50	7.03	4.25	4.31	2.12
B04	1.75	7.00	5.69	5.750	4.500	2.875	2.250	0.69	2.63	5.13	6.44	2.00	7.16	4.29	4.31	2.15
B05	1.97	7.75	5.94	6.380	4.690	3.190	2.345	0.72	2.85	5.20	7.10	2.00	7.66	4.21	4.69	2.11
B06	2.38	8.50	6.19	7.063	4.875	3.532	2.438	0.75	2.80	5.47	7.68	2.50	8.19	4.25	5.09	2.13
B08	2.62	9.63	6.66	8.000	5.250	4.000	4.625	0.75	3.18	7.23	8.74	2.50	8.96	5.43	5.63	2.72
B09	3.00	10.00	7.50	8.440	5.880	4.220	2.940	0.75	3.38	7.63	9.63	2.00	10.50	5.43	6.75	2.72
B10	3.25	11.19	7.66	9.500	6.125	4.750	3.063	0.88	3.50	7.64	10.25	2.50	10.89	5.98	7.06	2.99
B11	3.54	11.08	7.71	9.500	6.120	4.750	3.060	1.61	4.53	8.39	11.45	2.50	11.61	6.65	7.75	3.33

Case Size	C.D.	O	T Dia.	OUTPUT SHAFT				W-KEY		INPUT SHAFT		Z-KEY		WT (LBS)
				U Dia.	U1 Dia.	V	V1	SQ.	LG	X Dia.	Y	SQ.	LG	
B02	1.33	6.91	11/32	0.750	1.000	1.88	0.12	3/16	1.00	0.625	1.31	3/16	1.00	10
B03	1.54	8.15	13/32	0.750	1.000	1.99	0.08	3/16	1.13	0.750	1.48	3/16	1.13	15
B04	1.75	8.70	13/32	1.000	1.438	1.97	0.08	1/4	1.25	0.750	1.48	3/16	1.13	18
B05	1.97	9.07	15/32	1.125	1.438	2.39	0.08	1/4	1.50	0.750	1.48	3/16	1.13	20
B06	2.38	9.72	15/32	1.125	1.438	2.77	0.08	1/4	1.88	0.750	1.48	3/16	1.13	25
B08	2.62	12.05	17/32	1.500	1.938	2.68	0.08	3/8	1.94	1.188	2.69	1/4	2.25	43
B09	3.00	12.63	17/32	1.500	2.188	3.80	0.08	3/8	2.00	1.188	2.69	1/4	2.25	50
B10	3.25	13.22	17/32	1.500	2.188	3.83	0.08	3/8	2.25	1.188	2.69	1/4	2.25	54
B11	3.54	13.89	9/16	1.875	2.938	4.15	0.10	1/2	2.63	1.188	2.95	1/4	2.25	75

NOTE: Refer to pages 13 - 14 for shaft and bore tolerances.

# Series B

# Reducer Dimensions - Single Reduction Units

## Unit With Vertical Base (High & Low)

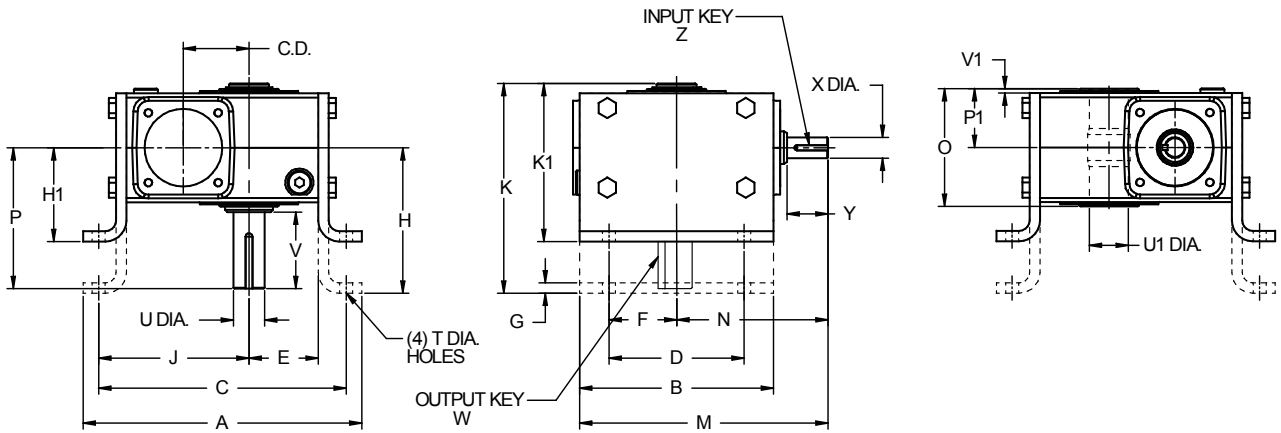

Case Size	C.D.	A	B	C	D	E	F	G	H	H1	J	K	K1	M	N	O
B02	1.33	7.09	4.33	6.16	3.25	1.72	1.63	0.25	3.56	2.31	3.69	5.66	4.41	6.38	4.22	3.85
B03	1.54	8.04	5.23	6.98	4.00	1.91	2.00	0.25	4.38	3.00	4.26	6.68	5.30	7.55	4.87	4.25
B04	1.75	8.44	5.98	7.38	4.00	2.06	2.00	0.31	4.38	3.00	4.51	6.72	5.34	8.19	5.13	4.29
B05	1.97	9.50	6.00	8.38	4.88	2.28	2.44	0.38	4.88	3.13	5.10	7.19	5.44	8.20	5.20	4.21
B06	2.38	10.06	7.00	8.95	4.88	2.50	2.44	0.38	5.25	3.38	5.44	7.57	5.70	8.97	5.47	4.25
B08	2.62	11.69	7.50	10.17	5.75	2.94	2.88	0.38	5.59	3.63	6.14	8.54	6.58	10.98	7.23	5.43
B09	3.00	13.25	9.00	11.14	6.00	3.25	3.00	0.38	5.88	3.94	6.76	8.83	6.89	12.13	7.63	5.43
B10	3.25	13.37	9.05	11.87	6.13	3.50	3.07	0.50	6.25	4.69	7.12	9.47	7.91	12.16	7.64	5.98
B11	3.54	16.84	9.50	14.88	7.88	3.39	3.94	0.50	7.50	5.00	8.99	11.09	8.59	13.10	8.39	6.65

Case Size	C.D.	P	P1	T Dia.	OUTPUT SHAFT				W-KEY		INPUT SHAFT		Z-KEY		WT (LBS)
					U Dia.	U1 Dia.	V	V1	SQ.	LG	X Dia.	Y	SQ.	LG	
B02	1.33	4.00	1.93	11/32	0.750	1.000	1.88	0.12	3/16	1.00	0.625	1.31	3/16	1.00	10
B03	1.54	4.31	2.12	13/32	0.750	1.000	1.99	0.08	3/16	1.13	0.750	1.48	3/16	1.13	15
B04	1.75	4.31	2.15	13/32	1.000	1.438	1.97	0.08	1/4	1.25	0.750	1.48	3/16	1.13	18
B05	1.97	4.69	2.11	15/32	1.125	1.438	2.39	0.08	1/4	1.50	0.750	1.48	3/16	1.13	20
B06	2.38	5.09	2.13	15/32	1.125	1.438	2.77	0.08	1/4	1.88	0.750	1.48	3/16	1.13	25
B08	2.62	5.63	2.72	17/32	1.500	1.938	2.68	0.08	3/8	1.94	1.188	2.69	1/4	2.25	44
B09	3.00	6.75	2.72	17/32	1.500	2.188	3.80	0.08	3/8	2.00	1.188	2.69	1/4	2.25	51
B10	3.25	7.06	2.99	17/32	1.500	2.188	3.83	0.08	3/8	2.25	1.188	2.69	1/4	2.25	55
B11	3.54	7.75	3.33	19/32	1.875	2.938	4.15	0.10	1/2	2.63	1.188	2.95	1/4	2.62	76

NOTE: Refer to pages 13 - 14 for shaft and bore tolerances.

# Series B

# Reducer Dimensions - Single Reduction Units

## Unit With End Mounted Base

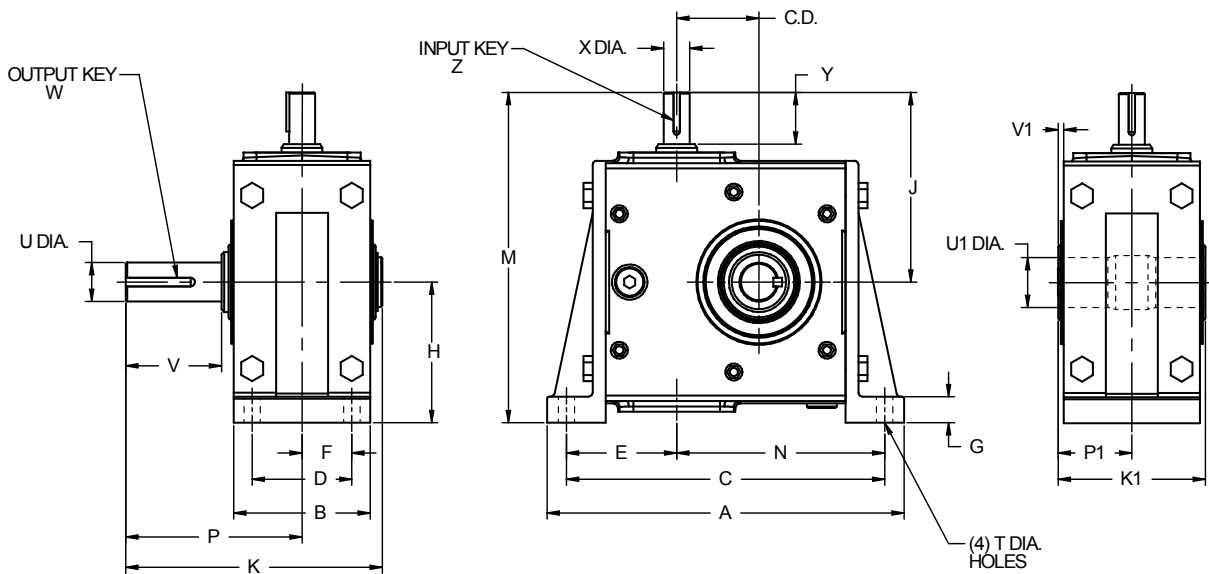

Case Size	C.D.	A	B	C	D	E	F	G	H	J	K	K1	M	N
B02	1.33	7.28	2.76	6.41	2.00	2.48	1.00	0.53	2.94	4.22	6.10	3.85	7.16	3.93
B03	1.54	8.26	3.94	7.26	2.50	2.86	1.25	0.69	3.50	4.87	6.61	4.25	8.43	4.41
B04	1.75	8.62	3.94	7.63	2.50	2.88	1.25	0.69	3.50	5.13	6.65	4.29	8.70	4.75
B05	1.97	9.75	3.94	8.63	2.63	3.26	1.32	0.72	3.94	5.20	7.00	4.21	9.14	5.37
B06	2.38	10.31	3.94	9.19	2.88	3.18	1.44	0.75	4.06	5.47	7.41	4.25	9.53	6.00
B08	2.62	11.88	5.12	10.38	3.13	3.62	1.57	0.88	4.63	7.23	8.58	5.43	11.86	6.76
B09	3.00	13.45	5.12	11.38	3.88	3.88	1.94	0.88	5.62	7.63	9.70	5.43	13.25	7.50
B10	3.25	13.84	5.67	11.87	3.88	3.88	1.94	0.88	5.63	7.64	10.28	5.98	13.26	8.00
B11	3.54	16.85	6.12	14.88	5.00	5.43	2.50	0.94	6.50	8.39	11.34	6.65	14.85	9.45

Case Size	C.D.	OUTPUT SHAFT				W-KEY		INPUT SHAFT		Z-KEY		WT (LBS)			
		P	P1	T Dia.	U Dia.	U1 Dia.	V	V1	SQ.	LG	X Dia.		Y	SQ.	LG
B02	1.33	4.00	1.93	11/32	0.750	1.000	1.88	0.12	3/16	1.00	0.625	1.31	3/16	1.00	10
B03	1.54	4.31	2.12	13/32	0.750	1.000	1.99	0.08	3/16	1.13	0.750	1.48	3/16	1.13	15
B04	1.75	4.31	2.15	13/32	1.000	1.438	1.97	0.08	1/4	1.25	0.750	1.48	3/16	1.13	18
B05	1.97	4.69	2.11	15/32	1.125	1.438	2.39	0.08	1/4	1.50	0.750	1.48	3/16	1.13	21
B06	2.38	5.09	2.13	15/32	1.125	1.438	2.77	0.08	1/4	1.88	0.750	1.48	3/16	1.13	26
B08	2.62	5.63	2.72	17/32	1.500	1.938	2.68	0.08	3/8	1.94	1.188	2.69	1/4	2.25	44
B09	3.00	6.75	2.72	17/32	1.500	2.188	3.80	0.08	3/8	2.00	1.188	2.69	1/4	2.25	51
B10	3.25	7.06	2.99	17/32	1.500	2.188	3.83	0.08	3/8	2.25	1.188	2.69	1/4	2.25	55
B11	3.54	7.75	3.33	19/32	1.875	2.938	4.15	0.10	1/2	2.63	1.188	2.95	1/4	2.62	76

NOTE: Refer to pages 13 - 14 for shaft and bore tolerances.

# Series B

## Reducer Dimensions - Double Reduction Units

### Standard Unit (No Base)

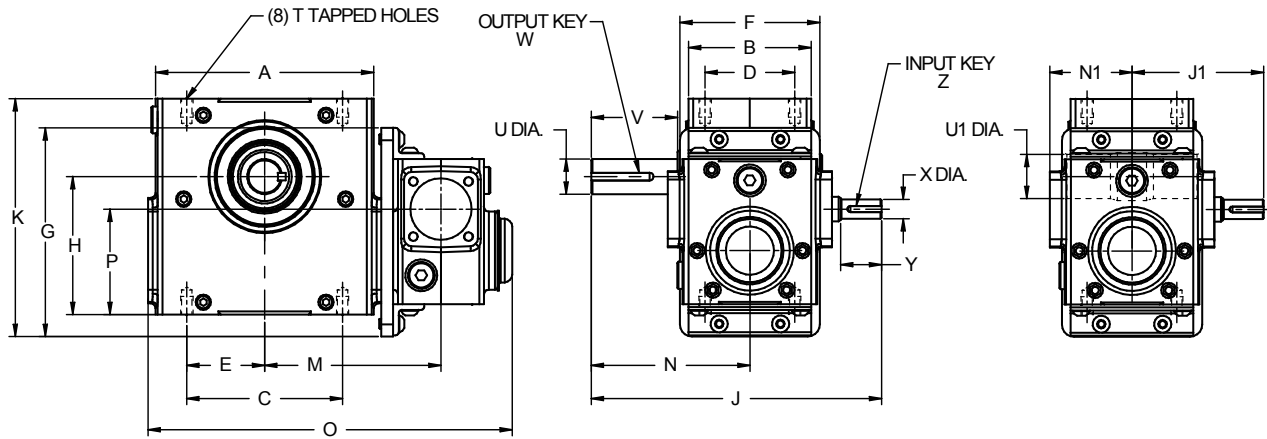

Size	A	B	C	D	E	F	G	H	J	J1	K	M	N	N1
B0520	6.00	3.94	5.00	2.88	2.50	4.50	6.69	4.10	8.91	4.22	7.00	5.28	4.69	2.64
B0620	7.00	3.94	5.00	2.88	2.50	4.50	6.69	4.43	9.31	4.22	7.63	5.71	5.09	2.64
B0820	7.50	5.12	6.38	3.38	3.19	5.98	8.27	5.05	10.76	5.13	8.87	6.79	5.63	3.15
B0920	9.00	5.12	7.00	4.00	3.50	5.98	8.27	5.63	11.88	5.13	9.56	7.19	6.75	3.15
B1020	9.05	5.67	7.50	4.00	3.75	5.98	8.82	5.88	12.26	5.20	10.25	7.22	7.06	3.31
B1120	9.50	5.12	7.50	4.00	3.75	5.98	8.82	6.46	12.95	5.20	10.43	7.66	7.75	3.31

Case Size	O	P	T Dia.	OUTPUT SHAFT			W-KEY		INPUT SHAFT		Z-KEY		WT (LBS)
				U Dia.	U1 Dia.	V	SQ.	LG	X Dia.	Y	SQ.	LG	
B0520	10.89	3.46	M10 x 0.59	1.125	1.438	2.39	1/4	1.50	0.625	1.31	3/16	1.00	32
B0620	11.76	3.39	M10 x 0.59	1.125	1.438	2.77	1/4	1.88	0.625	1.31	3/16	1.00	37
B0820	13.57	4.18	M10 x 0.59	1.500	1.938	2.68	3/8	1.94	0.750	1.48	3/16	1.13	65
B0920	14.35	4.38	M12 x 0.71	1.500	2.188	3.80	3/8	2.00	0.750	1.48	3/16	1.13	72
B1020	14.44	4.59	M12 x 0.71	1.500	2.188	3.83	3/8	2.25	0.750	1.48	3/16	1.13	78
B1120	15.31	4.88	M16 x 0.87	1.875	2.938	4.15	1/2	2.63	0.750	1.48	3/16	1.13	98

NOTE: Refer to pages 13 - 14 for shaft and bore tolerances.

# Series B

## Reducer Dimensions - Double Reduction Units

### Standard Unit (No Base)

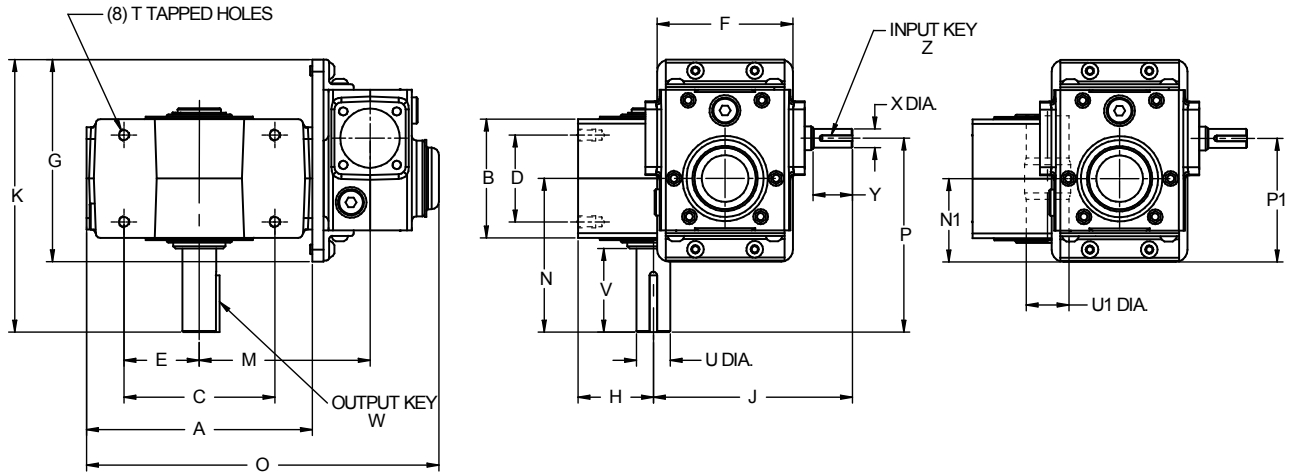

Size	A	B	C	D	E	F	G	H	J	K	M	N	N1	O
B0520	1.00	3.94	5.00	2.88	2.50	4.50	6.69	2.28	6.19	8.63	5.28	4.69	2.76	10.89
B0620	1.00	3.94	5.00	2.88	2.50	4.50	6.69	2.50	6.60	9.03	5.71	5.09	2.76	11.76
B0820	1.00	5.12	6.38	3.38	3.19	5.98	8.27	2.94	7.75	10.69	6.79	5.63	3.31	13.57
B0920	1.00	5.12	7.00	4.00	3.50	5.98	8.27	3.25	8.13	11.71	7.19	6.75	3.31	14.35
B1020	1.00	5.67	7.50	4.00	3.75	5.98	8.82	3.50	8.45	12.37	7.22	7.06	3.50	14.44
B1120	1.00	5.12	7.50	4.00	3.75	5.98	8.82	3.39	8.74	13.06	7.66	7.75	3.50	15.31

Size	P	P1	T Dia.	OUTPUT SHAFT			W-KEY		INPUT SHAFT		Z-KEY		WT (LBS)
				U Dia.	U1 Dia.	V	SQ.	LG	X Dia.	Y	SQ.	LG	
B0520	6.02	4.09	M10 x 0.59	1.125	1.438	2.39	1/4	1.50	0.625	1.31	3/16	1.00	32
B0620	6.42	4.09	M10 x 0.59	1.125	1.438	2.77	1/4	1.88	0.625	1.31	3/16	1.00	37
B0820	7.38	5.06	M10 x 0.59	1.500	1.938	2.68	3/8	1.94	0.750	1.48	3/16	1.13	65
B0920	8.50	5.06	M12 x 0.71	1.500	2.188	3.80	3/8	2.00	0.750	1.48	3/16	1.13	72
B1020	9.03	5.47	M12 x 0.71	1.500	2.188	3.83	3/8	2.25	0.750	1.48	3/16	1.13	78
B1120	9.72	5.47	M16 x 0.87	1.875	2.938	4.15	1/2	2.63	0.750	1.48	3/16	1.13	98

NOTE: Refer to pages 13 - 14 for shaft and bore tolerances.

# Series B

# Reducer Dimensions - Double Reduction Units

## Unit With Output Bracket

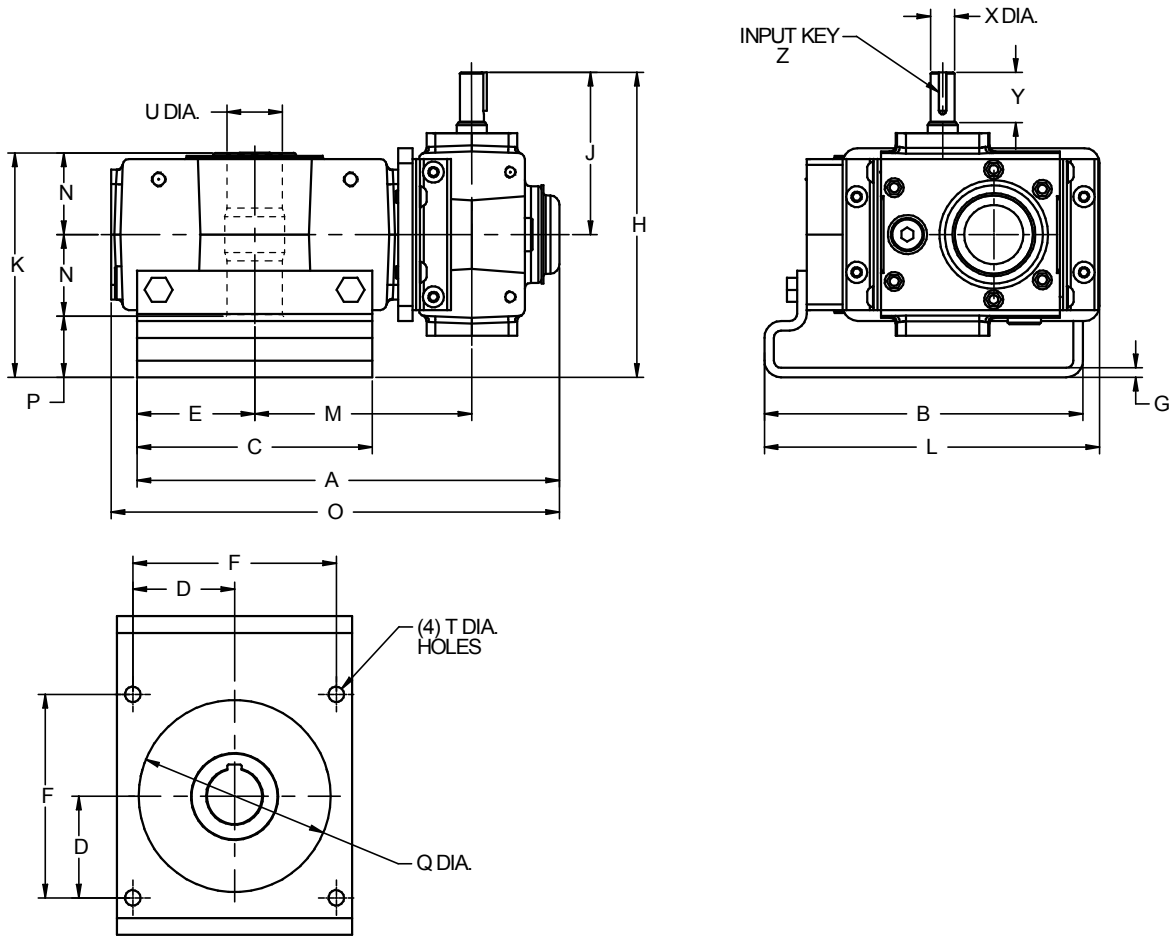

Size	A	B	C	D	E	F	G	H	J	K	L	M	N
B0520	10.46	7.47	5.75	2.30	2.87	4.60	0.19	7.97	4.22	5.86	7.90	5.28	2.11
B0620	11.09	8.30	6.13	2.65	3.07	5.30	0.25	7.94	4.22	5.85	8.75	5.71	2.13
B0820	12.95	9.25	7.18	2.83	3.59	5.66	0.25	9.19	5.13	6.78	9.87	6.79	2.72
B0920	14.00	10.02	8.50	3.18	4.25	6.36	0.25	9.63	5.13	7.22	10.44	7.19	2.72
B1020	14.01	10.91	8.50	3.54	4.25	7.07	0.25	10.45	5.20	8.24	11.53	7.22	2.99
B1120	14.94	12.35	9.50	3.54	4.75	7.07	0.25	10.45	5.20	8.58	12.67	7.66	3.33

Case Size	O	P	Q Dia	T Dia	U Dia	INPUT SHAFT		Z-KEY		WT (LBS)
						X Dia.	Y	SQ.	LG	
B0520	10.89	1.64	4.50	13/32	1.438	0.625	1.31	3/16	1.00	32
B0620	11.76	1.59	5.00	13/32	1.438	0.625	1.31	3/16	1.00	37
B0820	13.57	1.34	6.00	13/32	1.938	0.750	1.48	3/16	1.13	65
B0920	14.35	1.78	7.00	13/32	2.188	0.750	1.48	3/16	1.13	72
B1020	14.44	2.26	7.00	9/16	2.188	0.750	1.48	3/16	1.13	78
B1120	15.31	1.92	8.56	9/16	2.938	0.750	1.48	3/16	1.13	98

NOTE: Refer to pages 13 - 14 for shaft and bore tolerances.

# Series B

# Reducer Dimensions - Double Reduction Units

## Unit With Output Bracket

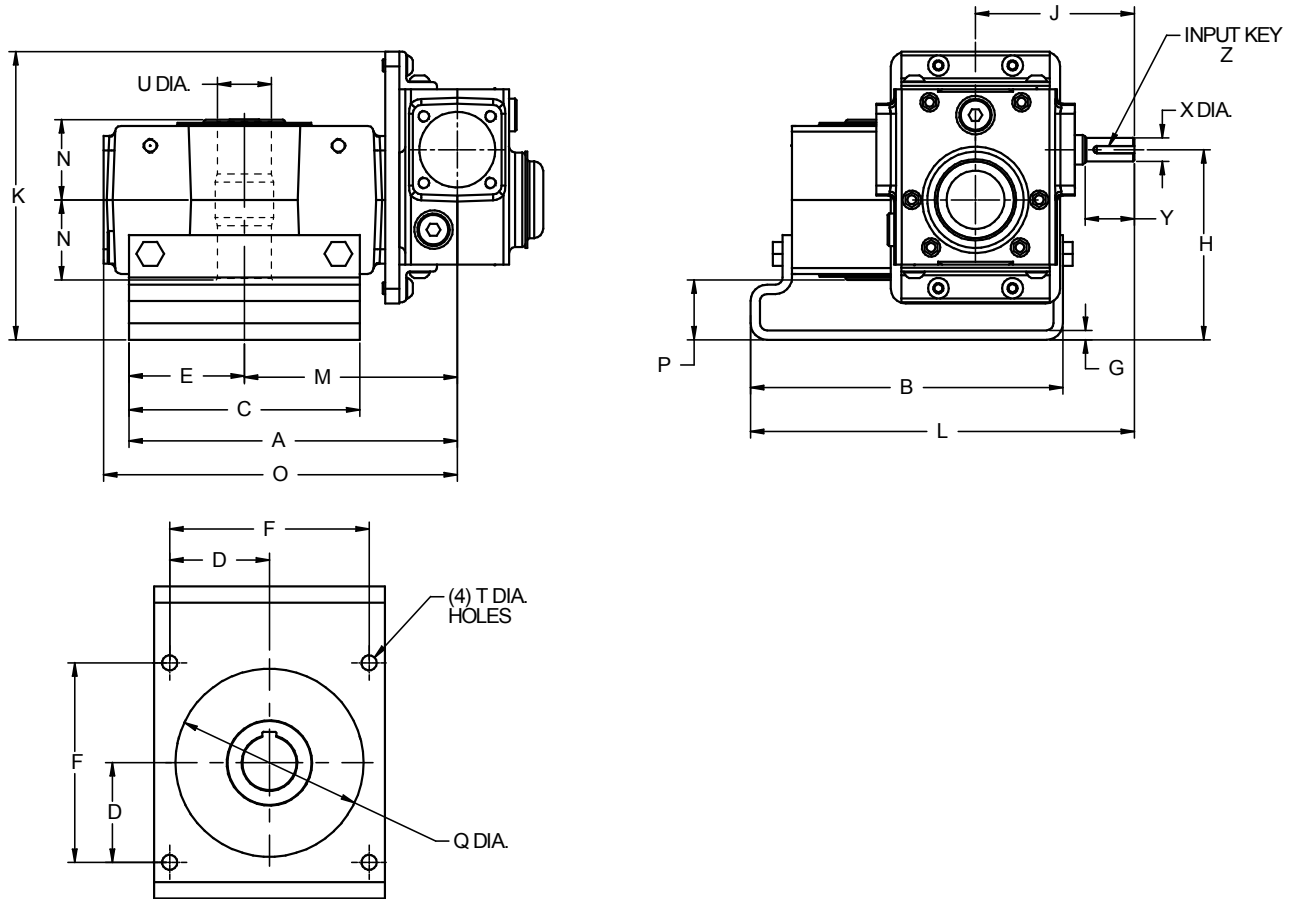

Size	A	B	C	D	E	F	G	H	J	K	L	M	N
B0520	8.16	7.47	5.75	2.30	2.88	4.60	0.19	5.08	4.22	7.69	9.36	5.28	2.11
B0620	8.59	8.30	5.75	2.65	2.88	5.30	0.25	5.05	4.22	7.66	10.21	5.71	2.13
B0820	10.38	9.25	7.18	2.83	3.59	5.66	0.25	5.81	5.13	9.02	11.69	6.79	2.72
B0920	11.44	10.02	8.50	3.18	4.25	6.36	0.25	6.25	5.13	9.46	12.26	7.19	2.72
B1020	11.48	10.91	8.50	3.54	4.25	7.07	0.25	7.22	5.20	10.56	13.23	7.22	2.99
B1120	12.41	12.35	9.50	3.54	4.75	7.07	0.25	7.22	5.20	10.56	14.37	7.66	3.33

Case Size						INPUT SHAFT		Z-KEY		WT (LBS)
	O	P	Q Dia	T Dia	U Dia	X Dia.	Y	SQ.	LG	
B0520	8.58	1.64	4.50	13/32	1.438	0.625	1.31	3/16	1.00	32
B0620	9.45	1.59	5.00	13/32	1.438	0.625	1.31	3/16	1.00	37
B0820	11.00	1.34	6.00	13/32	1.938	0.750	1.48	3/16	1.13	65
B0920	11.79	1.78	7.00	13/32	2.188	0.750	1.48	3/16	1.13	72
B1020	11.91	2.26	7.00	9/16	2.188	0.750	1.48	3/16	1.13	78
B1120	12.78	1.92	8.56	9/16	2.938	0.750	1.48	3/16	1.13	98

NOTE: Refer to pages 13 - 14 for shaft and bore tolerances.

# Series B

## Reducer Dimensions - Double Reduction Units

### Standard Unit (No Base)

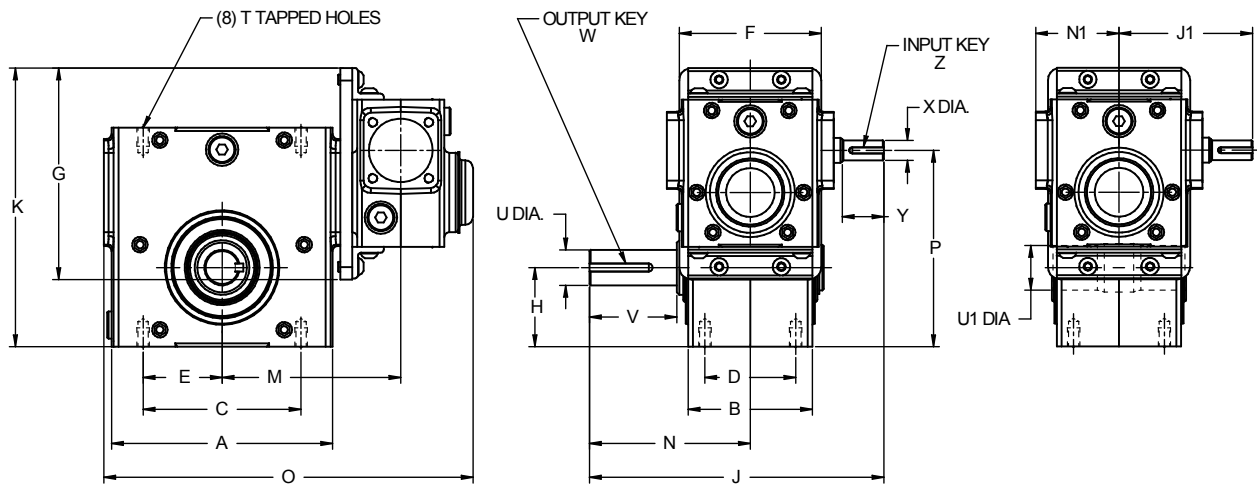

Size	A	B	C	D	E	F	G	H	J	J1	K	M	N	N1
B0520	6.00	3.94	5.00	2.88	2.50	4.50	6.69	2.28	8.91	4.22	7.00	5.28	4.69	2.64
B0620	7.00	3.94	5.00	2.88	2.50	4.50	6.69	2.50	9.31	4.22	7.63	5.71	5.09	2.64
B0820	7.50	5.12	6.38	3.38	3.19	5.98	8.27	2.94	10.76	5.13	8.87	6.79	5.63	3.15
B0920	9.00	5.12	7.00	4.00	3.50	5.98	8.27	3.25	11.88	5.13	9.56	7.19	6.75	3.15
B1020	9.05	5.67	7.50	4.00	3.75	5.98	8.82	3.50	12.26	5.20	10.25	7.22	7.06	3.31
B1120	9.50	5.12	7.50	4.00	3.75	5.98	8.82	3.39	12.95	5.20	10.43	7.66	7.75	3.31

Case Size	O	P	T Dia.	OUTPUT SHAFT			W-KEY		INPUT SHAFT		Z-KEY		WT (LBS)
				U Dia.	U1 Dia.	V	SQ.	LG	X Dia.	Y	SQ.	LG	
B0520	10.89	5.58	M10 x 0.59	1.125	1.438	2.39	1/4	1.50	0.625	1.31	3/16	1.00	32
B0620	11.76	6.21	M10 x 0.59	1.125	1.438	2.77	1/4	1.88	0.625	1.31	3/16	1.00	37
B0820	13.57	7.31	M10 x 0.59	1.500	1.938	2.68	3/8	1.94	0.750	1.48	3/16	1.13	65
B0920	14.35	8.00	M12 x 0.71	1.500	2.188	3.80	3/8	2.00	0.750	1.48	3/16	1.13	72
B1020	14.44	8.72	M12 x 0.71	1.500	2.188	3.83	3/8	2.25	0.750	1.48	3/16	1.13	78
B1120	15.31	8.90	M16 x 0.87	1.875	2.938	4.15	1/2	2.63	0.750	1.48	3/16	1.13	98

NOTE: Refer to pages 13 - 14 for shaft and bore tolerances.

# Series B

## Reducer Dimensions - Double Reduction Units

### Standard Unit (No Base)

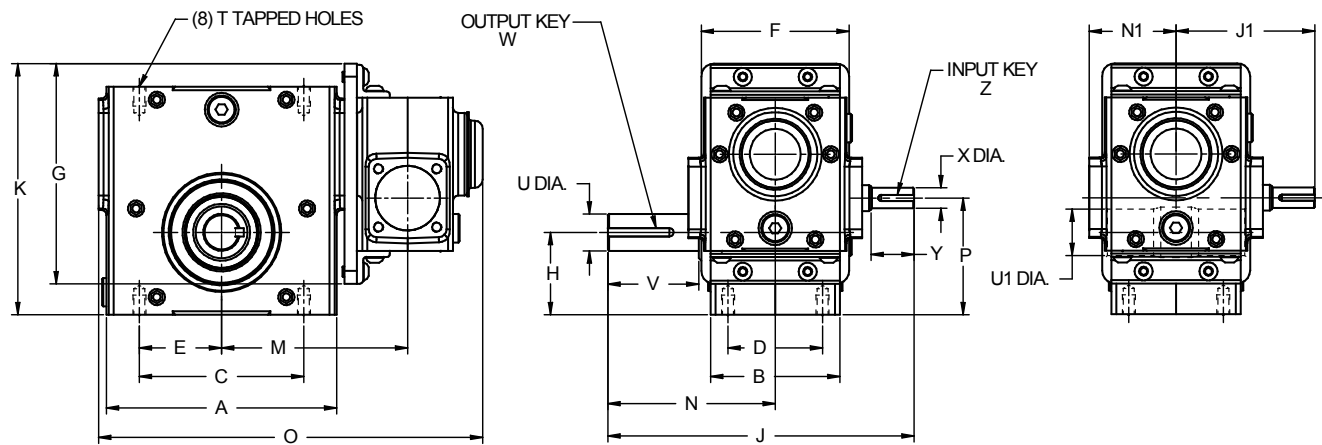

Size	A	B	C	D	E	F	G	H	J	J1	K	M	N	N1
B0520	6.00	3.94	5.00	2.88	2.50	4.50	6.69	2.28	8.91	4.22	8.19	5.28	4.69	2.64
B0620	7.00	3.94	5.00	2.88	2.50	4.50	6.69	2.50	9.31	4.22	8.82	5.71	5.09	2.64
B0820	7.50	5.12	6.38	3.38	3.19	5.98	8.27	2.94	10.76	5.13	10.52	6.79	5.63	3.15
B0920	9.00	5.12	7.00	4.00	3.50	5.98	8.27	3.25	11.88	5.13	11.21	7.19	6.75	3.15
B1020	9.05	5.67	7.50	4.00	3.75	5.98	8.82	3.50	12.26	5.20	12.06	7.22	7.06	3.31
B1120	9.50	5.12	7.50	4.00	3.75	5.98	8.82	3.39	12.95	5.20	12.24	7.66	7.75	3.31

Case Size	O	P	T Dia.	OUTPUT SHAFT			W-KEY		INPUT SHAFT		Z-KEY		WT (LBS)
				U Dia.	U1 Dia.	V	SQ.	LG	X Dia.	Y	SQ.	LG	
B0520	10.89	2.92	M10 x 0.59	1.125	1.438	2.39	1/4	1.50	0.625	1.31	3/16	1.00	32
B0620	11.76	3.54	M10 x 0.59	1.125	1.438	2.77	1/4	1.88	0.625	1.31	3/16	1.00	37
B0820	13.57	3.82	M10 x 0.59	1.500	1.938	2.68	3/8	1.94	0.750	1.48	3/16	1.13	65
B0920	14.35	4.50	M12 x 0.71	1.500	2.188	3.80	3/8	2.00	0.750	1.48	3/16	1.13	72
B1020	14.44	4.78	M12 x 0.71	1.500	2.188	3.83	3/8	2.25	0.750	1.48	3/16	1.13	78
B1120	15.31	4.96	M16 x 0.87	1.875	2.938	4.15	1/2	2.63	0.750	1.48	3/16	1.13	98

NOTE: Refer to pages 13 - 14 for shaft and bore tolerances.

## Customer Shaft Detail

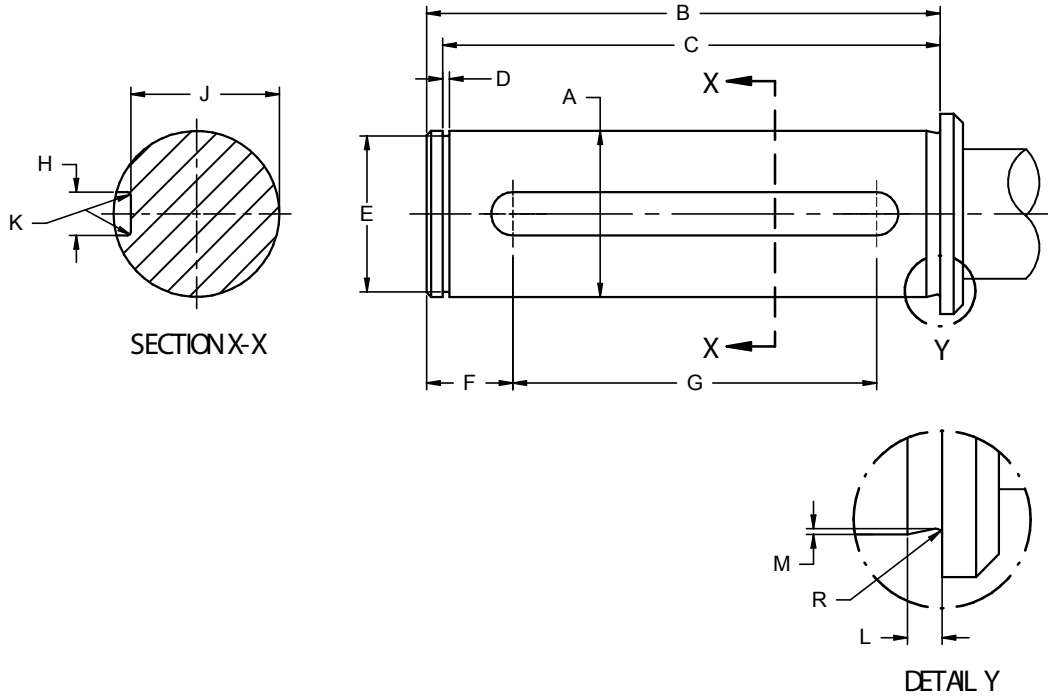

Case Size	A	B	C	D	E	F	G	H	J	K	L	M	R
B02	1.000	4.03	3.906	0.049	0.943	0.602	3.00	0.252	0.890	0.024R	0.12	0.02	0.04
	0.999		3.902	0.046	0.937			0.250					
B03	1.000	4.42	4.299	0.049	0.943	0.800	3.00	0.252	0.890	0.024R	0.12	0.02	0.04
	0.999		4.295	0.046	0.937			0.250					
B04	1.4375	4.49	4.350	0.060	1.354	0.768	3.15	0.377	1.288	0.031R	0.12	0.02	0.04
	1.4365		4.346	0.056	1.346			0.375					
B05	1.4375	4.42	4.271	0.060	1.354	0.736	3.15	0.377	1.288	0.031R	0.12	0.02	0.04
	1.4365		4.267	0.056	1.346			0.375					
B06	1.4375	4.45	4.311	0.060	1.354	0.748	3.15	0.377	1.288	0.031R	0.12	0.02	0.04
	1.4365		4.307	0.056	1.346			0.375					
B08	1.9375	5.67	5.505	0.072	1.862	0.882	4.13	0.502	1.717	0.047R	0.12	0.02	0.04
	1.9365		5.501	0.068	1.852			0.500					
B09	2.1875	5.67	5.521	0.091	2.038	0.882	4.13	0.502	1.971	0.047R	0.12	0.02	0.04
	2.1865		5.517	0.086	2.026			0.500					
B10	2.1875	6.22	6.072	0.091	2.038	0.975	4.50	0.502	1.971	0.047R	0.12	0.02	0.04
	2.1865		6.068	0.086	2.026			0.500					
B11	2.9375	6.92	6.756	0.108	2.785	0.836	5.51	0.752	2.639	0.062R	0.12	0.02	0.04
	2.9365		6.752	0.103	2.773			0.750					

### Shaft Mount Units

### Alternative Shaft Mounting Methods

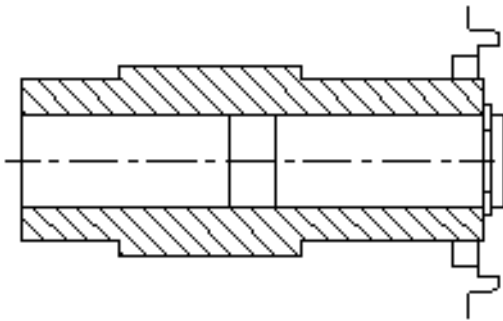

Shaft Mount Units Retained With A  
Snap Ring

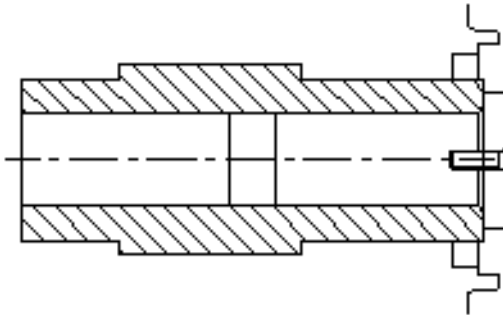

Shaft Mount Units Retained With A  
Bolt And Plate

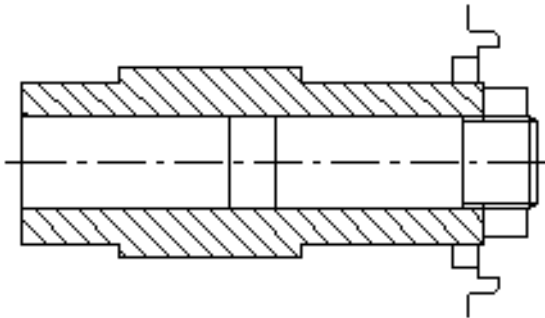

Shaft Mount Units Retained With A  
Locknut

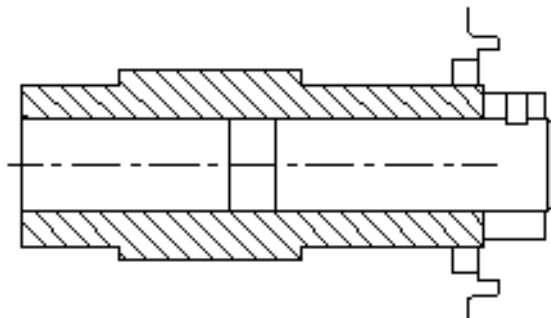

Shaft Mount Units Retained With A  
Collar And Set Screw

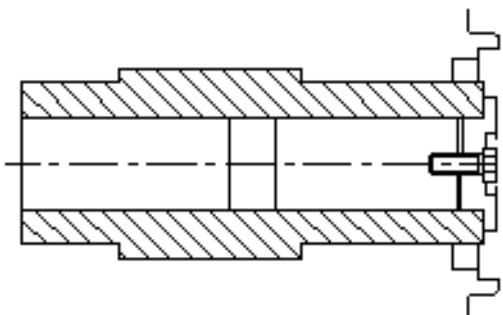

Shaft Mount Units Retained With A  
Recessed Plate And Bolt

## Torque Arm Details

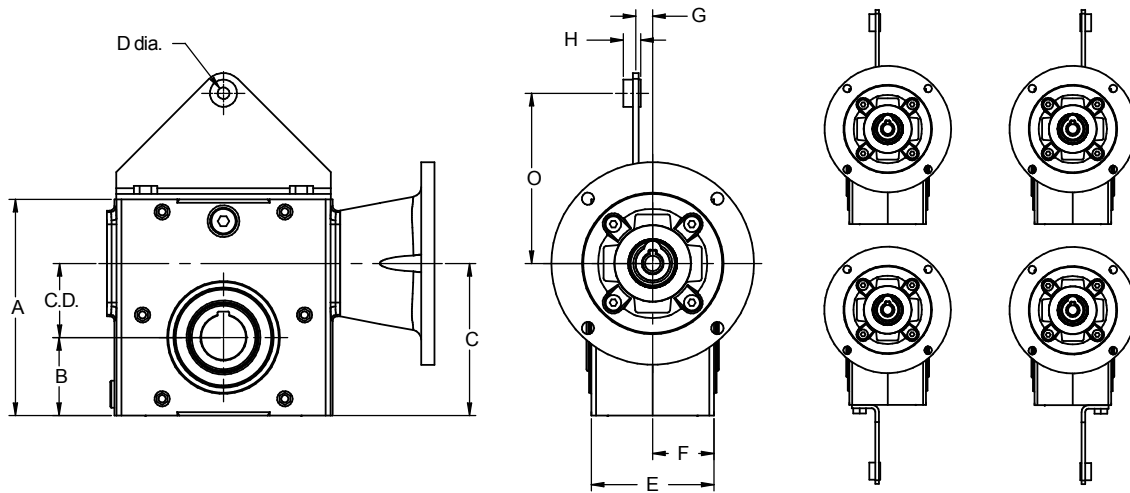

Case Size	C.D.	A	B	C	D dia.	E	F	G	H	O
B02	1.33	4.66	1.72	3.05	0.39	2.76	1.38	0.55	0.55	3.82
B03	1.54	5.35	1.91	3.45	0.39	3.94	1.97	0.92	0.55	3.93
B04	1.75	5.75	2.06	3.81	0.39	3.94	1.97	0.82	0.55	3.82
B05	1.97	6.38	2.28	4.25	0.39	3.94	1.97	0.79	0.55	5.76
B06	2.38	6.93	2.50	4.88	0.39	3.94	1.97	0.69	0.55	5.46
B08	2.62	7.99	2.94	5.56	0.79	5.12	2.56	0.92	0.98	7.36
B09	3.00	8.88	3.25	6.25	0.79	5.12	2.56	1.19	0.98	7.25
B10	3.25	9.38	3.50	6.75	0.79	5.67	2.84	1.19	0.98	7.00
B11	3.54	9.84	3.39	6.93	0.98	5.12	2.56	1.07	0.98	9.37



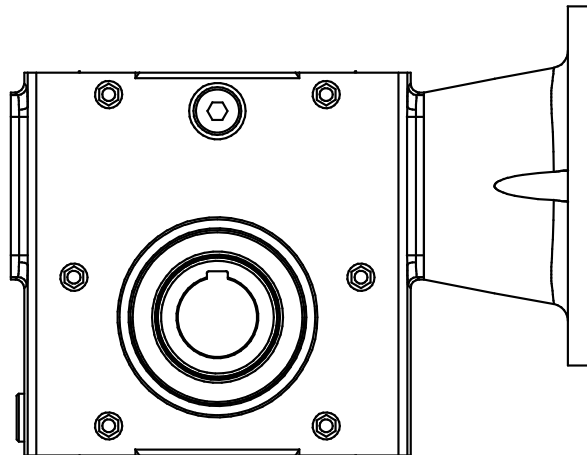
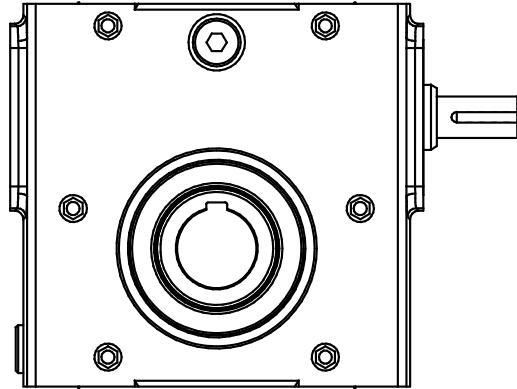

KIT SELECTION

**SERIES B**

	B02	B03	B04
RATIO	INCH BORE	INCH BORE	INCH BORE
5:1	B02-05-A	B03-05-A	B04-05-A
7.5:1	B02-07-A	B03-07-A	B04-07-A
10:1	B02-10-A	B03-10-A	B04-10-A
15:1	B02-15-A	B03-15-A	B04-15-A
20:1	B02-20-A	B03-20-A	B04-20-A
25:1	B02-25-A	B03-25-A	B04-25-A
30:1	B02-30-A	B03-30-A	B04-30-A
40:1	B02-40-A	B03-40-A	B04-40-A
50:1	B02-50-A	B03-50-A	B04-50-A
60:1	B02-60-A	B03-60-A	B04-60-A

	B05	B06	B08
RATIO	INCH BORE	INCH BORE	INCH BORE
5:1	B05-05-A	B06-05-A	B08-05-A
7.5:1	B05-07-A	B06-07-A	B08-07-A
10:1	B05-10-A	B06-10-A	B08-10-A
15:1	B05-15-A	B06-15-A	B08-15-A
20:1	B05-20-A	B06-20-A	B08-20-A
25:1	B05-25-A	B06-25-A	B08-25-A
30:1	B05-30-A	B06-30-A	B08-30-A
40:1	B05-40-A	B06-40-A	B08-40-A
50:1	B05-50-A	B06-50-A	B08-50-A
60:1	B05-60-A	B06-60-A	B08-60-A

	B09	B10	B11
RATIO	INCH BORE	INCH BORE	INCH BORE
5:1	B09-05-A	B10-05-A	B11-05-A
7.5:1	B09-07-A	B10-07-A	B11-07-A
10:1	B09-10-A	B10-10-A	B11-10-A
15:1	B09-15-A	B10-15-A	B11-15-A
20:1	B09-20-A	B10-20-A	B11-20-A
25:1	B09-25-A	B10-25-A	B11-25-A
30:1	B09-30-A	B10-30-A	B11-30-A
40:1	B09-40-A	B10-40-A	B11-40-A
50:1	B09-50-A	B10-50-A	B11-50-A
60:1	B09-60-A	B10-60-A	B11-60-A

# Series B

# NEMA & IEC Motor Adaptor Kits

## Nema C Face Motor Adaptor Kits

### Single Stage Units

Motor Frame	Unit Size								
	B0210	B0310	B0410	B0510	B0610	B0810	B0910	B1010	B1110
56C	U	T	T	T	T	Q	Q	Q	Q
143TC/145TC	W	V	V	V	V	R	R	R	R
182TC/184TC		X	X	X	X	T	T	T	T
213TC/215TC						V	V	V	V
Kit Number	<input type="checkbox"/> B02	<input type="checkbox"/> B03/04	<input type="checkbox"/> B03/04	<input type="checkbox"/> B05	<input type="checkbox"/> B06	<input type="checkbox"/> B08/10	<input type="checkbox"/> B08/10	<input type="checkbox"/> B08/10	<input type="checkbox"/> B11

### Double Reduction Units

Unit Size					
B0520	B0620	B0820	B0920	B1010	B1120
U	U	T	T	T	T
W	W	V	V	V	V
		X	X	X	X
<input type="checkbox"/> B02	<input type="checkbox"/> B02	<input type="checkbox"/> B03/04	<input type="checkbox"/> B03/04	<input type="checkbox"/> B05	<input type="checkbox"/> B05

## Metric Iec Motor Adaptor Kits

### Single Stage Units

Motor Frame	Unit Size								
	B0210	B0310	B0410	B0510	B0610	B0810	B0910	B1010	B1110
63D	F	M	M	M	M				
71D	G	D	D	D	D				
71C	H	E	E	E	E				
80D	-	F	F	F	F	W	W	W	W
80C	J	G	G	G	G	X	X	X	X
90D		H	H	H	H	Y	Y	Y	Y
90C		J	J	J	J	Z	Z	Z	Z
100D/112D				K	K	A	A	A	A
100C/112C				L	L	B	B	B	B
132D						N	N	N	N
132C						C	C	C	C
Kit Number	<input type="checkbox"/> B02	<input type="checkbox"/> B03/04	<input type="checkbox"/> B03/04	<input type="checkbox"/> B05	<input type="checkbox"/> B06	<input type="checkbox"/> B08/10	<input type="checkbox"/> B08/10	<input type="checkbox"/> B08/10	<input type="checkbox"/> B11

### Double Reduction Units

Unit Size					
B0520	B0620	B0820	B0920	B1010	B1120
F	F	M	M	M	M
G	G	D	D	D	D
H	H	E	E	E	E
-	-	F	F	F	F
J	J	G	G	G	G
		H	H	H	H
		J	J	J	J
				K	K
				L	L
<input type="checkbox"/> B02	<input type="checkbox"/> B02	<input type="checkbox"/> B03/04	<input type="checkbox"/> B03/04	<input type="checkbox"/> B05	<input type="checkbox"/> B05

UNIT SIZE	INPUT SHAFT TYPE
	INCH
B02	B0210-X
B03	B03/0610-X
B04	B03/0610-X
B05	B03/0610-X
B06	B03/0610-X
B08	B08/1010-X
B09	B08/1010-X
B10	B08/1010-X
B11	B1110-X

## Solid Output Shaft Kits

Unit Size	INCH SINGLE EXTENDED	INCH DOUBLE EXTENDED
B02	B02-0N	B02-0P
B03	B03-0N	B03-0P
B04	B04-0N	B04-0P
B05	B05-0N	B05-0P
B06	B06-0N	B06-0P
B08	B08-0N	B08-0P
B09	B09-0N	B09-0P
B10	B10-0N	B10-0P
B11	B11-0N	B11-0P

UNIT SIZE	REDUCED DIAMETER OUTPUT SHAFT KITS	
	INCH SINGLE EXTENDED	INCH DOUBLE EXTENDED
B02	B02-0Q	B02- 0R
B04	B04-0Q	B04- 0R
B05	B05-0Q	B05- 0R
B08	B08-0Q	B08- 0R
B09	B09-0Q	B09- 0R
B10	B10-0Q	B10- 0R
B11	B11-0Q	B11- 0R

## Bolt On Base Kits

UNIT SIZE	STANDARD BASE KITS				
	HORIZONTAL BASE	VERTICAL BASE (HIGH)	VERTICAL BASE (LOW)	END MOUNT BASE	RISER BLOCKS
B02	B02-BE	B02-HE	B02-LE	B02-JE	B02-RB
B03	B03-BE	B03-HE	B03-LE	B03-JE	B03-RB
B04	B04-BE	B04-HE	B04-LE	B04-JE	B04-RB
B05	B05-BE	B05-HE	B05-LE	B05-JE	B05-RB
B06	B06-BE	B06-HE	B06-LE	B06-JE	B06-RB
B08	B08-BE	B08-HE	B08-LE	B08-JE	B08-RB
B09	B09-BE	B09-HE	B09-LE	B09-JE	B09-RB
B10	B10-BE	B10-HE	B10-LE	B10-JE	B10-RB
B11	B11-BE	B11-HE	B11-LE	B11-JE	B11-RB

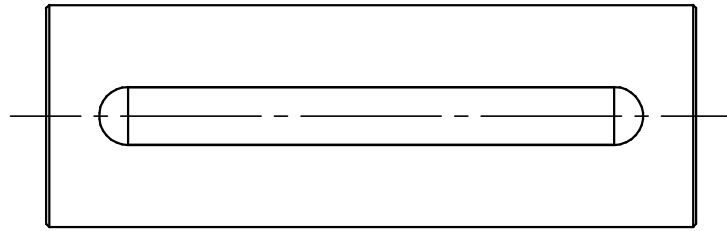
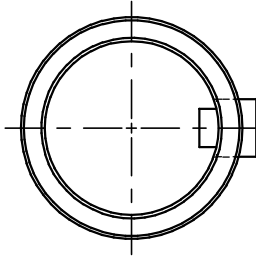

Inch Series

Unit Size	Shaft Dia (in)	Shaft Keyseat (in)	Kit No.
B02	5/8	3/16 x 1/16 x 3	B02-EB
B03	5/8	3/16 x 1/16 x 3	B03-EB
	7/8	3/16 x 1/16 x 3	B03-FB
B04	7/8	3/16 x 1/16 x 3.16	B04-EB
	1	1/4 x 3/32 x 3.15	B04-FB
	1-1/8	1/4 x 3/32 x 3.15	B04-GB
	1-1/4	1/4 x 3/32 x 3.15	B04-JB
B05	1	1/4 x 3/32 x 3.15	B05-EB
	1-1/8	1/4 x 3/32 x 3.15	B05-FB
	1-3/16	1/4 x 3/32 x 3.15	B05-GB
	1-1/4	1/4 x 3/32 x 3.15	B05-JB
B06	1	1/4 x 3/32 x 3.15	B06-EB
	1-1/8	1/4 x 3/32 x 3.15	B06-FB
	1-3/16	1/4 x 3/32 x 3.15	B06-GB
	1-1/4	1/4 x 3/32 x 3.15	B06-JB
B08	1-1/8	1/4 x 3/32 x 4.10	B08-EB
	1-7/16	3/8 x 1/8 x 4.10	B08-JB
B09	1-7/16	3/8 x 1/8 x 4.10	B09-EB
	1-3/4	3/8 x 1/8 x 4.10	B09-FB
	1-15/16	1/2 x 3/16 x 4.10	B09-GB
B10	1-7/16	3/8 x 1/8 x 4.50	B10-EB
	1-3/4	3/8 x 1/8 x 4.50	B10-FB
	1-15/16	1/2 x 3/16 x 4.50	B10-GB
B11	1-7/16	3/8 x 1/8 x 5.50	B11-EB
	2-3/16	1/2 x 3/16 x 5.50	B11-GB
	2-7/16	5/8 x 7/32 x 5.50	B11-JB

# Series B

# Output Bracket & Torque Arm Mount Kits

## Output Bracket & Torque Arm Mount Kits

UNIT SIZE	KIT NUMBERS	
	STANDARD OUTPUT BRACKET	STANDARD TORQUE ARM MOUNT
B02	B0210-BK	B0210-TA
B03	B0310-BK	B0310-TA
B04	B0410-BK	B0410-TA
B05	B0510-BK	B0510-TA
B06	B0610-BK	B0610-TA
B08	B0810-BK	B0810-TA
B09	B0910-BK	B0910-TA
B10	B1010-BK	B1010-TA
B11	B1110-BK	B1110-TA

# Series B

# Double Reduction Units - Mounting Kits

## Double Reduction Unit Size Breakdown

SIZE	B0520	B0620	B0820	B0920	B1020	B1120
Primary	B0210	B0210	B0410	B0410	B0510	B0510
Secondary	B0510	B0610	B0810	B0910	B1010	B1110

## Double Reduction Ratio Breakdown - Typical For Each Size

Overall Double Reduction Ratio	Primary Ratio	Secondary Ratio
100	5	20
150	7.5	20
200	10	20
300	15	20
400	20	20
500	25	20
600	30	20
800	40	20
1000	50	20
1200	60	20
1500	25	60
1800	30	60
2400	40	60
3000	50	60
3600	60	60

## Double Reduction Unit Mounting / Connecting Kit

Unit Size	Kit No.
B0520	B02-05CON-A
B0620	B02-06CON-A
B0820	B04-09CON-A
B0920	B04-09CON-A
B1020	B05-11CON-A
B1120	B05-11CON-A



**IMPORTANT****Product Safety Information**

**General** - The following information is important in ensuring safety. It **must** be brought to the attention of personnel involved in the selection of power transmission equipment, those responsible for the design of the machinery in which it is to be incorporated and those involved in its installation, use and maintenance.

Our power transmission equipment will operate safely provided it is selected, installed, used and maintained properly. As with any power transmission equipment **proper precautions must** be taken as indicated in the following paragraphs, to ensure safety.

**Potential Hazards** - these are **not** necessarily listed in any order of severity as the degree of danger varies in individual circumstances. It is important therefore that the list is studied in its entirety:-

- 1) Fire/Explosion
  - (a) Oil mists and vapour are generated within gear units. It is therefore dangerous to use naked lights in the proximity of gearbox openings, due to the risk of fire or explosion.
  - (b) In the event of fire or serious overheating (over (over 570 °F (300 °C)), certain materials (rubber, plastics, etc.) may decompose and produce fumes. Care should be taken to avoid exposure to the fumes, and the remains of burned or overheated plastic/rubber materials should be handled with rubber gloves.
- 2) Guards - Rotating shafts and couplings must be guarded to eliminate the possibility of physical contact or entanglement of clothing. It should be of rigid construction and firmly secured.
- 3) Noise - High speed gearboxes and gearbox driven machinery may produce noise levels which are damaging to the hearing with prolonged exposure. Ear defenders should be provided for personnel in these circumstances. Reference should be made to state and federal regulations for reducing exposure of employed persons to noise.
- 4) Lifting - Where provided (on larger units) only the lifting points or eyebolts must be used for lifting operations (see maintenance manual or general arrangement drawing for lifting point positions). Failure to use the lifting points provided may result in personal injury and/or damage to the product or surrounding equipment. Keep clear of raised equipment.
- 5) Lubricants and Lubrication
  - (a) Prolonged contact with lubricants can be detrimental to the skin. The manufacturer's instruction must be followed when handling lubricants.
  - (b) The lubrication status of the equipment must be checked before commissioning. Read and carry out all instructions on the lubricant plate and in the installation and maintenance literature. Heed all warning tags. Failure to do so could result in mechanical damage and in extreme cases risk of injury to personnel.
- 6) Electrical Equipment - Observe hazard warnings on electrical equipment and isolate power before working on the gearbox or associated equipment, in order to prevent the machinery being started.
- 7) Installation, Maintenance and Storage
  - (a) In the event that equipment is to be held in storage, for a period exceeding 6 months, prior to installation or commissioning, we must be consulted regarding special preservation requirements. Unless otherwise agreed, equipment must be stored in a building protected from extremes of temperature and humidity to prevent deterioration.  
The rotating components (gears and shafts) must be turned a few revolutions once a month (to prevent bearings brinelling).
  - (b) External gearbox components may be supplied with preservative materials applied, in the form of a "waxed" tape overwrap or wax film preservative. Gloves should be worn when removing these materials. The former can be removed manually, the latter using white spirit as a solvent.  
Preservatives applied to the internal parts of the gear units do not require removal prior to operation.
  - (c) Installation must be performed in accordance with the manufacturer's instructions and be undertaken by suitably qualified personnel.
  - (d) Before working on a gearbox or associated equipment, ensure that the load has been removed from the system to eliminate the possibility of any movement of the machinery and isolate power supply. Where necessary, provide mechanical means to ensure the machinery cannot move or rotate. Ensure removal of such devices after work is complete.
  - (e) Ensure the proper maintenance of gearboxes in operation. Use only the correct tools and our approved spare parts for repair and maintenance. Consult the Maintenance Manual before dismantling or performing maintenance work.
- 8) Hot Surfaces and Lubricants
  - (a) During operation, gear units may become sufficiently hot to cause skin burns. Care must be taken to avoid accidental contact.
  - (b) After extended running the lubricant in gear units and lubrication systems may reach temperatures sufficient to cause burns. Allow equipment to cool before servicing or performing adjustments.
- 9) Selection and Design
  - (a) Where gear units provide a backstop facility, ensure that back-up systems are provided if failure of the backstop device would endanger personnel or result in damage.
  - (b) The driving and driven equipment must be correctly selected to ensure that the complete machinery installation will perform satisfactorily, avoiding system critical speeds, system torsional vibration, etc.
  - (c) The equipment must not be operated in an environment or at speeds, powers, torques or with external loads beyond those for which it was designed.
  - (d) As improvements in design are being made continually the contents of this catalog are not to be regarded as binding in detail, and drawings and capacities are subject to alterations without notice.

The above guidance is based on the current state of knowledge and our best assessment of the potential hazards in the operation of the gear units.

Any further information or clarification required may be obtained by contacting our Application Engineers.





**Cone Drive Operations, Inc.**

240 East 12th Street  
Traverse City, Michigan 49684  
USA

**Cone Drive Operations, Ltd.**

1 Redwood Crescent, Peel Park  
East Kilbride G74 5PA  
UK

**H-Fang**

A Cone Drive Company  
No. 20 Yungu Road  
Changshou  
Zhouzhuang Town, Jiangyin  
Jiangsu PR China 214424