



ACCUDRIVE

SERIES LE & P

Precision. Motion Control. Technology.



Cone Drive is a world leader in precision motion control technology.

We work with our customers every step of the way – from design specs to the final solution – to create highly precise, highly specific products that keep our customers' technology at the forefront of their industry. Cone Drive offers engineering support, unique solutions, and innovative technology across a breadth of markets and products to drive your company forward.



TABLE OF CONTENTS

ACCUDRIVE SERIES LE & P

ONLINE CONFIGURATOR	4
ACCUDRIVE PRECISION PRODUCTS	6
SERIES LE DESIGN FEATURES	9
SERIES LE UNIT DESIGNATION	10
SERIES LE MOTOR MOUNTING CODES	11
SERIES LE OUTPUT TORQUE RATINGS	13
SERIES LE GENERAL SPECIFICATIONS	14
SERIES LE RADIAL AND AXIAL SHAFT LOAD RATINGS	15
SERIES LE INERTIA VALUES	16
SERIES LE DIMENSIONS	17
SERIES P - N TYPE DESIGN FEATURES	18
SERIES P - N TYPE UNIT DESIGNATION	19
SERIES P - N TYPE MOTOR MOUNTING CODES	20
SERIES P - N TYPE OUTPUT TORQUE RATINGS	22
SERIES P - N TYPE GENERAL SPECIFICATIONS	23
SERIES P - N TYPE RADIAL AND AXIAL SHAFT LOAD RATINGS	24
SERIES P - N TYPE INERTIA VALUES	25
SERIES P - N TYPE DIMENSIONS	26
SERIES P - S TYPE DESIGN FEATURES	27
SERIES P - S TYPE UNIT DESIGNATION	28
SERIES P - S TYPE MOTOR MOUNTING CODES	29
SERIES P - S TYPE OUTPUT TORQUE RATINGS	31
SERIES P - S TYPE GENERAL SPECIFICATIONS	32
SERIES P - S TYPE RADIAL AND AXIAL SHAFT LOAD RATINGS	33
SERIES P - S TYPE INERTIA VALUES	34
SERIES P - S TYPE DIMENSIONS	35
INSTALLATION, OPERATION, AND MAINTENANCE INSTRUCTIONS	36

Configure Your Accudrive Online

www.ConeTools.com

The screenshot shows the Cone Drive website's configuration tool. At the top, there's a navigation bar with the Cone Drive logo and links for Cone Drive, Cone Tools, and Contact. The main header features a large image of a slewing solution with the text "Cone Drive SLEWING SOLUTIONS" and a "CONFIGURE" button. Below this, a paragraph describes the products as low-profile, self-retaining, and durable. A secondary image shows a yellow crane. The main content area is titled "Servo Rated" and contains six product cards, each with an image, a title, a "CONFIGURE" button, and a brief description:

- AccuMate Servo**: Guided selection of AccuDrive products starting with Servo motor.
- AccuDrive - Series S**: A flexible and economical servo interfacing right angle gearbox solution.
- AccuDrive - Series W**: A high precision, high torque capacity right angle servo interfacing gearbox solution with a range of backlash options.
- AccuDrive - RG Servo**: A moderate precision, high torque capacity servo or NEMA interfacing right angle gearbox solution.
- Accudrive - Inline**: In-line servo interfacing precision planetary gearboxes.
- Model HP Servo**: High torque and high shock load capacity servo interfacing right angle gearbox solution.



Visit ConeTools.com
and Click
"Accudrive - Inline"

AccuMate[®]

SERVO GEARHEAD SELECTION PROGRAM

Our AccuMate[®] program helps you select the right servo gearbox for your application.

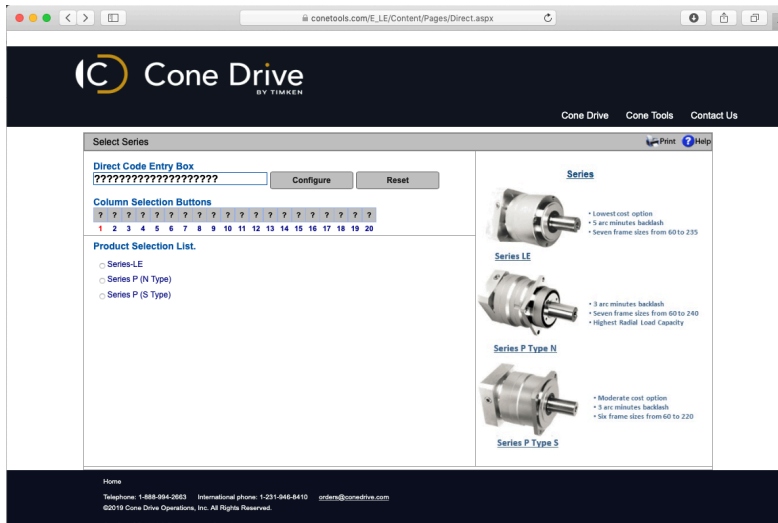

2
Select a product or enter in the Direct Code and click Configure

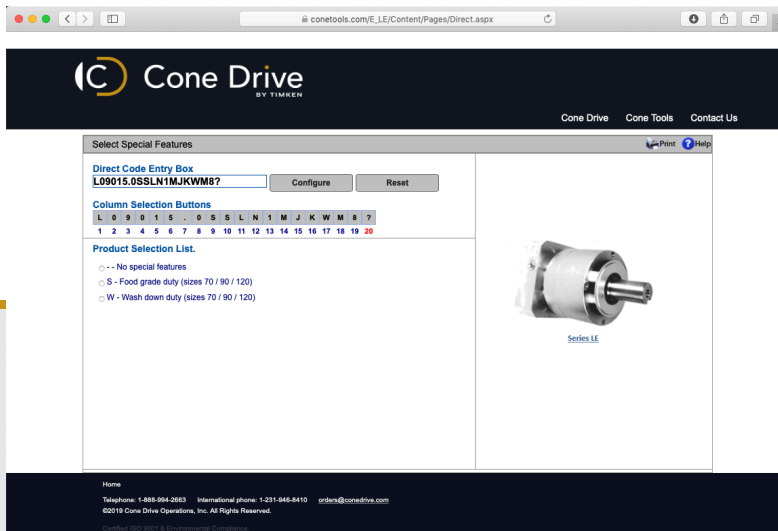

3
Select Motor Information and proceed to additional selections

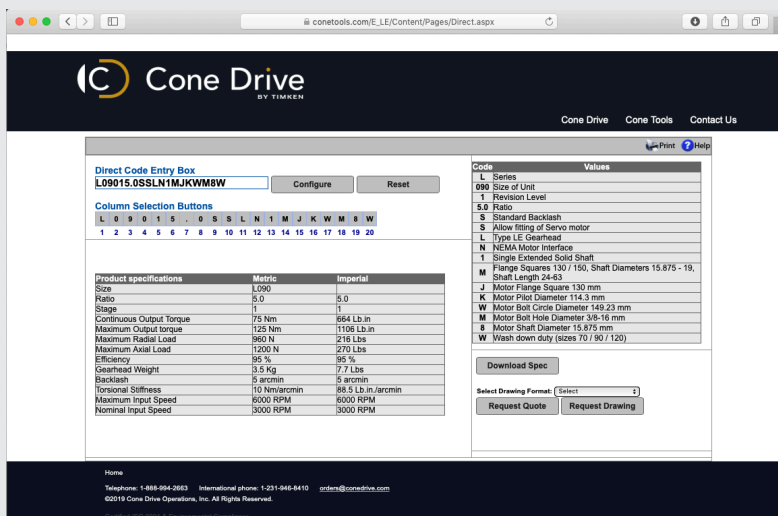

4
On final screen download the specifications or request a quote and drawing

Design flexibility and lasting performance with our complete family of Accudrive Precision Products.

SERIES RG RIGHT ANGLE GEARBOX

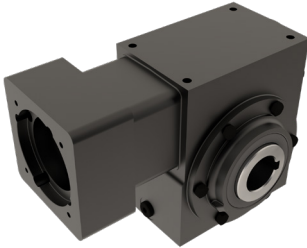

- Output torque capacity up to 8,500 lb.in.
- Motor sizes (standard), adapters to fit servo motors, NEMA and IEC
- Center distance 1.5 to 3.5 inches
- Input power ratings up to 27 H.P, speed range up to 4,000 RPM
- Sizes available 15, 20, 25, 30 and 35
- Universal Mounting with shaft mount and flange mount standard in single reduction type
- Gear ratios from 5:1 to 60:1

SERIES S SERVO GEARBOX

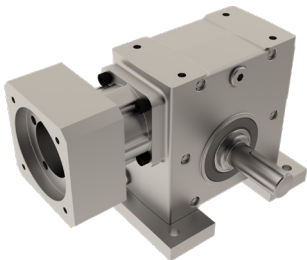

- Economical Servo Solution
- Output torque up to 7,540 lb.in.
- Motor adapters to fit servo motors
- Center distance from 1.33 inch up to 3.54 inch
- Speed range up to 4,000 RPM
- Flexible mounting (hollow output standard with plug in solid shaft)
- Ratios from 5:1 to 60:1

SERIES W PRECISION RIGHT ANGLE GEARBOX

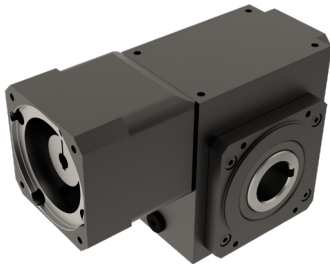

- Precision right angle reducers for low to medium power range requirements
- Motor adapters to fit most servo motors
- Features power capabilities of up to 25 HP
- Output torque capacity of up to 10,000 lb.in.
- Sizes (Center distance-mm): 38, 51, 64, 76, 89
- Speed range up to 6,000 RPM
- Ratios from 5:1 to 60:1 or custom ratios
- Input Options: Solid shaft, NEMA + Servo motor interfaces
- Output Shaft Options: Solid, hollow shaft, shrink disc; end mount
- Backlash Options: Standard, low or zero backlash
- Mounting Options: Universal mounting

ABSOLUTE ZERO BACKLASH ACCUDRIVE GEARING



- Unique design captures both sides of the gear tooth to completely eliminate backlash. Automatically compensates for wear-guaranteed zero backlash for the life of the gear. Available for single, double and triple reduction types, gear sets, special designs and the Series W.

Design flexibility and lasting performance with our complete family of Accudrive Precision Products.

SERIES LE IN-LINE PLANETARY SERVO GEARBOX



- Output torque capacity up to 7,080 lb.in.
- Speed range up to 6,000 RPM input
- Sizes 50, 70, 90, 120, 155, 205, 235
- Gear ratios from 3:1 to 100:1
- Universal Mounting with shaft mount and flange mount standard
- Backlash as low as 5 arc-minutes

SERIES P IN-LINE PLANETARY SERVO GEARBOX

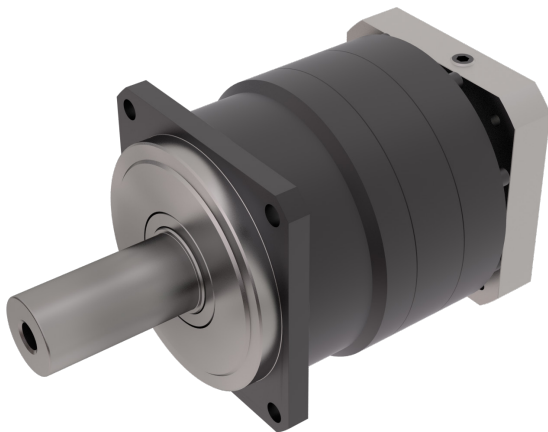

- Output torque capacity up to 21,240 lb.in. (2,400 Nm)
- Speed range up to 6,000 RPM input
- Sizes available 60, 90, 115, 140, 180, 220 (S-Type)
- Sizes available 60, 75, 100, 140, 180, 210, 240 (N-Type)
- Gear ratios from 3:1 to 100:1 available from stock (S-Type & N-Type)
- Universal Mounting with shaft mount and flange mount standard
- 3 arc-minutes backlash or better

Serving an entire spectrum of mechanical drive applications from food, energy, mining and metal; to automotive, aerospace and marine propulsion, we are your source for drive solutions.

INDUSTRIAL SOLUTIONS

SERIES HP

Worm gearbox with double-enveloping worm gearing. Available in single, double and triple reductions



SERIES HP-A

Universal metric housing featuring double-enveloping gearing & drywell feature



SERIES B

Industrial duty worm gearbox featuring Conex gearing

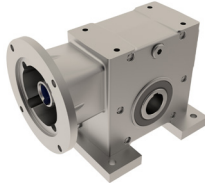

DUO DRIVE

Dual gears on parallel output shafts



SLEW SOLUTIONS

Versatile slew bearings and slew drives featuring external, internal and without teeth options in a low profile, ready-to-install package



STAINLESS

Right angle, IP-69K rated for the food processing market



DOUBLE-ENVELOPING WORM GEAR SET

Available in standard sizes, ratios and backlash options along with custom worm gear sets.



PRECISION MOTION SOLUTIONS

SERIES W

Precision right angle servo gearbox

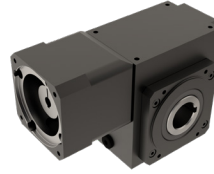

SERIES RG

Moderate precision right angle servo gearbox

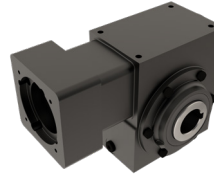

SERIES S

Value engineered right angle servo gearbox

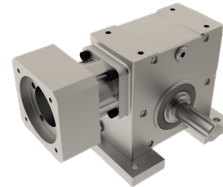

SERIES LE / P

In-line helical geared motors & reducers and precision planetary servo gearbox



HARMONIC

Cone Drive Harmonic Solutions® offer the ultimate in precision motion control technology

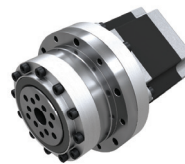

STAINLESS SERVO

Smooth, contoured stainless steel housing (316), IP69K rated right angle gearbox



HP SERVO

This double-enveloping worm gearing, high torque gearbox meets the most demanding needs as servo motor capacities increase



We can create custom engineered transmission solutions of any size and configuration.

ACCUDRIVE SERIES LE

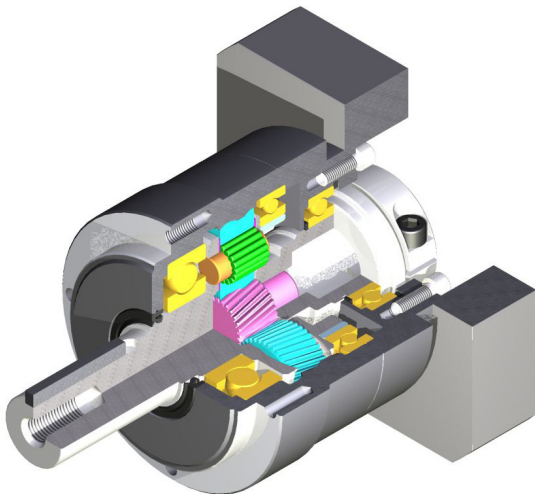

The Series LE has expanded range of sizes now from size 50 up to the size 235.

- Precision clamping system to eliminate motor shaft slipping.
- Integral output shaft and planet carrier.
- Grease lubricated for life.
- Improved lower backlash.
- Helical cut gears for reduced noise.

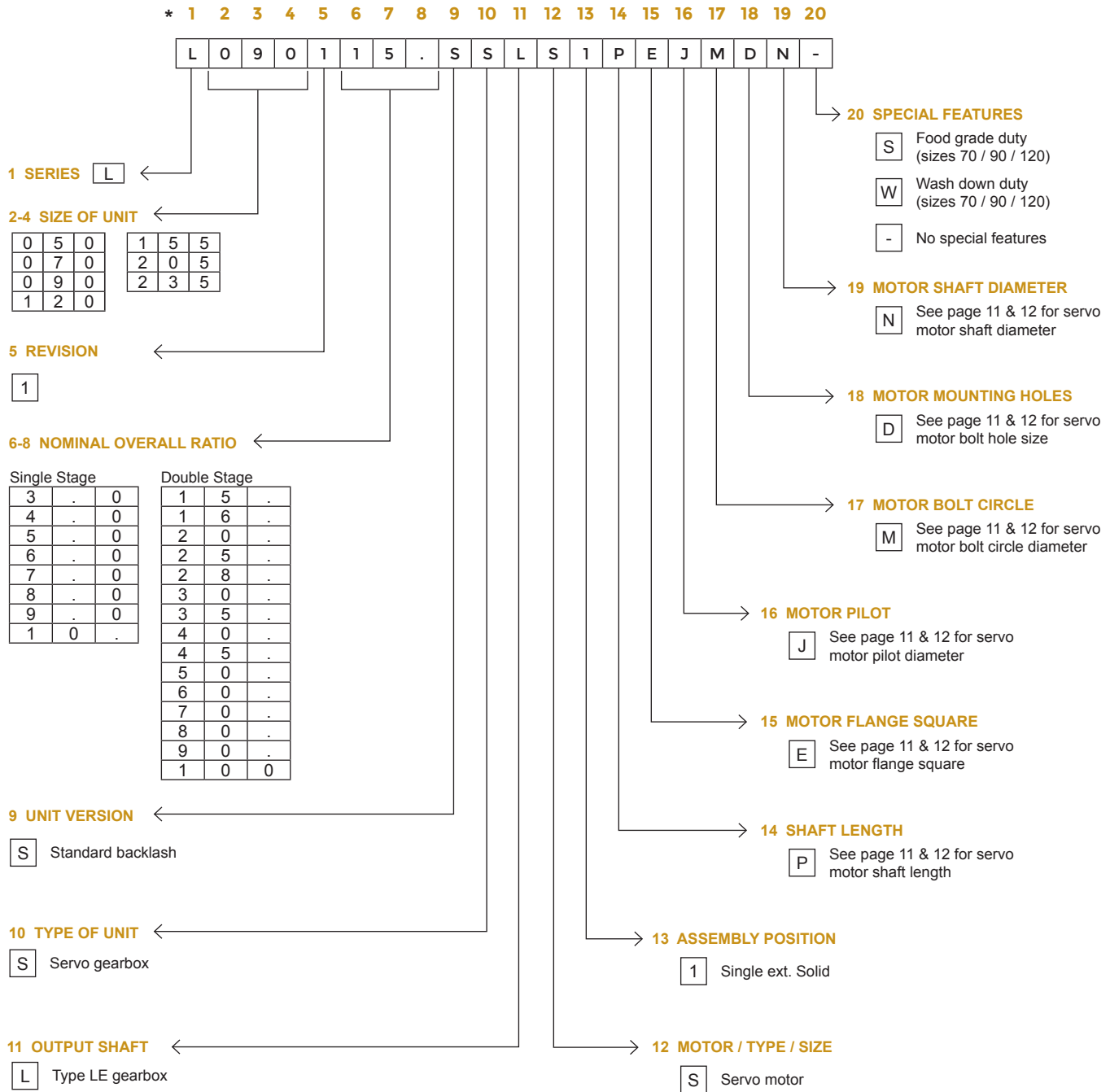

Wash down duty includes:

IP65 Ratings / Stainless output shaft and fasteners / Sealed bearing at the input / 2-part epoxy sealant

Food grade duty includes:

IP65 Ratings / Stainless output shaft and fasteners / Sealed bearing at the input / 2-part epoxy sealant / White epoxy paint

Wash down and food grade are standard options for sizes 70 / 90 / 120 and as a special for sizes 50 / 155 / 205 / 235.

We reserve the right to improve or change product design and specifications without notice.

LE50 SELECTIONS

COLUMN 14 ENTRY	SHAFT LENGTH RANGE BASED ON MOTOR SHAFT DIAMETER																								
	MOTOR FLANGE SQ.		42 / 60				65																		
	MOTOR SHAFT Ø		≤ Ø 8 mm				≤ Ø 14 mm																		
	MOTOR SHAFT LENGTH RANGE		MIN	MAX	MIN	MAX	MIN	MAX	MIN	MAX	MIN	MAX													
COLUMN 14 ENTRY		18	35	20	43																				
		A				B																			
FLANGE SQUARE																									
42		60		65																					
F		P		L																					
PILOT DIAMETER																									
22		30		36		38.1		40		50		54		60		70		73.025		80		95		115	
N		T		P		A		B		C		Q		D		E		F		G		H		V	
BOLT CIRCLE																									
43.82		46		63		66.68		70		70.71		75		80		90		95		98.43		98.995		100	
B		V		A		C		D		S		E		F		G		H		J		T		K	
BOLT HOLE DIAMETER IN MOTOR FLANGE																									
3.4 - 4.4		4.5 - 5.2		5.3 - 6.3		6.4 - 8.3		8.4 - 10.3		#6 - 32		#8 - 32		M3		M6									
J		A		B		C		D		K		L		P		Q									
MOTOR SHAFT DIAMETER																									
Single Reduction		5		6		6.35		7		8		9		9.525		10		11		12		12.7		14	
		Y		Z		A		7		B		C		D		E		F		G		H		J	
Double Reduction		5		6		6.35		7		8		9		9.525		10		11		12		12.7		14	
		Y		Z		A		7		B		C		D		E		F		G		H		J	

LE70 SELECTIONS

COLUMN 14 ENTRY	SHAFT LENGTH RANGE BASED ON MOTOR SHAFT DIAMETER																																		
	MOTOR FLANGE SQ.		52 / 60 / 70				65 / 80 / 90				70				100 / 115				80 / 90 / 100																
	MOTOR SHAFT Ø		≤ Ø 8 mm				≤ Ø 14 mm				≤ Ø 14 mm				≤ Ø 19 mm				≤ Ø 19 mm																
	MOTOR SHAFT LENGTH RANGE		MIN	MAX	MIN	MAX	MIN	MAX	MIN	MAX	MIN	MAX	MIN	MAX	MIN	MAX	MIN	MAX	MIN	MAX															
COLUMN 14 ENTRY		18	35	20	43	20	43	20	38	20	33	24	58																						
		C				B				E				F				G																	
FLANGE SQUARE																																			
52		60		65		70		80		90		100		115																					
G		P		L		A		B		C		D		E																					
PILOT DIAMETER																																			
22		30		36		38.1		40		50		54		55.563		60		70		73.025		80		95		100		110		114.3		115			
N		T		P		A		B		C		Q		R		D		E		F		G		H		U		J		K		V			
BOLT CIRCLE																																			
43.82		46		63		66.68		70		70.71		75		80		90		95		98.43		98.995		100		115		125.73		130		145		165	
B		V		A		C		D		S		E		F		G		H		J		T		K		L		U		M		N		P	
BOLT HOLE DIAMETER IN MOTOR FLANGE																																			
3.4 - 4.4		4.5 - 5.2		5.3 - 6.3		6.4 - 8.3		8.4 - 10.3		10.4 - 12.4		#6 - 32		#8 - 32		3/8 - 16		M3		M6		M8													
J		A		B		C		D		E		K		L		M		P		Q		R													
MOTOR SHAFT DIAMETER																																			
Single Reduction		5		6		6.35		7		8		9		9.525		10		11		12		12.7		14		15.875		16		17		19			
		Y		Z		A		7		B		C		D		E		F		G		H		J		8		K		9		L			
Double Reduction		5		6		6.35		7		8		9		9.525		10		11		12		12.7		14		15.875		16		17		19			
		Y		Z		A		7		B		C		D		E		F		G		H		J		8		K		9		L			

LE90 SELECTIONS

COLUMN 14 ENTRY	SHAFT LENGTH RANGE BASED ON MOTOR SHAFT DIAMETER																																												
	MOTOR FLANGE SQ.		52 / 60 / 70				65 / 70 / 80 / 90 / 100				115 / 150				80 / 90 / 100 / 115				130 / 150				100 / 115				130				150														
	MOTOR SHAFT Ø		≤ Ø 8 mm				≤ Ø 14 mm				≤ Ø 14 mm				≤ Ø 19 mm				≤ Ø 19 mm				≤ Ø 28 mm				≤ Ø 28 mm				≤ Ø 28 mm														
	MOTOR SHAFT LENGTH RANGE		MIN	MAX	MIN	MAX	MIN	MAX	MIN	MAX	MIN	MAX	MIN	MAX	MIN	MAX	MIN	MAX	MIN	MAX	MIN	MAX	MIN	MAX	MIN	MAX	MIN	MAX	MIN	MAX															
COLUMN 14 ENTRY		18	35	20	43	20	43	20	48	24	58	24	58	24	63	27	65	27	65	27	80	32	85	32	85	32	85																		
		C				H				J				L				M				P				R				S															
FLANGE SQUARE																																													
52		60		65		70		80		90		100		115		130		150																											
G		P		L		A		B		C		D		E		J		K																											
PILOT DIAMETER																																													
22		30		36		38.1		40		50		54		55.563		60		63.5		70		73.025		80		95		100		110		114.3		115		130		180		200					
N		T		P		A		B		C		Q		R		D		S		E		F		G		H		U		J		K		V		L		M		W					
BOLT CIRCLE																																													
43.82		46		63		66.68		70		70.71		75		80		90		95		98.43		98.995		100		115		125.73		130		145		149.23		165		200		215					
B		V		A		C		D		S		E		F		G		H		J		T		K		L		U		M		N		W		P		Q		R					
BOLT HOLE DIAMETER IN MOTOR FLANGE																																													
3.4 - 4.4		4.5 - 5.2		5.3 - 6.3		6.4 - 8.3		8.4 - 10.3		10.4 - 12.4		12.5 - 15		#6 - 32		#8 - 32		3/8 - 16		M3		M6		M8																					
J		A		B		C		D		E		F		K		L		M		P		Q		R																					
MOTOR SHAFT DIAMETER																																													
Single Reduction		9		9.525		10		11		12		12.7		14		15.875		16		17		19		19.05		22		22.225		24		26		28											
		C		D		E		F		G		H		J		8		K		9		L		2		M		3		N		4		P											
Double Reduction		5		6		6.35		7		8		9		9.525		10		11		12		12.7		14		15.875		16		17		19		19.05		22		22.225		24		26		28	
		Y		Z		A		7		B		C		D		E		F		G		H		J		8		K		9		L		2		M		3		N		4		P	

LE120 SELECTIONS

COLUMN 14 ENTRY	SHAFT LENGTH RANGE BASED ON MOTOR SHAFT DIAMETER																																										
	MOTOR FLANGE SQ.		65 / 70 / 80 / 90 / 100				115 / 150				80 / 90 / 100 / 115				130 / 150				100 / 115				130				150				180				130 / 150				180				
	MOTOR SHAFT Ø		≤ Ø 14 mm				≤ Ø 14 mm				≤ Ø 19 mm				≤ Ø 19 mm				≤ Ø 28 mm				≤ Ø 28 mm				≤ Ø 28 mm				≤ Ø 38 mm				≤ Ø 38 mm								
	MOTOR SHAFT LENGTH RANGE		MIN	MAX	MIN	MAX	MIN	MAX	MIN	MAX	MIN	MAX	MIN	MAX	MIN	MAX	MIN	MAX	MIN	MAX	MIN	MAX	MIN	MAX	MIN	MAX	MIN	MAX	MIN	MAX	MIN	MAX	MIN	MAX									
COLUMN 14 ENTRY		20	43	20	48	24	58	24	63	27	65	27	80	32	85	32	85	32	85	32	85	32	85	32	85	32	85	32	85	32	85	32	85	32	85	32	85						
		H				J				L				M				P				R				S				T				U				W					
FLANGE SQUARE																																											
65		70		80		90		100		115		130		150		180																											
L		A		B		C		D		E		J		K		H																											
PILOT DIAMETER																																											
36		38.1		40		50		54		55.563		60		63.5		70		73.025		80		95		100		110		114.3		115		130		180		200		215.9		230			
P		A		B		C		Q		R		D		S		E		F		G		H		U		J		K		V		L		M		W		X		Y			
BOLT CIRCLE																																											
63		66.68		70		70.71		75		80		90		95		98.43		98.995		100		115		125.73		130		145		149.23		165		200		215		235		265			
A		C		D		S		E		F		G		H		J		T		K		L		U		M		N		W		P		Q		R		Z		7		8	
BOLT HOLE DIAMETER IN MOTOR FLANGE																																											
4.5 - 5.2		5.3 - 6.3		6.4 - 8.3		8.4 - 10.3		10.4 - 12.4		12.5 - 15		3/8 - 16		1/2 - 13		M6		M8																									
A		B		C		D		E		F		M		N		Q		R																									
MOTOR SHAFT DIAMETER																																											
Single Reduction		15.875		16		17		19		19.05		22		22.225		24		26		28		28.575		32		35		38															

Series LE Motor Mounting Codes

LE155 SELECTIONS

COLUMN 14 ENTRY	SHAFT LENGTH RANGE BASED ON MOTOR SHAFT DIAMETER																																	
	MOTOR FLANGE SQ.	80 / 90 / 100 / 115			130 / 150			100 / 115			130			150			180 / 200 / 220			130 / 150			180			200			220			180 / 200 / 220		
	MOTOR SHAFT Ø	≤ Ø 19 mm																																
	MOTOR SHAFT LENGTH RANGE	MIN	MAX	MIN	MAX	MIN	MAX	MIN	MAX	MIN	MAX	MIN	MAX	MIN	MAX	MIN	MAX	MIN	MAX	MIN	MAX	MIN	MAX	MIN	MAX	MIN	MAX	MIN	MAX					
COLUMN 14 ENTRY		24	58	24	63	27	65	27	80	32	85	32	75	37	80	42	115	42	90	42	95	40	116											
COLUMN 15 ENTRY	FLANGE SQUARE																																	
	80	90	100	115	130	150	180	200	220																									
	B	C	D	E	J	K	H	M	N																									
COLUMN 16 ENTRY	PILOT DIAMETER																																	
	55.563	60	63.5	70	73.025	80	95	100	110	114.3	115	130	180	200	215.9	230	250																	
	R	D	S	E	F	G	H	U	J	K	V	L	M	W	X	Y	Z																	
COLUMN 17 ENTRY	BOLT CIRCLE																																	
	90	98.43	100	115	125.73	130	145	149.23	165	184.15	200	215	220	235	250	265	300																	
	G	J	K	L	U	M	N	W	P	X	Q	R	Y	Z	7	8	9																	
COLUMN 18 ENTRY	BOLT HOLE DIAMETER IN MOTOR FLANGE																																	
	5.3 - 6.3	6.4 - 8.3	8.4 - 10.3	10.4 - 12.4	12.5 - 15	17 - 20	3/8 - 16	1/2 - 13	M8																									
	B	C	D	E	F	G	M	N	R																									
COLUMN 19 ENTRY	MOTOR SHAFT DIAMETER																																	
	Single Reduction	19.05	22	22.225	24	26	28	28.575	32	35	38	42	48																					
		2	M	3	N	4	P	5	Q	R	S	T	V																					
	Double Reduction	15.875	16	17	19	19.05	22	22.225	24	26	28	28.575	32	35	38	42	48																	
		8	K	9	L	2	M	3	N	4	P	5	Q	R	S	T	V																	

LE205 SELECTIONS

COLUMN 14 ENTRY	SHAFT LENGTH RANGE BASED ON MOTOR SHAFT DIAMETER																														
	MOTOR FLANGE SQ.	100 / 115			130			150			180 / 200 / 220			130 / 150			180			200			220			250			180 / 200 / 220 / 250 / 280		
	MOTOR SHAFT Ø	≤ Ø 28 mm																													
	MOTOR SHAFT LENGTH RANGE	MIN	MAX	MIN	MAX	MIN	MAX	MIN	MAX	MIN	MAX	MIN	MAX	MIN	MAX	MIN	MAX	MIN	MAX	MIN	MAX	MIN	MAX	MIN	MAX	MIN	MAX				
COLUMN 14 ENTRY		27	65	27	80	32	85	32	75	37	80	42	115	42	90	42	95	42	80	40	116										
COLUMN 14 ENTRY	P			R			S			T			U			W			X			Y			Z						
COLUMN 15 ENTRY	FLANGE SQUARE																														
	100	115	130	150	180	200	220	250	280																						
	D	E	J	K	H	M	N	Q	R																						
COLUMN 16 ENTRY	PILOT DIAMETER																														
	55.563	63.5	80	95	110	114.3	130	180	200	215.9	230	250	300																		
	R	S	G	H	J	K	L	M	W	X	Y	Z	7																		
COLUMN 17 ENTRY	BOLT CIRCLE																														
	100	115	125.73	130	145	149.23	165	184.15	200	215	220	235	250	265	300	350															
	K	L	U	M	N	W	P	X	Q	R	Y	Z	7	8	9	2															
COLUMN 18 ENTRY	BOLT HOLE DIAMETER IN MOTOR FLANGE																														
	6.4 - 8.3	8.4 - 10.3	10.4 - 12.4	12.5 - 15	17 - 20	21 - 24	3/8 - 16	1/2 - 13	M8																						
	C	D	E	F	G	H	M	N	R																						
COLUMN 19 ENTRY	MOTOR SHAFT DIAMETER																														
	Single Reduction	28.575	32	35	38	42	45	48	55	60	65																				
		5	Q	R	S	T	U	V	W	X	6																				
	Double Reduction	19.05	22	22.225	24	26	28	28.575	32	35	38	42	45	48																	
		2	M	3	N	4	P	5	Q	R	S	T	U	V																	

LE235 SELECTIONS

COLUMN 14 ENTRY	SHAFT LENGTH RANGE BASED ON MOTOR SHAFT DIAMETER																										
	MOTOR FLANGE SQ.	130 / 150			180			200			220			250			180 / 200 / 220 / 250 / 280			250 / 280			320				
	MOTOR SHAFT Ø	≤ Ø 38 mm																									
	MOTOR SHAFT LENGTH RANGE	MIN	MAX	MIN	MAX	MIN	MAX	MIN	MAX	MIN	MAX	MIN	MAX	MIN	MAX	MIN	MAX	MIN	MAX	MIN	MAX	MIN	MAX				
COLUMN 14 ENTRY		37	80	42	115	42	90	42	95	42	80	40	116	40	116	40	120	54	150	74	140						
COLUMN 14 ENTRY	U			W			X			Y			2			Z			4			6			8		
COLUMN 15 ENTRY	FLANGE SQUARE																										
	130	150	180	200	220	250	280	320																			
	J	K	H	M	N	Q	R	T																			
COLUMN 16 ENTRY	PILOT DIAMETER																										
	95	110	114.3	130	180	200	215.9	230	250	300																	
	H	J	K	L	M	W	X	Y	Z	7																	
COLUMN 17 ENTRY	BOLT CIRCLE																										
	130	145	165	184.15	200	215	235	250	265	300	350																
	M	N	P	X	Q	R	Z	7	8	9	2																
COLUMN 18 ENTRY	BOLT HOLE DIAMETER IN MOTOR FLANGE																										
	8.4 - 10.3	10.4 - 12.4	12.5 - 15	17 - 20	21 - 24	1/2 - 13	M8																				
	D	E	F	G	H	N	R																				
COLUMN 19 ENTRY	MOTOR SHAFT DIAMETER																										
	Single Reduction	42	45	48	55	60	65																				
		T	U	V	W	X	6																				
	Double Reduction	28.575	32	35	38	42	45	48																			
		5	Q	R	S	T	U	V																			

OUTPUT TORQUE BY GEARBOX SIZE															
RATIOS	UNITS	LE 50		LE 70		LE 90		LE 120		LE 155		LE 205		LE 235	
		T_{2N}	T_{2ACC}	T_{2N}	T_{2ACC}	T_{2N}	T_{2ACC}	T_{2N}	T_{2ACC}	T_{2N}	T_{2ACC}	T_{2N}	T_{2ACC}	T_{2N}	T_{2ACC}
3	Nm	6	12	18	35	50	80	120	225	240	470	500	970	1000	1600
4		9	18	27	50	75	125	120	330	240	700	750	1400	1500	2300
5		9	18	27	50	75	125	180	330	360	700	750	1400	1500	2300
6		9	18	27	50	75	125	180	330	360	700	750	1400	1500	2300
7		9	18	27	50	75	125	180	330	360	700	750	1400	1500	2300
8		9	18	27	50	75	125	180	330	360	700	750	1400	1500	2200
9		6	12	18	35	50	80	120	225	240	470	500	970	1000	1900
10		6	12	18	35	50	80	120	225	240	470	500	970	1000	1600
15		6	12	18	35	50	80	120	225	240	470	500	970	1000	1600
16		9	18	27	50	75	125	180	330	360	700	750	1400	1500	2300
20		9	18	27	50	75	125	180	330	360	700	750	1400	1500	2300
25		9	18	27	50	75	125	180	330	360	700	750	1400	1500	2300
28		9	18	27	50	75	125	180	330	360	700	750	1400	1500	2300
30		9	12	18	35	50	80	120	225	240	470	500	970	1000	1600
35		9	18	27	50	75	125	180	330	360	700	750	1400	1500	2300
40		9	18	27	50	75	125	180	330	360	700	750	1400	1500	2300
45		6	12	18	35	50	80	120	225	240	470	500	970	1000	1300
50		9	18	27	50	75	125	180	330	360	700	750	1400	1500	2300
60		9	18	27	50	75	125	180	330	360	700	750	1400	1500	2300
70		9	18	27	50	75	125	180	330	360	700	750	1400	1500	2300
80	9	18	27	50	75	125	180	330	360	700	750	1400	1500	1800	
90	6	12	18	35	50	80	120	225	240	470	500	970	1000	1300	
100	6	12	18	35	50	80	120	225	240	470	500	970	1000	1200	

T_{2N} - At nominal input speed, service life is 20,000 hours

T_{2ACC} - The maximum torque during acceleration and deceleration

ATTRIBUTE	UNITS	GEAR STAGES	SIZE						
			LE 50	LE 70	LE 90	LE 120	LE 155	LE 205	LE 235
Emergency Stop Torque ¹	Nm	1 & 2	2 x T _{2ACC}						
Degree of Protection ²	—		IP54 (IP65 OPTIONAL)						
Nominal Input Speed ³	rpm		4000	3000	3000	3000	2000	1500	1000
Maximum Input Speed ⁴	rpm		8000	6000	6000	6000	4000	3000	2000
Permitted Housing Temperature	°C	—	90						
Efficiency ⁵	%	1	95	95	95	95	95	95	97
		2	90	90	90	90	90	90	92
Weight ⁶	kg	1	0.7	1.5	3.5	7.8	16	39	55
		2	0.8	1.7	4	8.7	18	40	57
Maximum Torsional Backlash	arc-min	1	≤ 5	≤ 5	≤ 5	≤ 5	≤ 5	≤ 5	≤ 5
		2	≤ 7	≤ 5	≤ 5	≤ 5	≤ 5	≤ 5	≤ 5
Torsional Rigidity ⁷	Nm/ arc-min	1	2	3	10	31	60	175	400
		2	2	3	10	31	60	175	400
Noise Level ⁸	dB	1	≤ 61	≤ 66	≤ 67	≤ 71	≤ 67	≤ 67	≤ 61
		2	≤ 61	≤ 66	≤ 67	≤ 71	≤ 67	≤ 67	≤ 61
No Load Running Torque ⁹	Nm	1	0.03	0.08	0.35	1.3	1.63	2.68	2.92
		2	0.01	0.04	0.06	0.42	0.56	1.39	1.14

1 The maximum torque allowed under a stress situation (Permitted 1,000 times during service life)

2 IP65 (wash-down) is available as an option. Contact Cone Drive for more details

3 The average input speed

4 The maximum intermittent input speed

5 The efficiency at the nominal output torque rating

6 The weight may vary slightly between models

7 This does not include backlash

8 Contact Cone Drive for the testing conditions and environment

9 Torque at no load applied to the input shaft at nominal input speed

PERMITTED RADIAL LOADS

RATIO	UNITS	GEAR STAGES	SIZE								
			Permitted Radial Load ¹								
			LE 50	LE 70	LE 90	LE 120	LE 155	LE 205	LE 235		
3	N	1	240	430	810	1300	3200	5600	5800		
4			270	470	890	1500	3500	6200	6400		
5			290	510	960	1600	3800	6700	6900		
6			310	540	1000	1700	4000	7100	7300		
7			320	570	1100	1800	4200	7400	7700		
8			340	600	1100	1900	4400	7800	8000		
9			350	620	1200	1900	4600	8100	8400		
10			360	640	1200	2000	4700	8400	8700		
15			N	2	410	740	1400	2300	5400	9600	9900
16					420	750	1400	2300	5500	9800	10000
20	460	810			1500	2500	6000	11000	11000		
25	490	870			1600	2700	6400	11000	12000		
28	510	910			1700	2800	6700	12000	12000		
30	520	930			1700	2900	6800	12000	13000		
35	550	980			1800	3000	7200	13000	13000		
40	570	1000			1900	3200	7500	13000	14000		
45	600	1100			2000	3300	7800	14000	14000		
50	620	1100			2100	3400	8100	14000	15000		
60	660	1200	2200	3600	8600	15000	15000				
70	690	1200	2300	3800	9100	15000	15000				
80	710	1200	2400	4000	9100	15000	15000				
90	710	1200	2400	4200	9100	15000	15000				
100	710	1200	2400	4300	9100	15000	15000				

¹ At this load and nominal input speed, service life will be 20,000 hours.
(The radial load applied to the output side shaft center)

PERMITTED AXIAL LOADS

RATIO	UNITS	GEAR STAGES	SIZE								
			Permitted Axial Load ²								
			LE 50	LE 70	LE 90	LE 120	LE 155	LE 205	LE 235		
3	N	1	270	310	930	1500	2400	4300	6400		
4			300	360	1100	1700	2700	4900	7200		
5			330	390	1200	1900	3000	5400	7900		
6			360	430	1300	2000	3300	5800	8600		
7			380	460	1300	2100	3500	6300	9200		
8			410	480	1400	2300	3700	6600	9700		
9			430	510	1500	2400	3900	7000	10000		
10			450	530	1600	2500	4100	7300	11000		
15			N	2	540	630	1900	3000	4900	8700	13000
16					550	650	1900	3100	5000	8900	13000
20	610	720			2100	3400	5500	9900	14000		
25	640	790			2200	3700	6100	11000	14000		
28	640	830			2200	3900	6400	11000	14000		
30	640	860			2200	3900	6600	12000	14000		
35	640	920			2200	3900	7000	13000	14000		
40	640	970			2200	3900	7500	13000	14000		
45	640	1000			2200	3900	7900	14000	14000		
50	640	1100			2200	3900	8200	14000	14000		
60	640	1100	2200	3900	8200	14000	14000				
70	640	1100	2200	3900	8200	14000	14000				
80	640	1100	2200	3900	8200	14000	14000				
90	640	1100	2200	3900	8200	14000	14000				
100	640	1100	2200	3900	8200	14000	14000				

² At this load and nominal input speed, service life will be 20,000 hours.
(The axial load applied to the output side bearing)

MAXIMUM RADIAL LOADS

RATIO	UNITS	GEAR STAGES	SIZE								
			Maximum Radial Load ¹								
			LE 50	LE 70	LE 90	LE 120	LE 155	LE 205	LE 235		
3	N	1	3000	4300	7000	10000	19000	24000	30000		
4			3000	4300	7000	10000	19000	24000	30000		
5			3000	4300	7000	10000	19000	24000	30000		
6			3000	4300	7000	10000	19000	24000	30000		
7			3000	4300	7000	10000	19000	24000	30000		
8			3000	4300	7000	10000	19000	24000	30000		
9			3000	4300	7000	10000	19000	24000	30000		
10			3000	4300	7000	10000	19000	24000	30000		
15			N	2	3000	4300	7000	10000	19000	24000	30000
16					3000	4300	7000	10000	19000	24000	30000
20	3000	4300			7000	10000	19000	24000	30000		
25	3000	4300			7000	10000	19000	24000	30000		
28	3000	4300			7000	10000	19000	24000	30000		
30	3000	4300			7000	10000	19000	24000	30000		
35	3000	4300			7000	10000	19000	24000	30000		
40	3000	4300			7000	10000	19000	24000	30000		
45	3000	4300			7000	10000	19000	24000	30000		
50	3000	4300			7000	10000	19000	24000	30000		
60	3000	4300	7000	10000	19000	24000	30000				
70	3000	4300	7000	10000	19000	24000	30000				
80	3000	4300	7000	10000	19000	24000	30000				
90	3000	4300	7000	10000	19000	24000	30000				
100	3000	4300	7000	10000	19000	24000	30000				

¹ The maximum radial load that the gearbox can accept at the center of the output shaft

MAXIMUM AXIAL LOADS

RATIO	UNITS	GEAR STAGES	SIZE								
			Maximum Axial Load ²								
			LE 50	LE 70	LE 90	LE 120	LE 155	LE 205	LE 235		
3	N	1	640	1100	2200	3900	8200	14000	14000		
4			640	1100	2200	3900	8200	14000	14000		
5			640	1100	2200	3900	8200	14000	14000		
6			640	1100	2200	3900	8200	14000	14000		
7			640	1100	2200	3900	8200	14000	14000		
8			640	1100	2200	3900	8200	14000	14000		
9			640	1100	2200	3900	8200	14000	14000		
10			640	1100	2200	3900	8200	14000	14000		
15			N	2	640	1100	2200	3900	8200	14000	14000
16					640	1100	2200	3900	8200	14000	14000
20	640	1100			2200	3900	8200	14000	14000		
25	640	1100			2200	3900	8200	14000	14000		
28	640	1100			2200	3900	8200	14000	14000		
30	640	1100			2200	3900	8200	14000	14000		
35	640	1100			2200	3900	8200	14000	14000		
40	640	1100			2200	3900	8200	14000	14000		
45	640	1100			2200	3900	8200	14000	14000		
50	640	1100			2200	3900	8200	14000	14000		
60	640	1100	2200	3900	8200	14000	14000				
70	640	1100	2200	3900	8200	14000	14000				
80	640	1100	2200	3900	8200	14000	14000				
90	640	1100	2200	3900	8200	14000	14000				
100	640	1100	2200	3900	8200	14000	14000				

² The maximum axial load that the gearbox can accept

RATIO UNITS		SIZE													
		LE 50		LE 70			LE 90				LE 120				
Motor Shaft Diameter		≤ Ø 8mm	≤ Ø 14mm	≤ Ø 8mm	≤ Ø 14mm	≤ Ø 19mm	≤ Ø 8mm	≤ Ø 14mm	≤ Ø 19mm	≤ Ø 28mm	≤ Ø 8	≤ Ø 14	≤ Ø 19	≤ Ø 28	≤ Ø 38
3	kgcm ²	0.053	0.17	0.14	0.25	0.53	-	0.72	1.1	2.9	-	-	3.2	5.1	12
4		0.041	0.16	0.095	0.21	0.48	-	0.5	0.9	2.7	-	-	2	3.7	10
5		0.036	0.15	0.077	0.19	0.46	-	0.41	0.8	2.6	-	-	1.4	3.1	9.5
6		0.034	0.15	0.068	0.18	0.46	-	0.36	0.75	2.5	-	-	1.2	2.9	9.3
7		0.032	0.15	0.062	0.17	0.45	-	0.33	0.73	2.5	-	-	1	2.8	9.1
8		0.031	0.15	0.059	0.17	0.45	-	0.31	0.71	2.5	-	-	0.92	2.7	9
9		0.031	0.15	0.057	0.17	0.44	-	0.3	0.7	2.5	-	-	0.86	2.6	8.9
10		0.030	0.15	0.056	0.17	0.44	-	0.3	0.7	2.5	-	-	0.83	2.6	8.9
15		0.035	-	0.064	0.18	0.45	0.2	0.36	0.75	2.5	-	0.77	1.2	2.9	9.2
16		0.038	-	0.07	0.18	0.46	0.25	0.41	0.79	2.5	-	0.98	1.4	3.1	9.4
20		0.034	-	0.062	0.17	0.45	0.19	0.35	0.74	2.5	-	0.72	1.1	2.8	9.1
25		0.034	-	0.061	0.17	0.45	0.19	0.35	0.74	2.5	-	0.7	1.1	2.8	9.1
28		0.038	-	0.068	0.18	0.46	0.24	0.4	0.78	2.5	-	0.92	1.3	3	9.3
30		0.030	-	0.051	0.16	0.44	0.12	0.28	0.67	2.4	-	0.38	0.78	2.5	8.8
35		0.034	-	0.061	0.17	0.45	0.18	0.35	0.73	2.5	-	0.68	1.1	2.8	9.1
40		0.030	-	0.051	0.16	0.44	0.11	0.28	0.67	2.4	-	0.37	0.77	2.5	8.8
45		0.034	-	0.061	0.17	0.45	0.18	0.34	0.73	2.5	-	0.68	1.1	2.8	9.1
50		0.030	-	0.051	0.16	0.44	0.11	0.27	0.67	2.4	0.19	0.36	0.76	2.5	8.8
60		0.030	-	0.051	0.16	0.44	0.11	0.27	0.67	2.4	0.19	0.36	0.76	2.5	8.8
70		0.030	-	0.051	0.16	0.44	0.11	0.27	0.67	2.4	0.19	0.36	0.76	2.5	8.8
80	0.030	-	0.051	0.16	0.44	0.11	0.27	0.67	2.4	0.19	0.36	0.76	2.5	8.8	
90	0.030	-	0.051	0.16	0.44	0.11	0.27	0.67	2.4	0.19	0.36	0.76	2.5	8.8	
100	0.030	-	0.051	0.16	0.44	0.11	0.27	0.67	2.4	0.19	0.36	0.76	2.5	8.8	

RATIO UNITS		SIZE													
		LE 155					LE 205					LE 235			
Motor Shaft Diameter		≤ Ø 14	≤ Ø 19	≤ Ø 28	≤ Ø 38	≤ Ø 48	≤ Ø 19	≤ Ø 28	≤ Ø 38	≤ Ø 48	≤ Ø 65	≤ Ø 28	≤ Ø 38	≤ Ø 48	≤ Ø 65
3	kgcm ²	-	-	12	18	35	-	-	43	57	110	-	-	110	160
4		-	-	7.3	14	29	-	-	26	41	85	-	-	54	98
5		-	-	5.3	12	27	-	-	19	34	78	-	-	42	85
6		-	-	4.3	11	26	-	-	15	31	75	-	-	35	79
7		-	-	3.9	10	25	-	-	14	29	73	-	-	33	76
8		-	-	3.5	9.9	25	-	-	13	28	72	-	-	30	74
9		-	-	3.3	9.7	25	-	-	12	27	71	-	-	29	73
10		-	-	3.2	9.6	25	-	-	12	27	71	-	-	28	72
15		-	2.6	4.4	11	26	-	8.8	15	30	-	-	20	34	-
16		-	3.5	5.3	12	27	-	11	18	33	-	-	24	39	-
20		-	2.4	4.2	10	25	-	8.1	14	29	-	-	19	33	-
25		-	2.4	4.1	10	25	-	7.9	14	29	-	-	18	33	-
28		-	3.3	5.1	11	26	-	11	17	32	-	-	23	37	-
30		-	1.1	2.9	9.2	24	-	4	10	25	-	-	12	26	-
35		-	2.3	4.1	10	25	-	7.6	14	29	-	-	18	32	-
40		-	1.1	2.8	9.1	24	-	3.9	10	25	-	-	12	26	-
45		-	2.3	4	10	25	-	7.6	14	29	-	-	18	32	-
50		0.65	1.1	2.8	9.1	24	1.9	3.8	10	25	-	4.7	12	26	-
60		0.64	1.1	2.8	9.1	24	1.9	3.8	10	25	-	4.7	11	26	-
70		0.64	1.1	2.8	9.1	24	1.8	3.8	10	25	-	4.6	11	26	-
80	0.63	1.1	2.8	9.1	24	1.8	3.7	10	25	-	4.6	11	26	-	
90	0.63	1.1	2.8	9.1	24	1.8	3.7	10	25	-	4.6	11	26	-	
100	0.63	1.1	2.8	9.1	24	1.8	3.7	10	25	-	4.6	11	26	-	

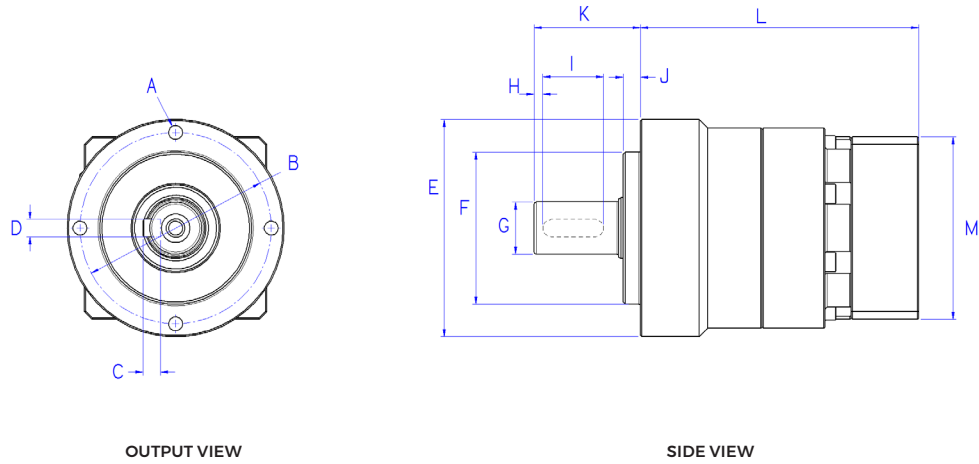

MODEL	UNITS	GEAR STAGES	INPUT BORE SIZE	L	M	A	B	C	D	E	F (g6)	G (g6)	H	I	J	K
LE 50		1	≤ Ø 8	64	42	M4 X 8	44	4	4	50	35	12	2	14	4	24.5
			≤ Ø 14	67	65											
		2	≤ Ø 8	80.5	42											
			≤ Ø 19	95	52											
LE 70		1	≤ Ø 8	76	52	M5 X 10	62	5	5	70	52	16	0	22	5	36
			≤ Ø 14	79	65											
		2	≤ Ø 14	100	65											
			≤ Ø 19	115	80											
LE 90		1	≤ Ø 14	97	65	M6 X 12	80	6	6	90	68	22	0	28	7	46
			≤ Ø 19	107	80											
		2	≤ Ø 8	114	52											
			≤ Ø 14	119	65											
			≤ Ø 19	129	80											
			≤ Ø 28	124	130											
LE 120	mm	1	≤ Ø 19	117	80	M8 X 16	108	8	10	120	90	32	0	45	9	70
			≤ Ø 28	134	130											
		2	≤ Ø 14	134.5	65											
			≤ Ø 19	144.5	80											
			≤ Ø 28	161.5	130											
			≤ Ø 38	155	180											
LE 155		1	≤ Ø 28	152	130	M10 X 20	140	8	12	155	120	40	0	65	12	97
			≤ Ø 38	167	180											
		2	≤ Ø 48	208	180											
			≤ Ø 19	169.5	80											
			≤ Ø 28	186.5	130											
			≤ Ø 38	201.5	180											
LE 205		1	≤ Ø 38	186.5	180	M12 X 22	184	10	16	205	160	55	0	65	15	100
			≤ Ø 48	222.5	180											
		2	≤ Ø 65	234	250											
			≤ Ø 28	216	130											
			≤ Ø 38	231	180											
			≤ Ø 48	267	180											
LE 235		1	≤ Ø 48	241.5	180	M16 X 28	210	12	20	235	180	75	0	85	18	126
			≤ Ø 65	245.5	250											
		2	≤ Ø 38	240.5	180											
			≤ Ø 48	276.5	180											

1 Length will vary depending on motor

ACCUDRIVE

SERIES P - N TYPE

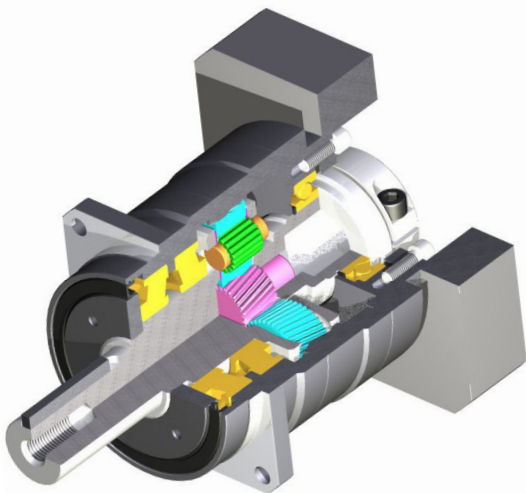
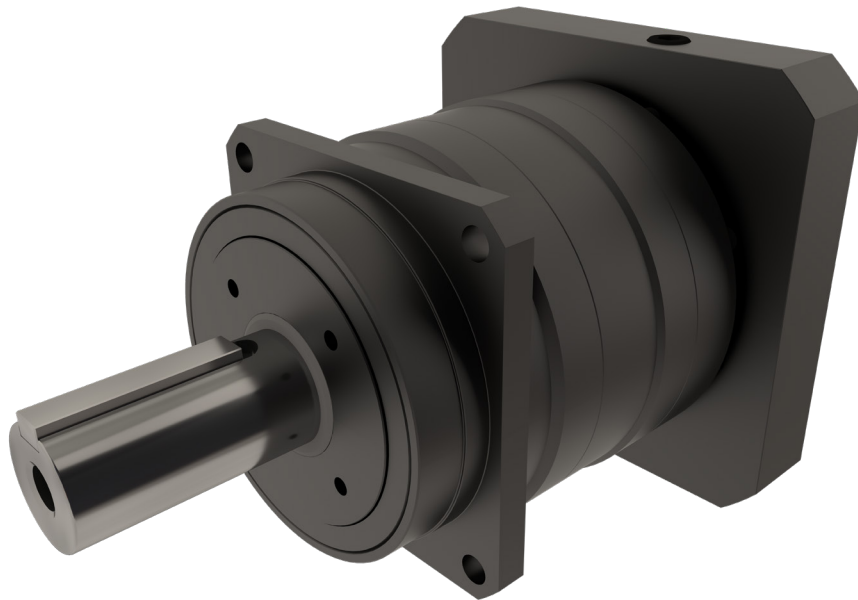

Design Features

- Case hardened and ground gearing for consistent very low backlash, high load capacity offering the highest levels of precision and lowest noise levels.
- Case hardened steel ring gear integral with housing for highest quality and load capacity.
- Output shaft supported by large tapered roller bearings for higher radial load capacity.

Universal Housing

- Mount in any position
- Filled with synthetic grease
- IP 54 rated (IP65 optional)

Performance

- Lifetime up to 20,000 hours
- Backlash ≤ 3 arcminutes
- 5 Year Warranty

* 1 2 3 4 5 6 7 8 9 10 11 12 13 14 15 16 17 18 19 20

P 1 0 0 3 1 5 . L S K S 1 L C G K C K -

1 SERIES **P**

2-4 SIZE OF UNIT

0	6	0
0	7	5
1	0	0
1	4	0

1	8	0
2	1	0
2	4	0

5 REVISION

3

6-8 NOMINAL OVERALL RATIO

Single Stage

3	.	0
4	.	0
5	.	0
6	.	0
7	.	0
8	.	0
9	.	0
1	0	.

Double Stage

1	5	.
1	6	.
2	0	.
2	5	.
2	8	.
3	0	.
3	5	.
4	0	.
4	5	.
5	0	.
6	0	.
7	0	.
8	0	.
9	0	.
1	0	0

9 UNIT VERSION

L Low backlash

10 TYPE OF UNIT

S Unit to fit servomotor

11 OUTPUT SHAFT

N Smooth output shaft (non-standard)

K Keyed output shaft (standard)

20 SPECIAL FEATURES

- No special features

19 MOTOR SHAFT DIAMETER

K See page 20 & 21 for servo motor shaft diameter

18 MOTOR MOUNTING HOLES

C See page 20 & 21 for servo motor bolt hole size

17 MOTOR BOLT CIRCLE

K See page 20 & 21 for servo motor bolt circle diameter

16 MOTOR PILOT

G See page 20 & 21 for servo motor pilot diameter

15 MOTOR FLANGE SQUARE

C See page 20 & 21 for servo motor flange square

14 SHAFT LENGTH

L See page 20 & 21 for servo motor shaft length

13 ASSEMBLY POSITION

1 Single ext. Solid

12 MOTOR / TYPE / SIZE

S Servo motor

We reserve the right to improve or change product design and specifications without notice.

Series P - N Type Motor Mounting Codes

P060 SELECTIONS

COLUMN 14 ENTRY	SHAFT LENGTH RANGE BASED ON MOTOR SHAFT DIAMETER																	
	MOTOR FLANGE SQ.	52 / 60 / 70				65 / 80 / 90				70		100 / 115		80 / 90 / 100				
	MOTOR SHAFT Ø	≤ Ø 8 mm				≤ Ø 14 mm				≤ Ø 19 mm		≤ Ø 19 mm		≤ Ø 19 mm				
	MOTOR SHAFT LENGTH RANGE	MIN	MAX	MIN	MAX	MIN	MAX	MIN	MAX	MIN	MAX	MIN	MAX	MIN	MAX			
COLUMN 14 ENTRY	18	35	20	43	20	38	20	33	24	58								
	C		B		E		F		G									
COLUMN 15 ENTRY	FLANGE SQUARE																	
	52	60	65	70	80	90	100	115										
	G	P	L	A	B	C	D	E										
COLUMN 16 ENTRY	PILOT DIAMETER																	
	22	30	36	38.1	40	50	54	55.563	60	70	73.025	80	95	100	110	114.3	115	
	N	T	P	A	B	C	Q	R	D	E	F	G	H	U	J	K	V	
COLUMN 17 ENTRY	BOLT CIRCLE																	
	43.82	46	63	66.68	70	70.71	75	80	90	95	98.43	98.995	100	115	125.73	130	145	165
	B	V	A	C	D	S	E	F	G	H	J	T	K	L	U	M	N	P
COLUMN 18 ENTRY	BOLT HOLE DIAMETER IN MOTOR FLANGE																	
	3.4 - 4.4	4.5 - 5.2	5.3 - 6.3	6.4 - 8.3	8.4 - 10.3	10.4 - 12.4	#6 - 32	#8 - 32	3/8 - 16	M3	M6	M8						
	J	A	B	C	D	E	K	L	M	P	Q	R						
COLUMN 19 ENTRY	MOTOR SHAFT DIAMETER																	
	Single Reduction	5	6	6.35	7	8	9	9.525	10	11	12	12.7	14	15.875	16	17	19	
		Y	Z	A	7	B	C	D	E	F	G	H	J	K	9	L		
	Double Reduction	5	6	6.35	7	8	9	9.525	10	11	12	12.7	14	15.875	16	17	19	
Y		Z	A	7	B	C	D	E	F	G	H	J	K	8	9	L		

P075 SELECTIONS

COLUMN 14 ENTRY	SHAFT LENGTH RANGE BASED ON MOTOR SHAFT DIAMETER																					
	MOTOR FLANGE SQ.	52 / 60 / 70				65 / 70 / 80 / 90 / 100				115 / 150		80 / 90 / 100 / 115		130 / 150		100 / 115		130		150		
	MOTOR SHAFT Ø	≤ Ø 8 mm				≤ Ø 14 mm				≤ Ø 19 mm		≤ Ø 19 mm		≤ Ø 28 mm		≤ Ø 28 mm		≤ Ø 28 mm		≤ Ø 28 mm		
	MOTOR SHAFT LENGTH RANGE	MIN	MAX	MIN	MAX	MIN	MAX	MIN	MAX	MIN	MAX	MIN	MAX	MIN	MAX	MIN	MAX	MIN	MAX	MIN	MAX	
COLUMN 14 ENTRY	18	35	20	43	20	48	24	58	24	63	24	63	27	65	27	65	27	65	27	80	32	85
	C		H		J		L		M		P		R		S							
COLUMN 15 ENTRY	FLANGE SQUARE																					
	52	60	65	70	80	90	100	115	130	150												
	G	P	L	A	B	C	D	E	J	K												
COLUMN 16 ENTRY	PILOT DIAMETER																					
	22	30	36	38.1	40	50	54	55.563	60	63.5	70	73.025	80	95	100	110	114.3	115	130	180	200	
	N	T	P	A	B	C	Q	R	S	E	F	G	H	U	J	K	V	L	M	W		
COLUMN 17 ENTRY	BOLT CIRCLE																					
	43.82	46	63	66.68	70	70.71	75	80	90	95	98.43	98.995	100	115	125.73	130	145	149.23	165	200	215	
	B	V	A	C	D	S	E	F	G	H	J	T	K	L	U	M	N	W	P	Q	R	
COLUMN 18 ENTRY	BOLT HOLE DIAMETER IN MOTOR FLANGE																					
	3.4 - 4.4	4.5 - 5.2	5.3 - 6.3	6.4 - 8.3	8.4 - 10.3	10.4 - 12.4	12.5 - 15	#6 - 32	#8 - 32	3/8 - 16	M3	M6	M8									
	J	A	B	C	D	E	F	K	L	M	P	Q	R									
COLUMN 19 ENTRY	MOTOR SHAFT DIAMETER																					
	Single Reduction	9	9.525	10	11	12	12.7	14	15.875	16	17	19	19.05	22	22.225	24	26	28				
		C	D	E	F	G	H	J	K	9	L	2	M	3	N	4	P					
	Double Reduction	5	6	6.35	7	8	9	9.525	10	11	12	12.7	14	15.875	16	17	19	19.05				
Y		Z	A	7	B	C	D	E	F	G	H	J	K	9	L	2	M	3	N	4	P	

P100 SELECTIONS

COLUMN 14 ENTRY	SHAFT LENGTH RANGE BASED ON MOTOR SHAFT DIAMETER																						
	MOTOR FLANGE SQ.	65 / 70 / 80 / 90 / 100				115 / 150		80 / 90 / 100 / 115		130 / 150		100 / 115		130		150		180		130 / 150		180	
	MOTOR SHAFT Ø	≤ Ø 14 mm				≤ Ø 19 mm		≤ Ø 19 mm		≤ Ø 28 mm		≤ Ø 28 mm		≤ Ø 28 mm		≤ Ø 28 mm		≤ Ø 38 mm		≤ Ø 38 mm		≤ Ø 38 mm	
	MOTOR SHAFT LENGTH RANGE	MIN	MAX	MIN	MAX	MIN	MAX	MIN	MAX	MIN	MAX	MIN	MAX	MIN	MAX	MIN	MAX	MIN	MAX	MIN	MAX	MIN	MAX
COLUMN 14 ENTRY	20	43	20	48	24	58	24	63	27	65	27	80	32	85	32	85	32	75	37	80	42	115	
	H		J		L		M		P		R		S		T		U		W				
COLUMN 15 ENTRY	FLANGE SQUARE																						
	65	70	80	90	100	115	130	150	180														
	L	A	B	C	D	E	J	K	H														
COLUMN 16 ENTRY	PILOT DIAMETER																						
	36	38.1	40	50	54	55.563	60	63.5	70	73.025	80	95	100	110	114.3	115	130	180	200	215.9	230		
	P	A	B	C	Q	R	S	E	F	G	H	U	J	K	V	L	M	W	X	Y			
COLUMN 17 ENTRY	BOLT CIRCLE																						
	63	66.68	70	70.71	75	80	90	95	98.43	98.995	100	115	125.73	130	145	149.23	165	200	215	235	250	265	
	A	C	D	S	E	F	G	H	J	T	K	L	U	M	N	W	P	Q	R	Z	7	8	
COLUMN 18 ENTRY	BOLT HOLE DIAMETER IN MOTOR FLANGE																						
	4.5 - 5.2	5.3 - 6.3	6.4 - 8.3	8.4 - 10.3	10.4 - 12.4	12.5 - 15	3/8 - 16	1/2 - 13	M6	M8													
	A	B	C	D	E	F	M	N	Q	R													
COLUMN 19 ENTRY	MOTOR SHAFT DIAMETER																						
	Single Reduction	15.875	16	17	19	19.05	22	22.225	24	26	28	28.575	32	35	38								
		8	K	9	L	2	M	3	N	4	P	5	Q	R	S								
	Double Reduction	9	9.525	10	11	12	12.7	14	15.875	16	17	19	19.05	22	22.225								
C		D	E	F	G	H	J	K	9	L	2	M	3	N	4	P	5	Q	R	S			

P140 SELECTIONS

COLUMN 14 ENTRY	SHAFT LENGTH RANGE BASED ON MOTOR SHAFT DIAMETER																								
	MOTOR FLANGE SQ.	80 / 90 / 100 / 115				130 / 150		100 / 115		130		150		180 / 200 / 220		130 / 150		180		200		220		180 / 200 / 220	
	MOTOR SHAFT Ø	≤ Ø 19 mm				≤ Ø 28 mm		≤ Ø 28 mm		≤ Ø 28 mm		≤ Ø 28 mm		≤ Ø 38 mm		≤ Ø 38 mm		≤ Ø 38 mm		≤ Ø 48 mm		≤ Ø 48 mm		≤ Ø 48 mm	
	MOTOR SHAFT LENGTH RANGE	MIN	MAX	MIN	MAX	MIN	MAX	MIN	MAX	MIN	MAX	MIN	MAX	MIN	MAX	MIN	MAX	MIN	MAX	MIN	MAX	MIN	MAX	MIN	MAX
COLUMN 14 ENTRY	24	58	24	63	27	65	27	80	32	85	32	75	37	80	42	115	42	115	42	90	42	95	40	116	
	L		M		P		R		S		T		U		W		X		Y		Z				
COLUMN 15 ENTRY	FLANGE SQUARE																								
	80	90	100	115	130	150	180	200	220																
	B	C	D	E	J	K	H	M	N																
COLUMN 16 ENTRY	PILOT DIAMETER																								
	55.563	60	63.5	70	73.025	80	95	100	110	114.3	115	130	180	200	215.9	230	250								
	R	D	S	E	F	G	H	U	J	K	V	L	M	W	X	Y	Z								
COLUMN 17 ENTRY	BOLT CIRCLE																								
	90	98.43	100	115	125.73	130	145	149.23	165	184.15	200	215	220	235	250	265	300								
	G	J	K	L	U	M	N	W	P	X	Q	R	Y	Z	7	8	9								
COLUMN 18 ENTRY	BOLT HOLE DIAMETER IN MOTOR FLANGE																								
	5.3 - 6.3	6.4 - 8.3	8.4 - 10.3	10.4 - 12.4	12.5 - 15	17 - 20	3/8 - 16	1/2 - 13	M8																
	B	C	D	E	F	G	M	N	R																
COLUMN 19 ENTRY	MOTOR SHAFT DIAMETER																								
	Single Reduction	19.05	22	22.225	24	26	28	28.575	32	35	38	42	48												
		2	M	3	N	4	P	5	Q	R	S	T	V												
	Double Reduction	15.875	16	17	19	19.05	22	22.225	24	26	28	28.575	32												
8		K	9	L	2	M	3	N	4	P	5	Q	R	S	T	V									

P180 SELECTIONS

COLUMN 14 ENTRY	SHAFT LENGTH RANGE BASED ON MOTOR SHAFT DIAMETER																														
	MOTOR FLANGE SQ.	100 / 115			130			150			180 / 200 / 220			130 / 150			180			200			220			250			180 / 200 / 220 / 250 / 280		
	MOTOR SHAFT Ø	≤ Ø 28 mm																													
	MOTOR SHAFT LENGTH RANGE	MIN	MAX	MIN	MAX	MIN	MAX	MIN	MAX	MIN	MAX	MIN	MAX	MIN	MAX	MIN	MAX	MIN	MAX	MIN	MAX	MIN	MAX	MIN	MAX	MIN	MAX				
COLUMN 14 ENTRY	P			R			S			T			U			W			X			Y			Z						
COLUMN 15 ENTRY	FLANGE SQUARE																														
	100	115	130	150	180	200	220	250	280																						
	D	E	J	K	H	M	N	Q	R																						
COLUMN 16 ENTRY	PILOT DIAMETER																														
	55.563	63.5	80	95	110	114.3	130	180	200	215.9	230	250	300																		
	R	S	G	H	J	K	L	M	W	X	Y	Z	7																		
COLUMN 17 ENTRY	BOLT CIRCLE																														
	100	115	125.73	130	145	149.23	165	184.15	200	215	220	235	250	265	300	350															
	K	L	U	M	N	W	P	X	Q	R	Y	Z	7	8	9	2															
COLUMN 18 ENTRY	BOLT HOLE DIAMETER IN MOTOR FLANGE																														
	6.4 - 8.3			8.4 - 10.3			10.4 - 12.4			12.5 - 15			17 - 20			21 - 24			3/8 - 16			1/2 - 13			M8						
	C			D			E			F			G			H			M			N			R						
COLUMN 19 ENTRY	MOTOR SHAFT DIAMETER																														
	Single Reduction	28.575	32	35	38	42	45	48	55	60	65																				
		5	Q	R	S	T	U	V	W	X	6																				
	Double Reduction	19.05	22	22.225	24	26	28	28.575	32	35	38	42	45	48																	
	2	M	3	N	4	P	5	Q	R	S	T	U	V																		

P210 SELECTIONS

COLUMN 14 ENTRY	SHAFT LENGTH RANGE BASED ON MOTOR SHAFT DIAMETER																											
	MOTOR FLANGE SQ.	130 / 150			180			200			220			250			180 / 200 / 220 / 250 / 280			220			250 / 280			320		
	MOTOR SHAFT Ø	≤ Ø 38 mm																										
	MOTOR SHAFT LENGTH RANGE	MIN	MAX	MIN	MAX	MIN	MAX	MIN	MAX	MIN	MAX	MIN	MAX	MIN	MAX	MIN	MAX	MIN	MAX	MIN	MAX	MIN	MAX	MIN	MAX			
COLUMN 14 ENTRY	U			W			X			Y			Z			4			6			8						
COLUMN 15 ENTRY	FLANGE SQUARE																											
	130	150	180	200	220	250	280	320																				
	J	K	H	M	N	Q	R	T																				
COLUMN 16 ENTRY	PILOT DIAMETER																											
	95	110	114.3	130	180	200	215.9	230	250	300																		
	H	J	K	L	M	W	X	Y	Z	7																		
COLUMN 17 ENTRY	BOLT CIRCLE																											
	130	145	165	184.15	200	215	235	250	265	300	350																	
	M	N	P	X	Q	R	Z	7	8	9	2																	
COLUMN 18 ENTRY	BOLT HOLE DIAMETER IN MOTOR FLANGE																											
	8.4 - 10.3			10.4 - 12.4			12.5 - 15			17 - 20			21 - 24			1/2 - 13			M8									
	D			E			F			G			H			N			R									
COLUMN 19 ENTRY	MOTOR SHAFT DIAMETER																											
	Single Reduction	42	45	48	55	60	65																					
		T	U	V	W	X	6																					
	Double Reduction	28.575	32	35	38	42	45	48																				
	5	Q	R	S	T	U	V																					

P240 SELECTIONS

COLUMN 14 ENTRY	SHAFT LENGTH RANGE BASED ON MOTOR SHAFT DIAMETER																				
	MOTOR FLANGE SQ.	180 / 200 / 220 / 250 / 280				220				250 / 280				320							
	MOTOR SHAFT Ø	≤ Ø 48 mm																			
	MOTOR SHAFT LENGTH RANGE	MIN	MAX	MIN	MAX	MIN	MAX	MIN	MAX	MIN	MAX	MIN	MAX								
COLUMN 14 ENTRY	Z				4				6				8								
COLUMN 15 ENTRY	FLANGE SQUARE																				
	180	200	220	250	280	320															
	H	M	N	Q	R	T															
COLUMN 16 ENTRY	PILOT DIAMETER																				
	110	114.3	130	180	200	215.9	230	250	300												
	J	K	L	M	W	X	Y	Z	7												
COLUMN 17 ENTRY	BOLT CIRCLE																				
	130	145	165	184.15	200	215	235	250	265	300	350										
	M	N	P	X	Q	R	Z	7	8	9	2										
COLUMN 18 ENTRY	BOLT HOLE DIAMETER IN MOTOR FLANGE																				
	8.4 - 10.3			10.4 - 12.4			12.5 - 15			17 - 20			21 - 24			1/2 - 13			M8		
	D			E			F			G			H			N			R		
COLUMN 19 ENTRY	MOTOR SHAFT DIAMETER																				
	Single Reduction	55	60	65																	
		W	X	6																	
	Double Reduction	42	45	48																	
	T	U	V																		

Series P - N Type Output Torque Ratings

OUTPUT TORQUE BY GEARBOX SIZE															
RATIOS	UNITS	P-N 060		P-N 075		P-N 100		P-N 140		P-N 180		P-N 210		P-N 240	
		T_{2N}	T_{2ACC}	T_{2N}	T_{2ACC}	T_{2N}	T_{2ACC}	T_{2N}	T_{2ACC}	T_{2N}	T_{2ACC}	T_{2N}	T_{2ACC}	T_{2N}	T_{2ACC}
3	Nm	18	35	50	80	120	225	240	470	500	970	1000	1600	1600	2500
4		27	50	75	125	120	330	240	700	750	1400	1500	2300	2400	3700
5		27	50	75	125	180	330	360	700	750	1400	1500	2300	2400	3700
6		27	50	75	125	180	330	360	700	750	1400	1500	2300	2400	3700
7		27	50	75	125	180	330	360	700	750	1400	1500	2300	2400	3700
8		27	50	75	125	180	330	360	700	750	1400	1500	2200	2400	3600
9		18	35	50	80	120	225	240	470	500	970	1000	1900	1600	3000
10		18	35	50	80	120	225	240	470	500	970	1000	1600	1600	2600
15		18	35	50	80	120	225	240	470	500	970	1000	1600	1600	2500
16		27	50	75	125	180	330	360	700	750	1400	1500	2300	2400	3700
20		27	50	75	125	180	330	360	700	750	1400	1500	2300	2400	3700
25		27	50	75	125	180	330	360	700	750	1400	1500	2300	2400	3700
28		27	50	75	125	180	330	360	700	750	1400	1500	2300	2400	3700
30		18	35	50	80	120	225	240	470	500	970	1000	1600	1600	2500
35		27	50	75	125	180	330	360	700	750	1400	1500	2300	2400	3700
40		27	50	75	125	180	330	360	700	750	1400	1500	2300	2400	3700
45		18	35	50	80	120	225	240	470	500	970	1000	1300	1600	2100
50		27	50	75	125	180	330	360	700	750	1400	1500	2300	2400	3700
60		27	50	75	125	180	330	360	700	750	1400	1500	2300	2400	3700
70		27	50	75	125	180	330	360	700	750	1400	1500	2300	2400	3700
80	27	50	75	125	180	330	360	700	750	1400	1500	1800	2400	2700	
90	18	35	50	80	120	225	240	470	500	970	1000	1300	1600	2100	
100	18	35	50	80	120	225	240	470	500	970	1000	1200	1600	1800	

T_{2N} - At nominal input speed, service life is 20,000 hours

T_{2ACC} - The maximum torque during acceleration and deceleration

ATTRIBUTE	UNITS	GEAR STAGES	SIZE						
			P-N 060	P-N 075	P-N 100	P-N 140	P-N 180	P-N 210	P-N 240
Emergency Stop Torque ¹	Nm	1 & 2	$2 \times T_{2ACC}$						
Degree of Protection ²	—		IP54 (IP65 OPTIONAL)						
Nominal Input Speed ³	rpm		3000	3000	3000	2000	1500	1000	1000
Maximum Input Speed ⁴	rpm		6000	6000	6000	4000	3000	2000	2000
Permitted Housing Temperature	°C	—	90						
Efficiency ⁵	%	1	95	95	95	95	95	97	97
		2	90	90	90	90	90	92	92
Weight ⁶	kg	1	1.6	3.4	8.1	17	39	59	85
		2	1.8	3.8	8.8	19	39	60	89
Maximum Torsional Backlash	arc-min	1	≤ 3	≤ 3	≤ 3	≤ 3	≤ 3	≤ 3	≤ 3
		2	≤ 3	≤ 3	≤ 3	≤ 3	≤ 3	≤ 3	≤ 3
Torsional Rigidity ⁷	Nm/ arc-min	1	3	10	31	60	175	400	550
		2	3	10	31	60	175	400	550
Noise Level ⁸	dB	1	≤ 66	≤ 67	≤ 71	≤ 67	≤ 67	≤ 61	≤ 62
		2	≤ 66	≤ 67	≤ 71	≤ 67	≤ 67	≤ 61	≤ 62
No Load Running Torque ⁹	Nm	1	0.15	0.35	1.3	1.63	2.68	2.92	5.96
		2	0.04	0.06	0.42	0.56	1.39	1.14	1.28

1 The maximum torque allowed under a stress situation (Permitted 1,000 times during service life)

2 IP65 (wash-down) is available as an option. Contact Cone Drive for more details

3 The average input speed

4 The maximum intermittent input speed

5 The efficiency at the nominal output torque rating

6 The weight may vary slightly between models

7 This does not include backlash

8 Contact Cone Drive for the testing conditions and environment

9 Torque at no load applied to the input shaft at nominal input speed

Series P - N Type Radial & Axial Shaft Load Ratings

PERMITTED RADIAL LOADS

RATIO	UNITS	GEAR STAGES	SIZE								
			Permitted Radial Load ¹								
			P-N 060	P-N 075	P-N 100	P-N 140	P-N 180	P-N 210	P-N 240		
3	N	1	1700	2300	3400	6700	12000	17000	21000		
4			1900	2500	3700	7400	13000	18000	22000		
5			2000	2700	4000	7900	14000	20000	24000		
6			2100	2800	4200	8300	15000	21000	25000		
7			2200	3000	4400	8700	16000	22000	26000		
8			2300	3100	4600	9100	17000	23000	28000		
9			2400	3200	4800	9400	17000	24000	29000		
10			2400	3300	4900	9700	18000	24000	29000		
15			2	2	2800	3700	5600	10000	19000	24000	30000
16					2800	3800	5700	10000	19000	24000	30000
20		3000			4000	6100	10000	19000	24000	30000	
25		3000			4300	6500	10000	19000	24000	30000	
28		3000			4300	6700	10000	19000	24000	30000	
30		3000			4300	6900	10000	19000	24000	30000	
35		3000			4300	7000	10000	19000	24000	30000	
40		3000			4300	7000	10000	19000	24000	30000	
45		3000			4300	7000	10000	19000	24000	30000	
50		3000			4300	7000	10000	19000	24000	30000	
60		3000	4300	7000	10000	19000	24000	30000			
70		3000	4300	7000	10000	19000	24000	30000			
80	3000	4300	7000	10000	19000	24000	30000				
90	3000	4300	7000	10000	19000	24000	30000				
100	3000	4300	7000	10000	19000	24000	30000				

1 At this load and nominal input speed, service life will be 20,000 hours.
(The radial load applied to the output side shaft center)

PERMITTED AXIAL LOADS

RATIO	UNITS	GEAR STAGES	SIZE								
			Permitted Axial Load ²								
			P-N 060	P-N 075	P-N 100	P-N 140	P-N 180	P-N 210	P-N 240		
3	N	1	2300	3400	4800	9000	16000	22000	27000		
4			2500	3700	5200	9000	17000	22000	27000		
5			2700	3900	5600	9000	17000	22000	27000		
6			2700	3900	5900	9000	17000	22000	27000		
7			2700	3900	6100	9000	17000	22000	27000		
8			2700	3900	6300	9000	17000	22000	27000		
9			2700	3900	6300	9000	17000	22000	27000		
10			2700	3900	6300	9000	17000	22000	27000		
15			2	2	2700	3900	6300	9000	17000	22000	27000
16					2700	3900	6300	9000	17000	22000	27000
20		2700			3900	6300	9000	17000	22000	27000	
25		2700			3900	6300	9000	17000	22000	27000	
28		2700			3900	6300	9000	17000	22000	27000	
30		2700			3900	6300	9000	17000	22000	27000	
35		2700			3900	6300	9000	17000	22000	27000	
40		2700			3900	6300	9000	17000	22000	27000	
45		2700			3900	6300	9000	17000	22000	27000	
50		2700			3900	6300	9000	17000	22000	27000	
60		2700	3900	6300	9000	17000	22000	27000			
70		2700	3900	6300	9000	17000	22000	27000			
80	2700	3900	6300	9000	17000	22000	27000				
90	2700	3900	6300	9000	17000	22000	27000				
100	2700	3900	6300	9000	17000	22000	27000				

2 At this load and nominal input speed, service life will be 20,000 hours.
(The axial load applied to the output side bearing)

MAXIMUM RADIAL LOADS

RATIO	UNITS	GEAR STAGES	SIZE								
			Maximum Radial Load ¹								
			P-N 060	P-N 075	P-N 100	P-N 140	P-N 180	P-N 210	P-N 240		
3	N	1	3000	4300	7000	10000	19000	24000	30000		
4			3000	4300	7000	10000	19000	24000	30000		
5			3000	4300	7000	10000	19000	24000	30000		
6			3000	4300	7000	10000	19000	24000	30000		
7			3000	4300	7000	10000	19000	24000	30000		
8			3000	4300	7000	10000	19000	24000	30000		
9			3000	4300	7000	10000	19000	24000	30000		
10			3000	4300	7000	10000	19000	24000	30000		
15			2	2	3000	4300	7000	10000	19000	24000	30000
16					3000	4300	7000	10000	19000	24000	30000
20		3000			4300	7000	10000	19000	24000	30000	
25		3000			4300	7000	10000	19000	24000	30000	
28		3000			4300	7000	10000	19000	24000	30000	
30		3000			4300	7000	10000	19000	24000	30000	
35		3000			4300	7000	10000	19000	24000	30000	
40		3000			4300	7000	10000	19000	24000	30000	
45		3000			4300	7000	10000	19000	24000	30000	
50		3000			4300	7000	10000	19000	24000	30000	
60		3000	4300	7000	10000	19000	24000	30000			
70		3000	4300	7000	10000	19000	24000	30000			
80	3000	4300	7000	10000	19000	24000	30000				
90	3000	4300	7000	10000	19000	24000	30000				
100	3000	4300	7000	10000	19000	24000	30000				

1 The maximum radial load that the gearbox can accept at the center of the output shaft

MAXIMUM AXIAL LOADS

RATIO	UNITS	GEAR STAGES	SIZE								
			Maximum Axial Load ²								
			P-N 060	P-N 075	P-N 100	P-N 140	P-N 180	P-N 210	P-N 240		
3	N	1	2700	3900	6300	9000	17000	22000	27000		
4			2700	3900	6300	9000	17000	22000	27000		
5			2700	3900	6300	9000	17000	22000	27000		
6			2700	3900	6300	9000	17000	22000	27000		
7			2700	3900	6300	9000	17000	22000	27000		
8			2700	3900	6300	9000	17000	22000	27000		
9			2700	3900	6300	9000	17000	22000	27000		
10			2700	3900	6300	9000	17000	22000	27000		
15			2	2	2700	3900	6300	9000	17000	22000	27000
16					2700	3900	6300	9000	17000	22000	27000
20		2700			3900	6300	9000	17000	22000	27000	
25		2700			3900	6300	9000	17000	22000	27000	
28		2700			3900	6300	9000	17000	22000	27000	
30		2700			3900	6300	9000	17000	22000	27000	
35		2700			3900	6300	9000	17000	22000	27000	
40		2700			3900	6300	9000	17000	22000	27000	
45		2700			3900	6300	9000	17000	22000	27000	
50		2700			3900	6300	9000	17000	22000	27000	
60		2700	3900	6300	9000	17000	22000	27000			
70		2700	3900	6300	9000	17000	22000	27000			
80	2700	3900	6300	9000	17000	22000	27000				
90	2700	3900	6300	9000	17000	22000	27000				
100	2700	3900	6300	9000	17000	22000	27000				

2 The maximum axial load that the gearbox can accept

RATIO	UNITS	SIZE											
		P-N 060			P-N 075				P-N 100				
Motor Shaft Diameter		≤Ø 8	≤Ø 14	≤Ø 19	≤Ø 8	≤Ø 14	≤Ø 19	≤Ø 28	≤Ø 8	≤Ø 14	≤Ø 19	≤Ø 28	≤Ø 38
3	kgcm ²	0.15	0.26	0.54	-	0.68	1.1	2.9	-	-	3.1	5	12
4		0.1	0.21	0.49	-	0.48	0.87	2.6	-	-	1.9	3.7	10
5		0.08	0.19	0.47	-	0.39	0.79	2.6	-	-	1.4	3.1	9.5
6		0.07	0.18	0.46	-	0.34	0.74	2.5	-	-	1.1	2.8	9.2
7		0.064	0.18	0.45	-	0.32	0.72	2.5	-	-	1	2.7	9.1
8		0.06	0.17	0.45	-	0.31	0.71	2.5	-	-	0.91	2.6	8.9
9		0.058	0.17	0.45	-	0.3	0.7	2.5	-	-	0.85	2.6	8.9
10		0.056	0.17	0.44	-	0.29	0.69	2.4	-	-	0.82	2.5	8.8
15		0.064	0.18	0.45	0.2	0.36	0.75	2.5	-	0.76	1.1	2.9	9.2
16		0.07	0.18	0.46	0.25	0.41	0.79	2.5	-	0.97	1.4	3.1	9.4
20		0.062	0.17	0.45	0.19	0.35	0.74	2.5	-	0.72	1.1	2.8	9.1
25		0.062	0.17	0.45	0.19	0.35	0.73	2.5	-	0.7	1.1	2.8	9.1
28		0.068	0.18	0.46	0.24	0.4	0.78	2.5	-	0.92	1.3	3	9.3
30		0.052	0.16	0.44	0.12	0.28	0.67	2.4	-	0.38	0.78	2.5	8.8
35		0.061	0.17	0.45	0.18	0.34	0.73	2.5	-	0.68	1.1	2.8	9.1
40		0.051	0.16	0.44	0.11	0.27	0.67	2.4	-	0.37	0.77	2.5	8.8
45		0.061	0.17	0.45	0.18	0.34	0.73	2.5	-	0.68	1.1	2.8	9.1
50		0.051	0.16	0.44	0.11	0.27	0.67	2.4	0.19	0.36	0.76	2.5	8.8
60		0.051	0.16	0.44	0.11	0.27	0.67	2.4	0.19	0.36	0.76	2.5	8.8
70		0.051	0.16	0.44	0.11	0.27	0.67	2.4	0.19	0.36	0.76	2.5	8.8
80	0.051	0.16	0.44	0.11	0.27	0.67	2.4	0.19	0.36	0.76	2.5	8.8	
90	0.051	0.16	0.44	0.11	0.27	0.67	2.4	0.19	0.36	0.76	2.5	8.8	
100	0.051	0.16	0.44	0.11	0.27	0.67	2.4	0.19	0.36	0.76	2.5	8.8	

RATIO	UNITS	SIZE																
		P-N 140					P-N 180					P-N 210				P-N 240		
Motor Shaft Diameter		≤Ø 14	≤Ø 19	≤Ø 28	≤Ø 38	≤Ø 48	≤Ø 19	≤Ø 28	≤Ø 38	≤Ø 48	≤Ø 65	≤Ø 28	≤Ø 38	≤Ø 48	≤Ø 65	≤Ø 38	≤Ø 48	≤Ø 65
3	kgcm ²	-	-	12	18	35	-	-	41	55	110	-	-	110	160	-	-	230
4		-	-	7.2	14	29	-	-	25	40	84	-	-	55	99	-	-	130
5		-	-	5.2	12	27	-	-	18	33	78	-	-	42	86	-	-	110
6		-	-	4.3	11	26	-	-	15	30	74	-	-	36	80	-	-	92
7		-	-	3.8	10	25	-	-	13	29	73	-	-	33	77	-	-	86
8		-	-	3.5	9.9	25	-	-	12	27	71	-	-	31	74	-	-	81
9		-	-	3.3	9.7	25	-	-	12	27	71	-	-	29	73	-	-	78
10		-	-	3.2	9.6	25	-	-	11	26	70	-	-	28	72	-	-	77
15		-	2.6	4.4	11	26	-	8.7	15	30	34	-	20	34	-	-	47	-
16		-	3.5	5.3	12	27	-	11	18	32	39	-	24	39	-	-	55	-
20		-	2.4	4.2	10	25	-	8.1	14	29	33	-	19	33	-	-	45	-
25		-	2.4	4.1	10	25	-	7.8	14	29	33	-	18	33	-	-	44	-
28		-	3.3	5.1	11	26	-	11	17	32	38	-	23	38	-	-	52	-
30		-	1.1	2.9	9.2	24	-	4	10	25	26	-	12	26	-	-	32	-
35		-	2.3	4.1	10	25	-	7.6	14	29	32	-	18	32	-	-	43	-
40		-	1.1	2.8	9.1	24	-	3.9	10	25	26	-	12	26	-	-	31	-
45		-	2.3	4	10	25	-	7.6	14	29	32	-	18	32	-	-	43	-
50		0.65	1.1	2.8	9.1	24	1.9	3.8	10	25	26	4.7	12	26	-	14	31	-
60		0.64	1.1	2.8	9.1	24	1.9	3.8	10	25	26	4.7	11	26	-	13	31	-
70		0.64	1.1	2.8	9.1	24	1.8	3.8	10	25	26	4.6	11	26	-	13	31	-
80	0.63	1.1	2.8	9.1	24	1.8	3.7	10	25	26	4.6	11	26	-	13	31	-	
90	0.63	1.1	2.8	9.1	24	1.8	3.7	10	25	26	4.6	11	26	-	13	31	-	
100	0.63	1.1	2.8	9.1	24	1.8	3.7	10	25	26	4.6	11	26	-	13	31	-	

Series P - N Type Dimensions

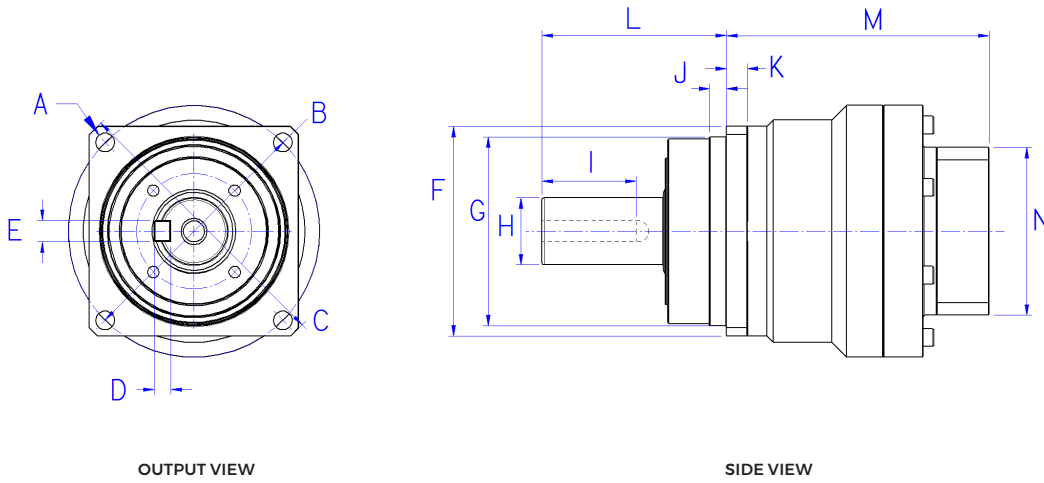

MODEL	UNITS	GEAR STAGES	INPUT BORE SIZE	M	N	A	B	C	D	E	F (g6)	G (g6)	H	I	J	K	L
				BODY LENGTH ¹	INPUT FLANGE SQUARE	MOUNTING HOLE	BOLT CIRCLE	FLANGE DIA-METER	KEY HEIGHT	KEY WIDTH	OUTPUT FLANGE SQUARE	PILOT DIAMETER	SHAFT DIAMETER	KEY LENGTH	PILOT DEPTH	FLANGE THICKNESS	OUTPUT SHAFT LENGTH FROM FLANGE
P-N 060		1	≤ Ø 8	84	52	5.5	68	80	5	5	60	60	16	22	5	6	48
			≤ Ø 14	87	65												
		≤ Ø 19	102	80													
		≤ Ø 8	103	52													
P-N 075		1	≤ Ø 8	108	65	6.6	85	98	6	6	75	70	22	28	6	7	56
			≤ Ø 14	108	65												
		≤ Ø 19	123	80													
		≤ Ø 8	103	52													
P-N 100		1	≤ Ø 14	108.5	65	9	120	136	8	10	100	90	32	45	8	10	88
			≤ Ø 19	118.5	80												
		≤ Ø 28	135.5	130													
		≤ Ø 8	125.5	52													
P-N 140		1	≤ Ø 14	130.5	65	11	165	185	8	12	140	130	40	65	10	12	112
			≤ Ø 19	140.5	80												
		≤ Ø 28	170	130													
		≤ Ø 8	125.5	52													
P-N 180		1	≤ Ø 14	143	65	13.5	215	240	10	16	180	160	55	65	12	15	112
			≤ Ø 19	153	80												
		≤ Ø 28	170	130													
		≤ Ø 8	125.5	52													
P-N 210		1	≤ Ø 14	143	65	17	250	290	12	20	210	180	75	85	15	17	143
			≤ Ø 19	153	80												
		≤ Ø 28	170	130													
		≤ Ø 8	125.5	52													
P-N 240		1	≤ Ø 19	179.5	80	17	290	325	14	22	240	200	85	105	20	20	170
		2	≤ Ø 28	196.5	130												
			≤ Ø 38	211.5	180												

¹ Length will vary depending on motor

ACCUDRIVE SERIES P - S TYPE

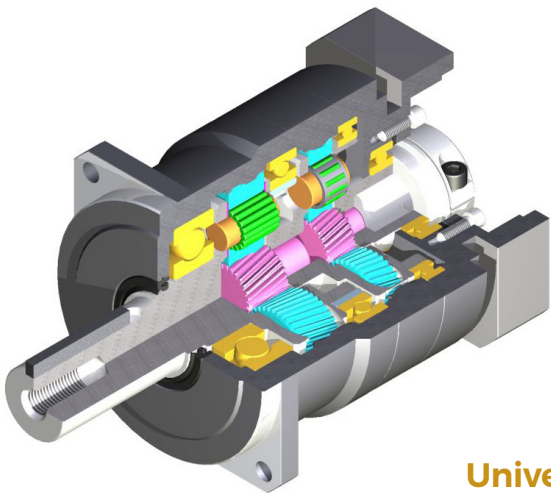
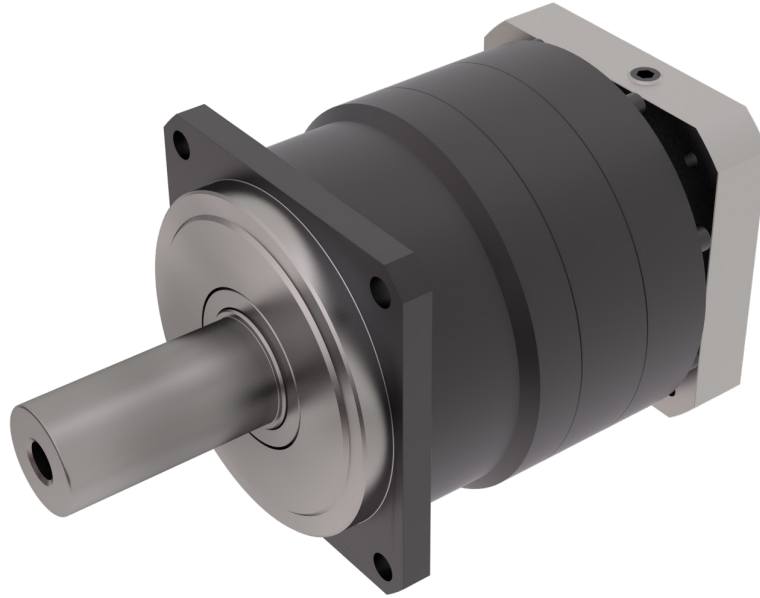

Design Features

- Case hardened and ground gearing for consistent very low backlash, high load capacity offering the highest levels of precision and lowest noise levels.
- Case hardened steel ring gear integral with housing for highest quality and load capacity.
- Output shaft bearing support spread on both sides of the planet gears for higher radial load capacity.

Universal Housing

- Mount in any position
- Filled with synthetic grease
- IP55 rated (*IP65 option available*)

Performance

- Lifetime up to 20,000 hours
- Backlash ≤ 3 arcminutes
- 5 Year Warranty

Series P - S Type Unit Designation

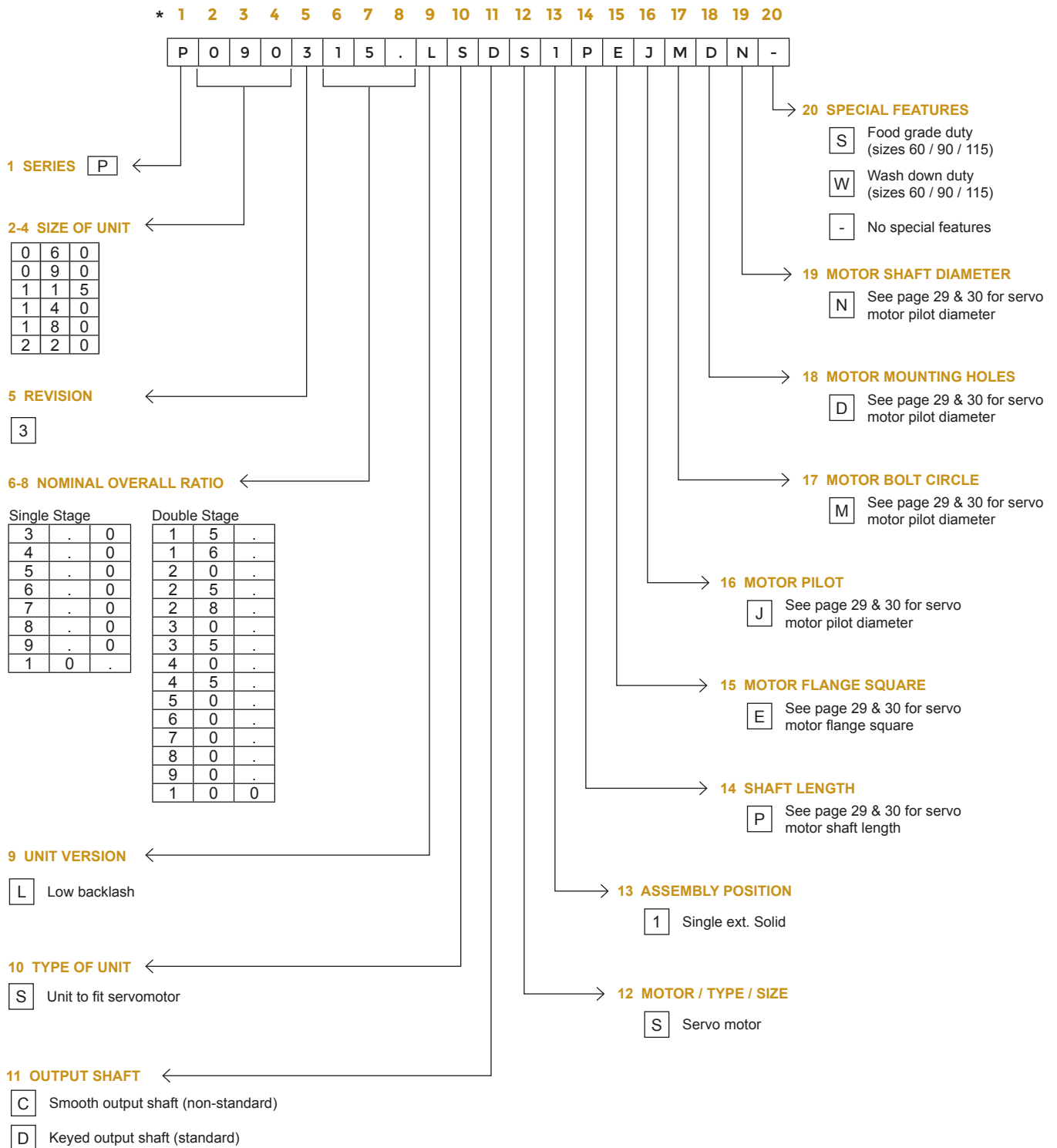

Wash down duty includes:

IP65 Ratings / Stainless output shaft and fasteners / Sealed bearing at the input / 2-part epoxy sealant

Food grade duty includes:

IP65 Ratings / Stainless output shaft and fasteners / Sealed bearing at the input / 2-part epoxy sealant / White epoxy paint

Wash down and food grade are standard options for sizes 60 / 90 / 115 and as a special for sizes 140 / 180 / 220.

We reserve the right to improve or change product design and specifications without notice.

Series P - S Type Motor Mounting Codes

P060 SELECTIONS

COLUMN 14 ENTRY	SHAFT LENGTH RANGE BASED ON MOTOR SHAFT DIAMETER														
	MOTOR FLANGE SQ.	52 / 60 / 70				65 / 80 / 90				70		100 / 115		80 / 90 / 100	
	MOTOR SHAFT Ø	≤ Ø 8 mm				≤ Ø 14 mm				≤ Ø 19 mm		≤ Ø 19 mm		≤ Ø 19 mm	
	MOTOR SHAFT LENGTH RANGE	MIN	MAX	MIN	MAX	MIN	MAX	MIN	MAX	MIN	MAX	MIN	MAX	MIN	MAX
COLUMN 14 ENTRY	18	35	20	43	20	38	20	33	24	58					
COLUMN 14 ENTRY	C		B		E		F		G						

COLUMN 15 ENTRY	FLANGE SQUARE							
	52	60	65	70	80	90	100	115
COLUMN 15 ENTRY	G	P	L	A	B	C	D	E

COLUMN 16 ENTRY	PILOT DIAMETER																
	22	30	36	38.1	40	50	54	55.563	60	70	73.025	80	95	100	110	114.3	115
COLUMN 16 ENTRY	N	T	P	A	B	C	Q	R	D	E	F	G	H	U	J	K	V

COLUMN 17 ENTRY	BOLT CIRCLE																	
	43.82	46	63	66.68	70	70.71	75	80	90	95	98.43	98.995	100	115	125.73	130	145	165
COLUMN 17 ENTRY	B	V	A	C	D	S	E	F	G	H	J	T	K	L	U	M	N	P

COLUMN 18 ENTRY	BOLT HOLE DIAMETER IN MOTOR FLANGE											
	3.4 - 4.4	4.5 - 5.2	5.3 - 6.3	6.4 - 8.3	8.4 - 10.3	10.4 - 12.4	#6 - 32	#8 - 32	3/8 - 16	M3	M6	M8
COLUMN 18 ENTRY	J	A	B	C	D	E	K	L	M	P	Q	R

COLUMN 19 ENTRY	MOTOR SHAFT DIAMETER																	
	Single Reduction	5	6	6.35	7	8	9	9.525	10	11	12	12.7	14	15.875	16	17	19	
		Y	Z	A	7	B	C	D	E	F	G	H	J	8	K	9	L	
	Double Reduction	5	6	6.35	7	8	9	9.525	10	11	12	12.7	14	15.875	16	17	19	
Y	Z	A	7	B	C	D	E	F	G	H	J	8	K	9	L			

P090 SELECTIONS

COLUMN 14 ENTRY	SHAFT LENGTH RANGE BASED ON MOTOR SHAFT DIAMETER																						
	MOTOR FLANGE SQ.	52 / 60 / 70				65 / 70 / 80 / 90 / 100				115 / 150				80 / 90 / 100 / 115		130 / 150		100 / 115		130		150	
	MOTOR SHAFT Ø	≤ Ø 8 mm				≤ Ø 14 mm				≤ Ø 19 mm				≤ Ø 28 mm		≤ Ø 28 mm		≤ Ø 28 mm		≤ Ø 28 mm		≤ Ø 28 mm	
	MOTOR SHAFT LENGTH RANGE	MIN	MAX	MIN	MAX	MIN	MAX	MIN	MAX	MIN	MAX	MIN	MAX	MIN	MAX	MIN	MAX	MIN	MAX	MIN	MAX	MIN	MAX
COLUMN 14 ENTRY	18	35	20	43	20	48	24	58	24	63	27	65	27	80	32	85	32	85	32	85	32	85	
COLUMN 14 ENTRY	C		H		J		L		M		P		R		S								

COLUMN 15 ENTRY	FLANGE SQUARE									
	52	60	65	70	80	90	100	115	130	150
COLUMN 15 ENTRY	G	P	L	A	B	C	D	E	J	K

COLUMN 16 ENTRY	PILOT DIAMETER																				
	22	30	36	38.1	40	50	54	55.563	60	63.5	70	73.025	80	95	100	110	114.3	115	130	180	200
COLUMN 16 ENTRY	N	T	P	A	B	C	Q	R	D	S	E	F	G	H	U	J	K	V	L	M	W

COLUMN 17 ENTRY	BOLT CIRCLE																				
	43.82	46	63	66.68	70	70.71	75	80	90	95	98.43	98.995	100	115	125.73	130	145	149.23	165	200	215
COLUMN 17 ENTRY	B	V	A	C	D	S	E	F	G	H	J	T	K	L	U	M	N	W	P	Q	R

COLUMN 18 ENTRY	BOLT HOLE DIAMETER IN MOTOR FLANGE												
	3.4 - 4.4	4.5 - 5.2	5.3 - 6.3	6.4 - 8.3	8.4 - 10.3	10.4 - 12.4	12.5 - 15	#6 - 32	#8 - 32	3/8 - 16	M3	M6	M8
COLUMN 18 ENTRY	J	A	B	C	D	E	F	K	L	M	P	Q	R

COLUMN 19 ENTRY	MOTOR SHAFT DIAMETER																							
	Single Reduction	9	9.525	10	11	12	12.7	14	15.875	16	17	19	19.05	22	22.225	24	26	28						
		C	D	E	F	G	H	J	8	K	9	L	2	M	3	N	4	P						
	Double Reduction	5	6	6.35	7	8	9	9.525	10	11	12	12.7	14	15.875	16	17	19	19.05	22	22.225	24	26	28	
Y	Z	A	7	B	C	D	E	F	G	H	J	8	K	9	L	2	M	3	N	4	P			

P115 SELECTIONS

COLUMN 14 ENTRY	SHAFT LENGTH RANGE BASED ON MOTOR SHAFT DIAMETER																										
	MOTOR FLANGE SQ.	65 / 70 / 80 / 90 / 100				115 / 150				80 / 90 / 100 / 115				130 / 150		100 / 115		130		150		180		130 / 150		180	
	MOTOR SHAFT Ø	≤ Ø 14 mm				≤ Ø 19 mm				≤ Ø 19 mm				≤ Ø 28 mm		≤ Ø 28 mm		≤ Ø 28 mm		≤ Ø 28 mm		≤ Ø 38 mm		≤ Ø 38 mm		≤ Ø 38 mm	
	MOTOR SHAFT LENGTH RANGE	MIN	MAX	MIN	MAX	MIN	MAX	MIN	MAX	MIN	MAX	MIN	MAX	MIN	MAX	MIN	MAX	MIN	MAX	MIN	MAX	MIN	MAX	MIN	MAX	MIN	MAX
COLUMN 14 ENTRY	20	43	20	48	24	58	24	63	27	65	27	80	32	85	32	85	32	85	32	85	37	75	37	80	42	115	
COLUMN 14 ENTRY	H		J		L		M		P		R		S		T		U		W								

COLUMN 15 ENTRY	FLANGE SQUARE								
	65	70	80	90	100	115	130	150	180
COLUMN 15 ENTRY	L	A	B	C	D	E	J	K	H

COLUMN 16 ENTRY	PILOT DIAMETER																				
	36	38.1	40	50	54	55.563	60	63.5	70	73.025	80	95	100	110	114.3	115	130	180	200	215.9	230
COLUMN 16 ENTRY	P	A	B	C	Q	R	D	S	E	F	G	H	U	J	K	V	L	M	W	X	Y

COLUMN 17 ENTRY	BOLT CIRCLE																					
	63	66.68	70	70.71	75	80	90	95	98.43	98.995	100	115	125.73	130	145	149.23	165	200	215	235	250	265
COLUMN 17 ENTRY	A	C	D	S	E	F	G	H	J	T	K	L	U	M	N	W	P	Q	R	Z	7	8

COLUMN 18 ENTRY	BOLT HOLE DIAMETER IN MOTOR FLANGE											
	4.5 - 5.2	5.3 - 6.3	6.4 - 8.3	8.4 - 10.3	10.4 - 12.4	12.5 - 15	3/8 - 16	1/2 - 13	M6	M8		
COLUMN 18 ENTRY	A	B	C	D	E	F	M	N	Q	R		

COLUMN 19 ENTRY	MOTOR SHAFT DIAMETER																							
	Single Reduction	15.875	16	17	19	19.05	22	22.225	24	26	28	28.575	32	35	38									
		8	K	9	L	2	M	3	N	4	P	5	Q	R	S									
	Double Reduction	9	9.525	10	11	12	12.7	14	15.875	16	17	19	19.05	22	22.225	24	26	28	28	28.575	32	35	38	
C	D	E	F	G	H	J	8	K	9	L	2	M	3	N	4	P	5	Q	R	S				

P140 SELECTIONS

COLUMN 14 ENTRY	SHAFT LENGTH RANGE BASED ON MOTOR SHAFT DIAMETER																												
	MOTOR FLANGE SQ.	80 / 90 / 100 / 115				130 / 150				100 / 115				130		150		180 / 200 / 220		130 / 150		180		200		220		180 / 200 / 220	
	MOTOR SHAFT Ø	≤ Ø 19 mm				≤ Ø 28 mm				≤ Ø 28 mm				≤ Ø 38 mm		≤ Ø 38 mm		≤ Ø 38 mm		≤ Ø 38 mm		≤ Ø 48 mm		≤ Ø 48 mm		≤ Ø 48 mm			
	MOTOR SHAFT LENGTH RANGE	MIN	MAX	MIN	MAX	MIN	MAX	MIN	MAX	MIN	MAX	MIN	MAX	MIN	MAX	MIN	MAX	MIN	MAX	MIN	MAX	MIN	MAX	MIN	MAX	MIN	MAX		
COLUMN 14 ENTRY	24	58	24	63	27	65	27	80	32	85	32	75	37	80	42	115	42	90	42	95	40	116							
COLUMN 14 ENTRY	L		M		P		R		S		T		U		W		X		Y		Z								

COLUMN 15 ENTRY	FLANGE SQUARE								
	80	90	100	115	130	150	180	200	220
COLUMN 15 ENTRY	B	C	D	E	J	K	H	M	N

COLUMN 16 ENTRY	PILOT DIAMETER																
	55.563	60	63.5	70	73.025	80	95	100	110	114.3	115	130	180	200	215.9	230	250
COLUMN 16 ENTRY	R	D	S	E	F	G	H	U	J	K	V	L	M	W	X	Y	Z

COLUMN 17 ENTRY	BOLT CIRCLE																	
	90	98.43	100	115	125.73	130	145	149.23	165	184.15	200	215	220	235	250	265	300	
COLUMN 17 ENTRY	G	J	K	L	U	M	N	W	P	X	Q	R	Y	Z	7	8	9	

COLUMN 18 ENTRY	BOLT HOLE DIAMETER IN MOTOR FLANGE									
	5.3 - 6.3	6.4 - 8.3	8.4 - 10.3	10.4 - 12.4	12.5 - 15	17 - 20	3/8 - 16	1/2 - 13	M8	
COLUMN 18 ENTRY	B	C	D	E	F	G	M	N	R	

COLUMN 19 ENTRY	MOTOR SHAFT DIAMETER															
	Single Reduction	19.05	22	22.225	24	26	28	28.575	32	35	38	42	48			
		2	M	3	N	4	P	5	Q	R	S	T	V			
	Double Reduction	15.875	16	17	19	19.05	22	22.225	24	26	28	28.575	32	35	38	42
8	K	9	L	2	M	3	N	4	P	5	Q	R	S	T	V	

Series P - S Type Motor Mounting Codes

P180 SELECTIONS

COLUMN 14 ENTRY	SHAFT LENGTH RANGE BASED ON MOTOR SHAFT DIAMETER																					
	MOTOR FLANGE SQ.	100 / 115		130		150		180 / 200 / 220		130 / 150		180		200		220		250		180 / 200 / 220 / 250 / 280		
	MOTOR SHAFT Ø	≤ Ø 28 mm																				
	MOTOR SHAFT LENGTH RANGE	MIN	MAX	MIN	MAX	MIN	MAX	MIN	MAX	MIN	MAX	MIN	MAX	MIN	MAX	MIN	MAX	MIN	MAX	MIN	MAX	
COLUMN 14 ENTRY		P	65	27	80	32	85	32	75	37	80	42	115	42	90	42	95	42	80	40	116	
MOTOR FLANGE SQ.	220		250 / 280																			
MOTOR SHAFT Ø	≤ Ø 65 mm																					
MOTOR SHAFT LENGTH RANGE	MIN	MAX	MIN	MAX																		
COLUMN 14 ENTRY	4			6																		
FLANGE SQUARE																						
COLUMN 15 ENTRY	100	115	130	150	180	200	220	250	280													
	D	E	J	K	H	M	N	Q	R													
PILOT DIAMETER																						
COLUMN 16 ENTRY	55.563	63.5	80	95	110	114.3	130	180	200	215.9	230	250	300									
	R	S	G	H	J	K	L	M	W	X	Y	Z	7									
BOLT CIRCLE																						
COLUMN 17 ENTRY	100	115	125.73	130	145	149.23	165	184.15	200	215	220	235	250	265	300	350						
	K	L	U	M	N	W	P	X	Q	R	Y	Z	7	8	9	2						
MOTOR SHAFT DIAMETER																						
COLUMN 19 ENTRY	Single Reduction	28.575	32	35	38	42	45	48	55	60	65											
		5	Q	R	S	T	U	V	W	X	6											
Double Reduction	19.05	22	22.225	24	26	28	28.575	32	35	38	42	45	48									
	2	M	3	N	4	P	5	Q	R	S	T	U	V									

P220 SELECTIONS

COLUMN 14 ENTRY	SHAFT LENGTH RANGE BASED ON MOTOR SHAFT DIAMETER																				
	MOTOR FLANGE SQ.	130 / 150		180		200		220		250		180 / 200 / 220 / 250 / 280		220		250 / 280		320			
	MOTOR SHAFT Ø	≤ Ø 38 mm																			
	MOTOR SHAFT LENGTH RANGE	MIN	MAX	MIN	MAX	MIN	MAX	MIN	MAX	MIN	MAX	MIN	MAX	MIN	MAX	MIN	MAX	MIN	MAX		
COLUMN 14 ENTRY		U		W		X		Y		Z	2		Z		4		6		8		
FLANGE SQUARE																					
COLUMN 15 ENTRY	130	150	180	200	220	250	280	320													
	J	K	H	M	N	Q	R	T													
PILOT DIAMETER																					
COLUMN 16 ENTRY	95	110	114.3	130	180	200	215.9	230	250	300											
	H	J	K	L	M	W	X	Y	Z	7											
BOLT CIRCLE																					
COLUMN 17 ENTRY	130	145	165	184.15	200	215	235	250	265	300	350										
	M	N	P	X	Q	R	Z	7	8	9	2										
BOLT HOLE DIAMETER IN MOTOR FLANGE																					
COLUMN 18 ENTRY	8.4 - 10.3	10.4 - 12.4	12.5 - 15	17 - 20	21 - 24	1/2 - 13	M8														
	D	E	F	G	H	N	R														
MOTOR SHAFT DIAMETER																					
COLUMN 19 ENTRY	Single Reduction	42	45	48	55	60	65														
		T	U	V	W	X	6														
Double Reduction	28.575	32	35	38	42	45	48														
	5	Q	R	S	T	U	V														

1. Use the tables on this page to determine Columns 14-19 of your 20 digit order code.
2. First, choose the appropriate table for the Series P unit size you have selected: P060, P090, P115, P140, P180 and P220.
3. Then select the appropriate codes for Columns 14-19 by matching the dimensions on your servo motor flange to the codes listed in the respective table.
4. If you need assistance, please contact Cone Drive customer service at 888-994-2663.

OUTPUT TORQUE BY GEARBOX SIZE													
RATIOS	UNITS	P-S 060		P-S 090		P-S 115		P-S 140		P-S 180		P-S 220	
		T_{2N}	T_{2ACC}	T_{2N}	T_{2ACC}	T_{2N}	T_{2ACC}	T_{2N}	T_{2ACC}	T_{2N}	T_{2ACC}	T_{2N}	T_{2ACC}
3	Nm	18	35	50	80	120	225	240	470	500	970	1000	1600
4		27	50	75	125	120	330	240	700	750	1400	1500	2300
5		27	50	75	125	180	330	360	700	750	1400	1500	2300
6		27	50	75	125	180	330	360	700	750	1400	1500	2300
7		27	50	75	125	180	330	360	700	750	1400	1500	2300
8		27	50	75	125	180	330	360	700	750	1400	1500	2200
9		18	35	50	80	120	225	240	470	500	970	1000	1900
10		18	35	50	80	120	225	240	470	500	970	1000	1600
15		18	35	50	80	120	225	240	470	500	970	1000	1600
16		27	50	75	125	180	330	360	700	750	1400	1500	2300
20		27	50	75	125	180	330	360	700	750	1400	1500	2300
25		27	50	75	125	180	330	360	700	750	1400	1500	2300
28		27	50	75	125	180	330	360	700	750	1400	1500	2300
30		18	35	50	80	120	225	240	470	500	970	1000	1600
35		27	50	75	125	180	330	360	700	750	1400	1500	2300
40		27	50	75	125	180	330	360	700	750	1400	1500	2300
45		18	35	50	80	120	225	240	470	500	970	1000	1300
50		27	50	75	125	180	330	360	700	750	1400	1500	2300
60		27	50	75	125	180	330	360	700	750	1400	1500	2300
70		27	50	75	125	180	330	360	700	750	1400	1500	2300
80	27	50	75	125	180	330	360	700	750	1400	1500	1800	
90	18	35	50	80	120	225	240	470	500	970	1000	1300	
100	18	35	50	80	120	225	240	470	500	970	1000	1200	

T_{2N} - At nominal input speed, service life is 20,000 hours

T_{2ACC} - The maximum torque during acceleration and deceleration

Series P - S Type General Specifications

ATTRIBUTE	UNITS	GEAR STAGES	SIZE					
			P-S 060	P-S 090	P-S 115	P-S 140	P-S 180	P-S 220
Emergency Stop Torque ¹	Nm	1 & 2	2 x T _{2ACC}					
Degree of Protection ²	—		IP54 (IP65 OPTIONAL)					
Nominal Input Speed ³	rpm		3000	3000	3000	2000	1500	1000
Maximum Input Speed ⁴	rpm		6000	6000	6000	4000	3000	2000
Permitted Housing Temperature	°C	—	90					
Efficiency ⁵	%	1	95	95	95	95	95	97
		2	90	90	90	90	90	92
Weight ⁶	kg	1	1.4	3.7	8	16	36	53
		2	1.6	4.2	8.9	17	37	54
Maximum Torsional Backlash	arc-min	1	≤ 3	≤ 3	≤ 3	≤ 3	≤ 3	≤ 3
		2	≤ 3	≤ 3	≤ 3	≤ 3	≤ 3	≤ 3
Torsional Rigidity ⁷	Nm/ arc-min	1	3	10	31	60	175	400
		2	3	10	31	60	175	400
Noise Level ⁸	dB	1	≤ 66	≤ 67	≤ 71	≤ 67	≤ 67	≤ 61
		2	≤ 66	≤ 67	≤ 71	≤ 67	≤ 67	≤ 61
No Load Running Torque ⁹	Nm	1	0.15	0.35	1.3	1.63	2.68	2.92
		2	0.04	0.06	0.42	0.56	1.39	1.14

1 The maximum torque allowed under a stress situation (Permitted 1,000 times during service life)

2 IP65 (wash-down) is available as an option. Contact Cone Drive for more details

3 The average input speed

4 The maximum intermittent input speed

5 The efficiency at the nominal output torque rating

6 The weight may vary slightly between models

7 This does not include backlash

8 Contact Cone Drive for the testing conditions and environment

9 Torque at no load applied to the input shaft at nominal input speed

PERMITTED RADIAL LOADS

RATIO	UNITS	GEAR STAGES	SIZE							
			Permitted Radial Load ¹							
			P-S 060	P-S 090	P-S 115	P-S 140	P-S 180	P-S 220		
3	N	1	430	810	1300	3200	5600	5800		
4			470	890	1500	3500	6200	6400		
5			510	960	1600	3800	6700	6900		
6			540	1000	1700	4000	7100	7300		
7			570	1100	1800	4200	7400	7700		
8			600	1100	1900	4400	7800	8000		
9			620	1200	1900	4600	8100	8400		
10			640	1200	2000	4700	8400	8700		
15			N	2	740	1400	2300	5400	9600	9900
16					750	1400	2300	5500	9800	10000
20	810	1500			2500	6000	11000	11000		
25	870	1600			2700	6400	11000	12000		
28	910	1700			2800	6700	12000	12000		
30	930	1700			2900	6800	12000	13000		
35	980	1800			3000	7200	13000	13000		
40	1000	1900			3200	7500	13000	14000		
45	1100	2000			3300	7800	14000	14000		
50	1100	2100			3400	8100	14000	15000		
60	1200	2200	3600	8600	15000	15000				
70	1200	2300	3800	9100	15000	15000				
80	1200	2400	4000	9100	15000	15000				
90	1200	2400	4200	9100	15000	15000				
100	1200	2400	4300	9100	15000	15000				

¹ At this load and nominal input speed, service life will be 20,000 hours.
(The radial load applied to the output side shaft center)

PERMITTED AXIAL LOADS

RATIO	UNITS	GEAR STAGES	SIZE								
			Permitted Axial Load ²								
			P-S 042	P-S 060	P-S 090	P-S 115	P-S 140	P-S 180	P-S 220		
3	N	1	270	310	930	1500	2400	4300	6400		
4			300	360	1100	1700	2700	4900	7200		
5			330	390	1200	1900	3000	5400	7900		
6			360	430	1300	2000	3300	5800	8600		
7			380	460	1300	2100	3500	6300	9200		
8			410	480	1400	2300	3700	6600	9700		
9			430	510	1500	2400	3900	7000	10000		
10			450	530	1600	2500	4100	7300	11000		
15			N	2	540	630	1900	3000	4900	8700	13000
16					550	650	1900	3100	5000	8900	13000
20	610	720			2100	3400	5500	9900	14000		
25	640	790			2200	3700	6100	11000	14000		
28	640	830			2200	3900	6400	11000	14000		
30	640	860			2200	3900	6600	12000	14000		
35	640	920			2200	3900	7000	13000	14000		
40	640	970			2200	3900	7500	13000	14000		
45	640	1000			2200	3900	7900	14000	14000		
50	640	1100			2200	3900	8200	14000	14000		
60	640	1100	2200	3900	8200	14000	14000				
70	640	1100	2200	3900	8200	14000	14000				
80	640	1100	2200	3900	8200	14000	14000				
90	640	1100	2200	3900	8200	14000	14000				
100	640	1100	2200	3900	8200	14000	14000				

² At this load and nominal input speed, service life will be 20,000 hours.
(The axial load applied to the output side bearing)

MAXIMUM RADIAL LOADS

RATIO	UNITS	GEAR STAGES	SIZE							
			Maximum Radial Load ¹							
			P-S 060	P-S 090	P-S 115	P-S 140	P-S 180	P-S 220		
3	N	1	1200	2400	4300	9100	15000	15000		
4			1200	2400	4300	9100	15000	15000		
5			1200	2400	4300	9100	15000	15000		
6			1200	2400	4300	9100	15000	15000		
7			1200	2400	4300	9100	15000	15000		
8			1200	2400	4300	9100	15000	15000		
9			1200	2400	4300	9100	15000	15000		
10			1200	2400	4300	9100	15000	15000		
15			N	2	1200	2400	4300	9100	15000	15000
16					1200	2400	4300	9100	15000	15000
20	1200	2400			4300	9100	15000	15000		
25	1200	2400			4300	9100	15000	15000		
28	1200	2400			4300	9100	15000	15000		
30	1200	2400			4300	9100	15000	15000		
35	1200	2400			4300	9100	15000	15000		
40	1200	2400			4300	9100	15000	15000		
45	1200	2400			4300	9100	15000	15000		
50	1200	2400			4300	9100	15000	15000		
60	1200	2400	4300	9100	15000	15000				
70	1200	2400	4300	9100	15000	15000				
80	1200	2400	4300	9100	15000	15000				
90	1200	2400	4300	9100	15000	15000				
100	1200	2400	4300	9100	15000	15000				

¹ The maximum radial load that the gearbox can accept at the center of the output shaft

MAXIMUM AXIAL LOADS

RATIO	UNITS	GEAR STAGES	SIZE								
			Maximum Axial Load ²								
			P-S 042	P-S 060	P-S 090	P-S 115	P-S 140	P-S 180	P-S 220		
3	N	1	640	1100	2200	3900	8200	14000	14000		
4			640	1100	2200	3900	8200	14000	14000		
5			640	1100	2200	3900	8200	14000	14000		
6			640	1100	2200	3900	8200	14000	14000		
7			640	1100	2200	3900	8200	14000	14000		
8			640	1100	2200	3900	8200	14000	14000		
9			640	1100	2200	3900	8200	14000	14000		
10			640	1100	2200	3900	8200	14000	14000		
15			N	2	640	1100	2200	3900	8200	14000	14000
16					640	1100	2200	3900	8200	14000	14000
20	640	1100			2200	3900	8200	14000	14000		
25	640	1100			2200	3900	8200	14000	14000		
28	640	1100			2200	3900	8200	14000	14000		
30	640	1100			2200	3900	8200	14000	14000		
35	640	1100			2200	3900	8200	14000	14000		
40	640	1100			2200	3900	8200	14000	14000		
45	640	1100			2200	3900	8200	14000	14000		
50	640	1100			2200	3900	8200	14000	14000		
60	640	1100	2200	3900	8200	14000	14000				
70	640	1100	2200	3900	8200	14000	14000				
80	640	1100	2200	3900	8200	14000	14000				
90	640	1100	2200	3900	8200	14000	14000				
100	640	1100	2200	3900	8200	14000	14000				

² The maximum axial load that the gearbox can accept

Series P - S Type Inertia Values

RATIO	UNITS	SIZE											
		P-S 060			P-S 090				P-S 115				
Motor Shaft Diameter		≤Ø 8	≤Ø 14	≤Ø 19	≤Ø 8	≤Ø 14	≤Ø 19	≤Ø 28	≤Ø 8	≤Ø 14	≤Ø 19	≤Ø 28	≤Ø 38
3	kgcm ²	0.140	0.25	0.53	-	0.72	1.10	2.90	-	-	3.20	5.10	12.00
4		0.095	0.21	0.48	-	0.50	0.90	2.70	-	-	2.00	3.70	10.00
5		0.077	0.19	0.46	-	0.41	0.80	2.60	-	-	1.40	3.10	9.50
6		0.068	0.18	0.46	-	0.36	0.75	2.50	-	-	1.20	2.90	9.30
7		0.062	0.17	0.45	-	0.33	0.73	2.50	-	-	1.00	2.80	9.10
8		0.059	0.17	0.45	-	0.31	0.71	2.50	-	-	0.92	2.70	9.00
9		0.057	0.17	0.44	-	0.30	0.70	2.50	-	-	0.86	2.60	8.90
10		0.056	0.17	0.44	-	0.30	0.70	2.50	-	-	0.83	2.60	8.90
15		0.064	0.18	0.45	0.20	0.36	0.75	2.50	-	0.77	1.20	2.90	9.20
16		0.070	0.18	0.46	0.25	0.41	0.79	2.50	-	0.98	1.40	3.10	9.40
20		0.062	0.17	0.45	0.19	0.35	0.74	2.50	-	0.72	1.10	2.80	9.10
25		0.061	0.17	0.45	0.19	0.35	0.74	2.50	-	0.70	1.10	2.80	9.10
28		0.068	0.18	0.46	0.24	0.40	0.78	2.50	-	0.92	1.30	3.00	9.30
30		0.051	0.16	0.44	0.12	0.28	0.67	2.40	-	0.38	0.78	2.50	8.80
35		0.061	0.17	0.45	0.18	0.35	0.73	2.50	-	0.68	1.10	2.80	9.10
40		0.051	0.16	0.44	0.11	0.28	0.67	2.40	-	0.37	0.77	2.50	8.80
45		0.061	0.17	0.45	0.18	0.34	0.73	2.50	-	0.68	1.10	2.80	9.10
50		0.051	0.16	0.44	0.11	0.27	0.67	2.40	0.19	0.36	0.76	2.50	8.80
60		0.051	0.16	0.44	0.11	0.27	0.67	2.40	0.19	0.36	0.76	2.50	8.80
70		0.051	0.16	0.44	0.11	0.27	0.67	2.40	0.19	0.36	0.76	2.50	8.80
80	0.051	0.16	0.44	0.11	0.27	0.67	2.40	0.19	0.36	0.76	2.50	8.80	
90	0.051	0.16	0.44	0.11	0.27	0.67	2.40	0.19	0.36	0.76	2.50	8.80	
100	0.051	0.16	0.44	0.11	0.27	0.67	2.40	0.19	0.36	0.76	2.50	8.80	

RATIO	UNITS	SIZE													
		P-S 140					P-S 180					P-S 220			
Motor Shaft Diameter		≤Ø 14	≤Ø 19	≤Ø 28	≤Ø 38	≤Ø 48	≤Ø 19	≤Ø 28	≤Ø 38	≤Ø 48	≤Ø 65	≤Ø 28	≤Ø 38	≤Ø 48	≤Ø 65
3	kgcm ²	-	-	12	18	35	-	-	43	57	110	-	-	110	160
4		-	-	7.3	14	29	-	-	26	41	85	-	-	54	98
5		-	-	5.3	12	27	-	-	19	34	78	-	-	42	85
6		-	-	4.3	11	26	-	-	15	31	75	-	-	35	79
7		-	-	3.9	10	25	-	-	14	29	73	-	-	33	76
8		-	-	3.5	9.9	25	-	-	13	28	72	-	-	30	74
9		-	-	3.3	9.7	25	-	-	12	27	71	-	-	29	73
10		-	-	3.2	9.6	25	-	-	12	27	71	-	-	28	72
15		-	2.6	4.4	11	26	-	8.8	15	30	0	-	20	34	-
16		-	3.5	5.3	12	27	-	11	18	33	0	-	24	39	-
20		-	2.4	4.2	10	25	-	8.1	14	29	0	-	19	33	-
25		-	2.4	4.1	10	25	-	7.9	14	29	0	-	18	33	-
28		-	3.3	5.1	11	26	-	11	17	32	0	-	23	37	-
30		-	1.1	2.9	9.2	24	-	4	10	25	0	-	12	26	-
35		-	2.3	4.1	10	25	-	7.6	14	29	0	-	18	32	-
40		-	1.1	2.8	9.1	24	-	3.9	10	25	0	-	12	26	-
45		-	2.3	4	10	25	-	7.6	14	29	0	-	18	32	-
50		0.65	1.1	2.8	9.1	24	1.9	3.8	10	25	0	4.7	12	26	-
60		0.64	1.1	2.8	9.1	24	1.9	3.8	10	25	0	4.7	11	26	-
70		0.64	1.1	2.8	9.1	24	1.8	3.8	10	25	0	4.6	11	26	-
80	0.63	1.1	2.8	9.1	24	1.8	3.7	10	25	0	4.6	11	26	-	
90	0.63	1.1	2.8	9.1	24	1.8	3.7	10	25	0	4.6	11	26	-	
100	0.63	1.1	2.8	9.1	24	1.8	3.7	10	25	0	4.6	11	26	-	

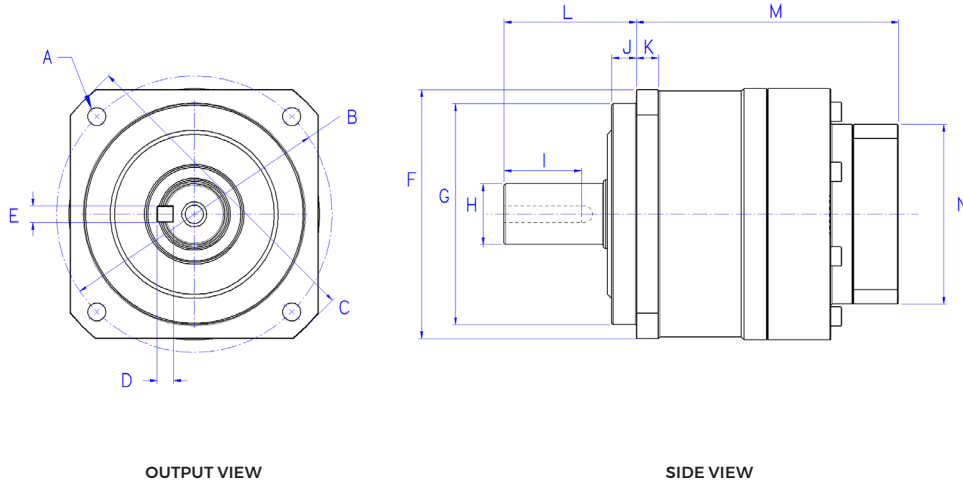

MODEL	UNITS	GEAR STAGES	INPUT BORE SIZE	M	N	A	B	C	D	E	F (g6)	G (g6)	H	I	J	K	L
				BODY LENGTH ¹	INPUT FLANGE SQUARE	MOUNTING HOLE	BOLT CIRCLE	FLANGE DIA-METER	KEY HEIGHT	KEY WIDTH	OUTPUT FLANGE SQUARE	PILOT DIAMETER	SHAFT DIAMETER	KEY LENGTH	PILOT DEPTH	FLANGE THICK-NESS	OUTPUT SHAFT LENGTH FROM FLANGE
P-S 060		1	≤ Ø 8	75	52	5.5	70	80	5	5	60	50	16	22	6	6	37
			≤ Ø 14	78	65												
		≤ Ø 19	93	80													
		≤ Ø 8	94	52													
P-S 090		1	≤ Ø 8	94	52	6.6	100	115	6	6	90	80	22	28	9	8	48
			≤ Ø 14	99	65												
		≤ Ø 19	114	80													
		≤ Ø 14	117	65													
P-S 115	mm	1	≤ Ø 14	117	65	9	130	148	8	10	115	110	32	45	4	10	65
			≤ Ø 19	122	80												
		≤ Ø 28	139	130													
		≤ Ø 38	160	180													
P-S 140		1	≤ Ø 14	139.5	65	11	165	185	8	12	140	130	40	65	12	12	97
			≤ Ø 19	149.5	80												
		≤ Ø 28	166.5	130													
		≤ Ø 38	201.5	180													
P-S 180		1	≤ Ø 28	152	130	13.5	215	240	10	16	180	160	55	65	20	15	105
			≤ Ø 38	167	180												
		≤ Ø 48	208	180													
		≤ Ø 19	169.5	80													
P-S 220		1	≤ Ø 28	186.5	130	17	250	290	12	20	220	180	75	85	30	20	138
			≤ Ø 38	201.5	180												
		≤ Ø 48	211	130													
		≤ Ø 38	226	180													
P-S 220		2	≤ Ø 48	262	180	17	250	290	12	20	220	180	75	85	30	20	138
			≤ Ø 48	229.5	180												
P-S 220		1	≤ Ø 48	229.5	180	17	250	290	12	20	220	180	75	85	30	20	138
			≤ Ø 65	233.5	250												
P-S 220		2	≤ Ø 38	228.5	180	17	250	290	12	20	220	180	75	85	30	20	138
			≤ Ø 48	264.5	180												

¹ Length will vary depending on motor

Inspection and Preparation

- A. Upon delivery of the gearbox, confirm that you received the exact model specified on your purchase order.
- B. Inspect for shipping damage.
- C. Remove the protective covering from the output shaft.
- D. Clean and degrease the motor mounting surface and shaft, as well as the gearbox mounting surface, input hub bore, and shaft bushing (if included). This cleaning is very important for the shaft and bushing, to prevent slip during motion.

Motor Mounting

- A. Remove the access hole plug, allowing access to the motor shaft clamp.
- B. Carefully align the input bore shaft bushing (if included) so that the gap in the bushing aligns with the gap in the input hub. It is also recommended that the motor shaft keyway (if present) aligns with the gap in the input hub clamp.
- C. Rotate the gearbox input hub so that the clamp bolt is aligned with the access hole. Loosen the clamp bolt.
- D. Remove the motor key (if supplied), as it is not required for proper installation and operation.
- E. Carefully slide the motor shaft into the gearbox input hub with motor shaft keyway (if present) aligned with gearbox input shaft clamp gap. Install the four motor flange bolts in a cross-wise pattern, to ensure proper alignment of motor to gearbox, tightening appropriately.
- F. Tighten the gearbox input shaft clamp bolt to the proper torque using a torque wrench (see table).
- G. Re-install the access hole plug into the motor adapter plate. Assembly is complete.

Safety Precautions

- A. Avoid use in wet or corrosive areas, unless the gearbox is specified for these environments.
- B. Ambient temperature in the area of the gearbox must be in the range of 0° to -40°C.
- C. The gearbox has been lubricated for its lifetime with appropriate grease and can be operated immediately. No re-lubrication is required.
- D. The gearbox must be firmly attached to a vibration-free frame or fixture.
- E. Items mounted to the output shaft must be installed carefully to avoid damage to the shaft, bearings, and seal.
- F. Ensure that the motor speed does not exceed the maximum RPM specified for the gearbox. Avoid excessive loads.
- G. Make sure driven machine is clear of all obstructions and all safety guards and covers are in place. At initial operation, check the direction of shaft rotation, then apply the load gradually.
- H. The gearbox is not designed to be disassembled.

IP 65 Versions

For IP65 version of the gearbox, be sure to seal between the gearbox and motor interface with a sealant to ensure an IP65 rating of the gearbox / motor assembly. Also apply sealant to the shaft clamp access hole plug.

CLAMP BOLT SIZE	TORQUE TIGHTENING	
	(Nm)	(in lbs)
M3	1.9	16.8
M4	4.3	38.1
M5	8.7	77
M6	15	133
M8	36	318
M10	71	628
M12	125	1106



GLOBAL LOCATIONS

NORTH AMERICA | EUROPE | ASIA

