

Powerful, clean solutions with a stainless reputation.

Industry-leading features and unparalleled support make Cone Drive's stainless reducer suitable for the most sterile manufacturing environments. Cone Drive Stainless Steel is equipped to withstand the most caustic washdown operations.

PACKAGING | FOOD & BEVERAGE | PHARMACEUTICAL | MEAT & DAIRY

MADE IN
USA

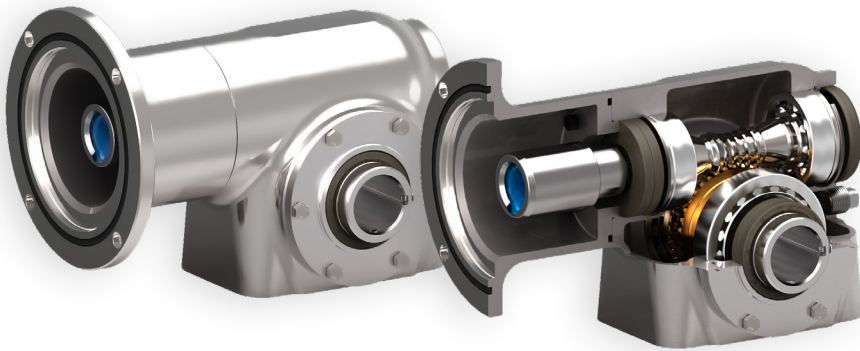

NEMA Product Support:

- Industry-leading lead times
- Configuration & rating tools for 3D models and tested & verified ratings
- 5-year warranty
- Modifications & customizations
- Immediate engineering and sales support

NEMA Double Reduction

NEMA Single Reduction



CONFIGURE & DOWNLOAD YOUR MODEL AT [ConeTools.com](https://www.conedrive.com/ConeTools.com)

S P E C I F I C A T I O N S

PRODUCT FEATURES



- Lightweight, symmetrical, contoured housing for easy cleaning to maintain bacteria free environments
- Reducer and custom options available with standard quill & non-fretting bushing
- Stainless steel (316) housing and solid, hollow, or shrink disk output options in inch or metric
- Feet, flanges, or direct mounting for universal positioning
- Dual input bearing and true double enveloping gearing for superior rigidity and torque density
- Lifetime food-grade lubrication, suited for temperatures from -22° to 200° F (-30° to 93°C)
- Double input & output seals with material upgrades available, and o-ring equipped adaptation
- IP69K, A3 and NSF rated, tested, and approved hygienic design

PRODUCT SPECIFICATIONS

- Sizes Available:** 1.54, 1.75, 1.97, 2.38, 3.00 in (39, 44, 50, 60, 76 mm)
- Ratios:** 5:1 to 600:1, custom
- Backlash Range:** 4 to 24 arcmin (.07 to 0.40°)
- Input Speed:** <1750 RPM
- Input Power:** <14 HP (10 kW)
- Output Torque:** <6,200 in-lbs. (700 Nm)
- Efficiency:** <92%



 Cone Drive Operations, Inc.
240 East 12th Street
Traverse City, MI 49684, USA

 +1.888.994.2663
 orders@conedrive.com
 [conedrive.com](https://www.conedrive.com)

Powerful, clean solutions with a stainless reputation.

Industry-leading features and unparalleled support make Cone Drive's stainless reducer suitable for the most sterile manufacturing environments. Cone Drive Stainless Steel is equipped to withstand the most caustic washdown operations.

PACKAGING | FOOD & BEVERAGE | PHARMACEUTICAL | MEAT & DAIRY

MADE IN
USA

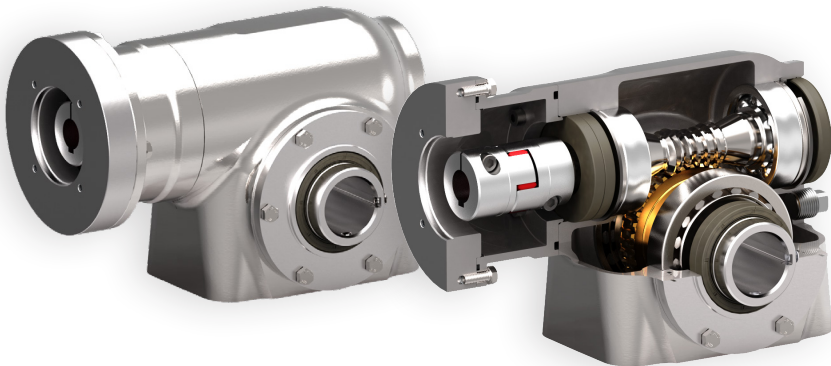

Servo Product Support:

- Industry-leading lead times
- Configuration & rating tools for 3D models and tested & verified ratings
- 5-year warranty
- Modifications & customizations
- Immediate engineering and sales support

SERVO Single Reduction

 [CONFIGURE & DOWNLOAD YOUR MODEL AT ConeTools.com](#)

S P E C I F I C A T I O N S

PRODUCT FEATURES

- Lightweight, symmetrical, contoured housing for easy cleaning to maintain bacteria free environments
- Reducer and custom options available with zero-backlash coupling connections
- Stainless steel (316) housing and solid, hollow, or shrink disk output options in inch or metric
- Feet, flanges, or direct mounting for universal positioning
- Dual input bearing and true double enveloping gearing for superior rigidity and torque density
- Lifetime food-grade lubrication, suited for temperatures from -22° to 200° F (-30° to 93°C)
- Double input & output seals with material upgrades available, and o-ring equipped adaptation
- IP69K, A3 and NSF rated, tested, and approved hygienic design

PRODUCT SPECIFICATIONS

Sizes Available: 1.54, 1.75, 1.97, 2.38, 3.00 in
(39, 44, 50, 60, 76 mm)

Ratios: 5:1 to 60:1, custom

Backlash Range: 4 to 24 arcmin (.07 to 0.40°)

Input Speed: <3000 RPM



Efficiency: <92%

T_{accel-in} : <900 in-lbs. (100 Nm)

T_{accel-out} : <6400 in-lbs. (725 Nm)



 Cone Drive Operations, Inc.
240 East 12th Street
Traverse City, MI 49684, USA

 +1.888.994.2663
 orders@conedrive.com
 conedrive.com