

LUBRICATION, INSTALLATION, OPERATION, & MAINTENANCE INSTRUCTIONS FOR MODEL HP-A CONE DRIVE SPEED REDUCERS

Cone Drive double-enveloping worm gear speed reducers are used throughout industry to provide smooth and quiet speed reduction. When properly selected, applied and maintained, they will provide optimum performance.

IMPORTANT: In any applications of Cone Drive Products where breakage, damage, disconnection, any other malfunction of any drive train component, or excessive wear could result in personal injury or property damage, a failsafe device capable of stopping and holding the load in the event of such an occurrence must be incorporated after the drive train.

THE FOLLOWING INFORMATION IS FOR YOUR PROTECTION. PLEASE READ CAREFULLY.

1. Do not attempt to install or operate this reducer until these instructions are read and thoroughly understood. If you have any questions, please contact Cone Drive.
2. The horsepower or output torque capacity of this reducer and the service factor (maximum allowable operating cycle) are stamped on the reducer nameplate. These values are not to be exceeded as overloading can result in reducer failure. Exceeding the rating and duty cycle will void the warranty. Please contact Cone Drive with any questions regarding rating and service factors.
3. Each reducer is specifically arranged to operate at the input speed specified on the nameplate. If the input speed is not specified by the customer, it is set up for 1750 RPM and service factor 1.0. Do not operate the reducer at speeds or under service other than specified on the nameplate without contacting Cone Drive for specific instructions on oil level location and bearing settings
4. Do not alter the reducer without approval from Cone Drive.
5. This reducer has moving mechanical components and connected electrical devices, operating under high voltage to achieve its intended purpose. Operation and repair should only be done by qualified personnel.
6. Before servicing a speed reducer, the main electrical disconnect must be moved to and locked in the off position. The person performing the work should post on that disconnect a warning to others not to turn on the power.
7. It is normal for the reducer to operate at a housing temperature of up to 200°F. To prevent burns, proper guards or shields should be provided by the purchaser or user to prevent personnel from touching the reducer.
8. Cone Drive products are furnished without guard covers. It is the responsibility of the purchaser or user to provide guards for all exposed shafting, couplings, sprockets, sheaves, belts, chains, clutches, and any other moving parts in accordance with current local, state, and federal requirements.
9. Failure to follow the instructions contained in this bulletin may result in unit failure, property damage or personal injury.

FINISH COAT PAINTING

Cone Drive speed reducers are furnished with a prime coat of paint on exterior housing surfaces. The reducer should be painted with a finish coat to protect the housing exterior, particularly if subjected to outdoor service, periodic wash down or harsh environments. Mask all shafts, oil seals, tags, name plates, oil level stickers, breathers, gauges etc. before painting. (Painting seal lips can result in oil leakage.)

INSTALLATION

IMPORTANT: Unless otherwise specified on the reducer or in accompanying documentation, all Cone Drive speed reducers are shipped without oil and must be filled to the oil level gage or plug with the proper oil before start-up. See the following section on lubrication

- The speed reducer must be securely mounted to a rigid foundation or base plate. If necessary, shim under the reducer feet to provide a flat mounting surface.
- Bolt the reducer to the foundation or mounting base using the largest diameter bolt that will fit through the foot holes of the reducer. Be sure to use a bolt in all available threaded mounting holes. Mount the reducer using bolts to SAE Grade 8 or ISO Grade 8.8 minimum.
- Angular and parallel alignment of the output shaft to the rotating machine interface is critical to prevent premature output seal leaks. Recommended angular alignment to be within $\frac{1}{2}$ degree and parallel alignment to be within $\pm .005$ " unless otherwise specified by coupling manufacturer.
- Sprockets and sheaves should be mounted as close to the reducer as possible and "V" belts and chains adjusted to the proper tension to keep bearing loading and shaft deflection to a minimum. Too much tension in belts and improper location of sheaves and sprockets will lead to excessive chain pull, bearing wear and shaft deflection. For specific information on chain pull capacity, shaft stress and bearing life please contact Cone Drive.
- Note:** Exposed metal parts are coated with commercial rust inhibitor. This rust inhibitor must be removed prior to installation. Failure to do so may result in difficulty in assembling close tolerance mating components.
- Before starting motor review motor rotation, reducer rotation and required direction of driven machine to ensure that the motor is wired for proper direction of rotation. In many instances a machine must run in one direction and failure to wire the motor properly can result in damage to the driven machine.

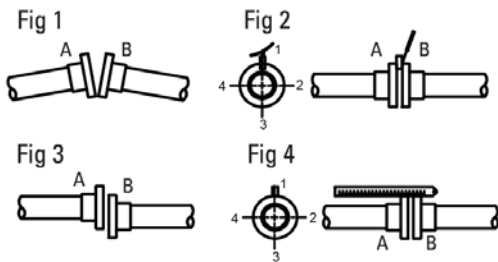

Angular Errors

- Take up end float pushing in shaft ends
- Using thickness and feeler gauges take readings in positions 1, 2, 3, and 4 (Fig 2).
- Adjust unit by shimming under feet

Parallel Errors

- Place straight edge across coupling halves at points 1, 2, 3, and 4 (Fig 4). If coupling diameters are not equal, use feeler gauge equal to half the difference in diameters.
- If error is in the vertical plane, adjust the height of the unit. If error is in the horizontal plane, move unit transversely

- Couplings, sheaves and sprockets should be mounted on the reducer shafts carefully. Do not pound or hammer them onto the shafts as this will damage bearings and oil seals.

- IMPORTANT:** Fill unit to proper level with recommended oil. Grease all fittings with recommended grease (see section on lubrication). In the case of double or triple reduction reducers, be sure to fill each reduction stage to the proper oil level. **Note: Some reducers may have been factory filled. Read all tags**
- Note:** All reducers are built for one mounting position, i.e.; floor mounted or wall mounted with worm vertical up or ceiling mounted, etc. If the reducer is to be mounted in any position other than the position for which it was furnished, contact Cone Drive for information on relocating oil level, grease packing bearings, etc., before start-up. If a reducer is operated in a mounting position other than the position for which it was assembled, reducer failure may occur from improper oil level or grease fitting location resulting in lack of lubrication to the gearset and bearings.

START-UP

1. After the reducer has been properly mounted, aligned and lubricated, it is ready for startup.
2. Make sure driven machine is clear of all obstructions and all safety guards and covers are in place, according to appropriate local, state, and federal requirements. If possible, turn motor shaft by hand to confirm drive system is operating freely and in correct direction of rotation.
3. Jog motor to confirm proper rotation.
4. Operate reducer with minimum load for approximately 15 minutes (in both directions if applicable) to seat gears, bearings, and oil seals.

OPERATION

1. All reducers require a few hours of “run-in” under load to achieve optimum efficiency. During this initial run-in the reducer will probably run warmer than normal and draw more current than after the run-in period. Reducers operating at a very low load or speed will take much longer to run-in and even if operated continuously at low load or speed may never achieve the efficiency that they would if operated at or near their catalog rating.
2. **IMPORTANT:** Normal reducer operating temperature measured at the oil sump area of the housing should not exceed 200°F. Excessive oil sump temperature is indicative of overloading, misalignment, or improper or marginal lubrication. Continuous operation of the reducer with the oil sump temperature above 200°F will result in premature breakdown of the oil and reduce the useful life of the reducer or result in premature failure.

MAINTENANCE

1. The reducer oil levels should be checked regularly and the recommended oil added as required to maintain the proper oil level.
2. Grease fittings and internal retainers are furnished when required. They should be greased with a high quality lithium base NLGI #2 or NLGI #3 bearing grease at normal maintenance intervals depending on the duty cycle of the reducer.
3. The reducer, particularly finned areas and fan covers, should be kept clean to allow maximum heat dissipation.
4. All reducers and foundation bolts should be checked for tightness after three (3) months of service and annually thereafter.
5. If a reducer is to be repaired, contact Cone Drive for detailed instructions, drawings, parts lists, etc. If it is necessary, field service is available.
6. If a reducer is to be returned, contact Cone Drive for instructions and a return material authorization (CASE) number.

OIL CHANGE

If an approved synthetic lubricant is used, it should be changed after 5000 hours of operation or once per year, whichever occurs first. See Cone Drive's *Approved List of Lubricants* (23169) for recommended lubricants. These change intervals are recommended for units operating under favorable conditions. Where operating conditions are severe, such a rapid rise and fall in temperature of the gear case with accompanied sweating of the inside walls and resulting formation of sludge, or where operation is in moist or dusty atmospheres, or in the presence of chemical fumes or extended running at sump temperatures in excess of 180°F, it may be necessary to change the oil at intervals of one to three months. It is recommended a sampling program be established with your lubricant manufacturer where reducers are exposed to the severe operating conditions, mentioned above.

If switching to a different type of lubricant, care should be taken to thoroughly flush out all of the old lubricant before filling with new lubricant. Mixing of different lubricants can result in degraded performance or failure.

STORAGE RECOMMENDATIONS FOR CONE DRIVE SPEED REDUCERS

If a reducer is to be stored or shut down for more than 60 days, it should be protected from water condensation and corrosion as follows:

Any enclosed system of gearing is subject to water condensation on the inside of the reducer caused by fluctuating ambient temperatures. This condensation can cause severe rusting of the worm and bearings which could lead to premature failure of the reducer. However, this condition can be prevented by following the recommendations outlined for various storage conditions. If the reducer is furnished with a motor, follow the motor manufacturer's recommendations for motor preservation.

1. **Standard Shipping Procedure - Protection for Maximum Storage Duration of 60 Days.** Cone Drive speed reducers are treated inside using a rust inhibitor, the exterior is painted with one coat of primer and all exposed shafting coated with a rust preventative prior to shipment. This procedure is intended to protect the reducers during shipment and short term inside storage for a maximum period of sixty (60) days after shipment.
2. **Long Term Storage (Indoors) for Periods up to One Year.**
 - 2a. Fill the reducer completely full with one of the lubricants shown on Cone Drive's Approved List of Lubricants (23169). A copy of the lubricant list is shipped with each unit.
 - 2b. Rotate the worm shaft and gear shaft at least every 60 days to keep the seals from sticking to the shafts.

2c. If it is not practical to rotate the worm shaft periodically, it is recommended to purchase a spare set of oil seals to have on hand in case of seal leakage at start-up.

2d. Before putting the reducer into service, lower the oil in the reducer to the proper operating level

3. **Long Term Storage (Outdoors) for Periods Up to One Year.** Proceed as in (2) with the following additions:
 - 3a. After filling the unit with oil, plug the breather with a pipe plug and wire the breather to the unit.
 - 3b. Paint the outside of the unit with a finish coat of paint. (Reducer from the factory is prime coated only.)
 - 3c. Coat all exposed shafting with a long term rust preventative.
4. **Extended Storage Periods Exceeding One Year.** Immediately after receipt of the reducer:
 - 4a. Apply finish paint to the exterior of the unit, excluding shafts and mounting points
 - 4b. Coat all exposed unpainted surfaces with a long term rust preventative
 - 4c. Place the unit in a vapor corrosion inhibitor (VCI) bag and seal the bag air tight.
 - 4d. Crate the unit and cover the crate to keep out water.
 - 4e. Purchase a spare set of oil seals to have on hand in case of leakage at start-up.

LUBRICATION

Lubrication is very important for successful operation of Cone Drive gearsets and speed reducers. Inadequate lubrication can result in increased power consumption, added maintenance and gearset failure. Please review the following recommendations and the "Approved List of Lubricants" shipped with all Cone Drive gearsets and speed reducers. Use of other lubricants can result in gearset failure which will not be covered under warranty. See reducer's nameplate for the recommended lubricant.

TYPE OF OIL

Rated performance of Cone Drive products is based on synthetic lubricants.

AMBIENT TEMPERATURE

The oils shown in Cone Drives *Approved List of Lubricants* (23169) are for use in an ambient temperature range of approximately 15°F to 125°F with the low end of the range depending on the pour point of the specific oil used. If the ambient temperature will be below or above this range please contact Cone Drive for specific recommendations on proper lubricant as well as proper oil seal and shim materials.

SLUDGE

It is necessary that the oil be clean and free from sludge at all times to obtain long life from a gear unit. Sludge in gear units may be caused by excessive heat, from dust and dirt and other contaminants and by the presence of moisture or chemical fumes. Therefore, every precaution should be taken to prevent water and foreign particles from entering the gear case.

OIL LEVEL

Cone Drive reducers are furnished with a bronze colored hex head pipe plug to indicate oil level. An oil level tag is affixed to the unit near the oil level indicator. Oil level should always be checked with the unit stopped. Estimated oil capacities for standard reducers are listed in *Oil Capacity for Model HP-A* (25173) and are shipped with all Cone Drive reducers.

DOUBLE AND TRIPLE REDUCTION REDUCERS

These units utilize separate housings and are furnished with separate oil sumps. It is important that all sumps are filled to the proper oil level.

EXTREME PRESSURE OR ANTI-SCUFFING LUBRICANTS

Lubricants rated extreme pressure (EP), anti-scuffing (AS), or having sulphur-phosphorus additives are not acceptable and should not be used in Cone Drive speed reducers or worm gearing.

OIL SEAL REPLACEMENT INSTRUCTIONS

IF THE INPUT OIL SEALS REQUIRE REPLACEMENT

1. Uninstall reducer
2. Drain lubricant from reducer
3. Remove exterior components (motor, adapter plate, coupling etc.)
4. Unbolt motor adapter bell with the seal from the housing
 - o Be sure to not damage the shims located between the motor adapter bell and the housing. The shims are necessary for proper spacing of the input shaft bearings
5. In the case of units without a motor adapter bell, the input carrier does not need to be unbolted from the housing
6. Remove seal(s)
 - o Be careful not to scratch housing or shaft, or create fragments that could enter reducer as damage or penetration could result in potential leaks and failure
7. Install replacement seals
 - o Press-up seals evenly and carefully to avoid damage to the seal and reducer components
8. Re-attach the motor adapter with the new seal to the housing, ensuring the shims are between the motor adapter and housing
9. Flush and refill the reducer with an approved lubricant, see *Approved List of Lubricants* (23169)
10. Reattach coupling and any exterior components
11. Reinstall reducer

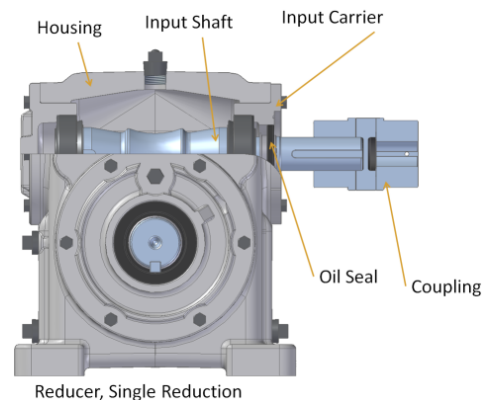
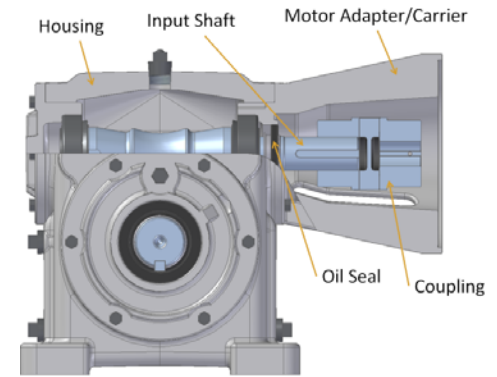

IF THE OUTPUT OIL SEALS REQUIRE REPLACEMENT

1. Uninstall reducer
2. Drain lubricant
3. Remove exterior components (output flange)
4. Remove seal(s)
 - o Be careful not to scratch housing or shaft, or create fragments that could enter reducer as damage or penetration could result in potential leaks and failure
5. Install replacement seals
 - o Press-up seals evenly and carefully to avoid damage to the seal and reducer components
6. Flush and refill the reducer with an approved lubricant (See table 1 and 2)
7. Reattach exterior components
8. Reinstall reducer

